



# **MARKSCHEME**

**November 2012**

**DESIGN TECHNOLOGY**

**Higher Level**

**Paper 3**

*This markscheme is **confidential** and for the exclusive use of examiners in this examination session.*

*It is the property of the International Baccalaureate and must **not** be reproduced or distributed to any other person without the authorization of IB Assessment Centre.*

## Subject Details: Design Technology HL Paper 3 Markscheme

### Mark Allocation

Candidates are required to answer questions from **ONE** of the Options [**1 × 40 marks**].

Maximum total = [**40 marks**]

1. A markscheme often has more marking points than the total allows. This is intentional. Do **not** award more than the maximum marks allowed for part of a question.
2. Each marking point has a separate line and the end is shown by means of a semicolon (;).
3. An alternative answer or wording is indicated in the markscheme by a slash (/). Either wording can be accepted.
4. Words in brackets ( ) in the markscheme are not necessary to gain the mark.
5. Words that are underlined are essential for the mark.
6. The order of marking points does not have to be as in the markscheme, unless stated otherwise.
7. If the candidate's answer has the same "meaning" or can be clearly interpreted as being of equivalent significance, detail and validity as that in the markscheme then award the mark. Where this point is considered to be particularly relevant in a question it is emphasized by **OWTTE** (or words to that effect).
8. Remember that many candidates are writing in a second language. Effective communication is more important than grammatical accuracy.
9. Occasionally, a part of a question may require an answer that is required for subsequent marking points. If an error is made in the first marking point then it should be penalized. However, if the incorrect answer is used correctly in subsequent marking points then **follow through** marks should be awarded. When marking, indicate this by adding **ECF** (error carried forward) on the script.
10. Only consider units at the end of a calculation. Unless directed otherwise in the markscheme, unit errors should only be penalized once in the paper. Indicate this by writing **-1(U)** at the first point it occurs and **U** on the cover page.
11. Do not penalize candidates for errors in units or significant figures, unless it is specifically referred to in the markscheme.

**Option A — Food science and technology**

- A1.** (a) *Award [1] for stating one benefit of primary processing of wheat to produce white flour.*  
removal of microorganisms and small insects;  
enhanced shelf life;  
better storage properties; **[1 max]**
- (b) *Award [1] for identifying one effect of excess carbohydrate intake and [1] for a brief explanation [2 max].*  
excess carbohydrate converted to fat;  
fat stored subcutaneously and around organs leads to overweight and obesity; **[2 max]**
- (c) *Award [1] for each of three distinct correct points in a discussion of how health awareness affects food choice in relation to fibre intake [3 max].*  
low fibre intake can lead to a range of problems (*e.g.* increased gut transit times, raised cholesterol levels, haemorrhoids, colonic cancer);  
health awareness would make people eat higher fibre diet;  
selection of higher fibre foods, *e.g.* breads made from wholewheat not white flour; **[3 max]**
- A2.** (a) *Award [1] for stating one concern relating to the genetic modification of food crops.*  
are they safe for human consumption;  
will they cause allergies and other adverse reactions;  
what are the impacts on the environment;  
will the genes be transferred to other organisms; **[1 max]**
- (b) *Award [1] for outlining one reason why public acceptance of a genetically-modified foods is important and [1] for a brief explanation [2 max].*  
need to create a market;  
without a market there is no point making the product; **[2 max]**

- A3.** (a) *Award [1] for listing each of two symptoms of nut allergy [2 max].*  
mouth and lips tingling;  
face swelling;  
feeling sick;  
urticaria (nettle rash or hives);  
colicky pains in your abdomen (tummy or stomach);  
a feeling of tightness around your throat;  
wheezing or difficulty breathing due to an asthma-like attack, or swelling around your throat;  
dilation of blood vessels which can cause skin redness of your skin, a fast heart rate and low blood pressure; *[2 max]*
- (b) *Award [1] for outlining one reason why the label offers information relating to nuts and [1] for a brief explanation [2 max].*  
nut allergies are increasingly common;  
potential consumers with nut allergies are looking for assurances about the likelihood of products containing nuts;  
the company could be sued if “cannot guarantee nut free” is not included; *[2 max]*
- A4.** *Award [1] for an example and [1] for each of two points of explanation of how chronic and acute food-related issues impact on a developed country’s health services [3 max] per issue, [6 max].*  
*Chronic food related issue:*  
*e.g. diabetes / obesity;*  
long-term dependency on health services but not at acute level;  
financial implications for public purse;  
some of these problems are avoidable with increased levels of health awareness by the general public;
- Acute food related issue:*  
*e.g. food-poisoning incident in a hotel, restaurant or institution;*  
large numbers of people can be affected simultaneously;  
short-term, potentially overwhelming, impact on health services; *[6 max]*

- A5.** (a) *Award [1] for outlining one way in which population growth poses challenges to the achievement of MDG1 and [1] for a brief explanation [2 max].*  
more people to feed, more food required;  
more difficult to achieve MDG1; [2]
- (b) *Award [1] for outlining one way in which climate change contributes to food insecurity and the achievement of MDG1 and [1] for a brief explanation [2 max].*  
climate change is leading to extreme weather conditions and drought and flooding;  
this can make crops fail and reduce food security; [2]
- (c) *Award [1] for outlining one reason why the production of higher yielding cultivars of food crops is a more ethically-appropriate solution than genetic engineering for combating food insecurity and [1] for a brief explanation [2 max].*  
public concerns over the safety of genetically-modified crops and therefore the ethical appropriateness of using them for combating food insecurity;  
higher yielding cultivars can produce more and better food without resorting to genetic engineering; [2]
- A6.** (a) *Award [1] for each of three distinct correct points in an explanation of how an understanding of temperature growth curves for food bacteria influences the design of ready meals [3 max].*  
the data is used to design food which is less susceptible to bacterial growth;  
and provides consumers with instructions/guidance;  
relating to storage/reheating/use by date; [3]
- (b) *Award [1] for each of three distinct correct points in a suggestion of one reason why the increased consumption of ready meals in developed countries may be a factor in the rise of food poisoning incidents. [3max].*  
inadequate heating;  
instructions not always followed;  
ignorance about the importance of re-heating the food correctly;  
  
inadequate storage;  
food not stored at the correct temperature;  
or stored beyond the use by date;  
  
must store in a refrigerator or cool cabinet above any raw foods, especially meat;  
this will ensure that the ready meal is not dripped on;  
this would contaminate the food with microorganisms and unless properly stored could grow in the ready meal and cause food poisoning; [3 max]

**A7.** Award [1] for each of three distinct points in an explanation of how each of three different corporate strategies have contributed to the development of the global brand of Coca-Cola® [3 max] for each factor [9 max].

market penetration;

strong marketing of product and use of event sponsorship, e.g. Olympics;

raise public awareness of product;

market development;

identification of new markets for products;

e.g. sports drinks / low calorie/lite products;

product development;

add variations to a product;

e.g. new flavours (e.g. cherry coke);

diversification;

bottling of water and other soft drinks;

exploit benefits of established brand;

[9 max]

**Option B — Electronic product design**

**B1.** (a) Award [1] for indicating the correct gate for X:  
X = NOR ; [1]

(b) Award [1] for correctly stating what is used to convert an analogue signal to a digital signal and [1] for a description of how it works [2 max].  
schmitt trigger;  
switches to a digital signal when the analogue input voltage is above or below the switching threshold limits; [2]

(c) Award [1] each for correctly completing each column C, D and Q [3 max].

A	B	C	D	Q
0	0	1	0	0
0	1	0	0	1
1	0	0	0	1
1	1	0	1	0

[3 max]

**B2.** (a) Award [1] for a definition of a smart home to the effect of:  
a smart home is a residence that uses a home controller to integrate the various home automation systems [1]

(b) Award [1] for outlining an input device for a lighting system in a smart home and [1] for a brief explanation [2 max].  
light sensor;  
when the ambient light level drops below a predetermined threshold, the light comes on;

movement sensor;  
when a person moves in to an area, their movements are picked up and the light comes on; [2 max]



**B3.** (a) Award [1] for each drawing of two resistors connected to the input A terminal of the operational amplifier and the power source.

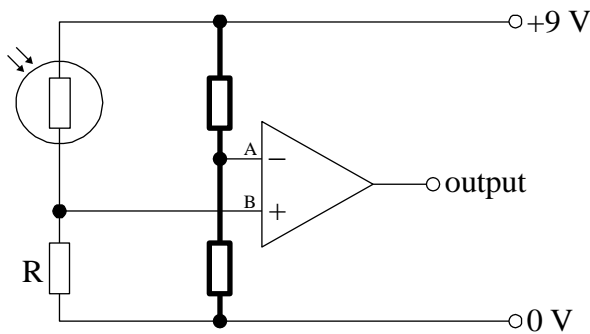

[2]

(b) Award [1] for identifying what would determine the upper extreme and [1] for identifying the lower extreme of the range of appropriate ratings for the components added in response to part (a) [2 max].

too high a value would affect the input impedance/current to the comparator / noise immunity of the reference input to the comparator would be compromised;  
too low a value would flatten the battery/dissipate a lot of watts;

[2]

**B4.** Award [1] for each of three distinct points in a discussion of two ways in which PIC technology can be regarded as sustainable [3 max] per way.

extends the life of a product;  
reprogrammable/downloads software upgrades;  
overcomes planned obsolescence;

materials;  
reduction in number of components;  
small volume of materials used to create the (silicon) chip;

energy;  
low energy requirements for use;  
reduction in energy requirements for manufacture;

disposal;  
the (silicon) chip is non-toxic;  
will not harm the environment;  
suitable for re-use;

[6 max]

- B5.** (a) *Award [1] for each point in an outline of one reason why very high speed data transmission is needed in the implementation of “The Communicator” [2 max].*  
to achieve real-time/synchronous interaction;  
communication must be spontaneous/instant; **[2]**
- (b) *Award [1] for identifying a key component of “The Communicator” and [1] for a brief description.*  
individual information component;  
models itself on a particular individual;  
  
avatar component;  
uses virtual people to simulate human form;  
  
environmental interface component;  
provides opportunities to enhance communication and education; **[2 max]**
- (c) *Award [1] for identifying how productivity can be enhanced by the use of “The Communicator” for a multi-national company and [1] for a brief explanation.*  
communication is required in a global context;  
overcomes linguistic barriers;  
  
reduces the need for travel;  
more people can be involved in global collaborations/more inclusive; **[2 max]**

**B6.** (a) *Award [1] for identifying an advantage and [1] for each of two points in a discussion relating to the advantage for the consumer of a mobile phone designed for disassembly.*

upgradeability;

mobile phones can include software upgrades;

new technology can be incorporated;

maintenance;

components can easily be repaired or replaced;

extending the product's lifespan;

customisation;

designs can be individualised;

making the item more unique/personalised;

*[3 max]*

(b) *Award [1] for identifying an issue relating to take-back legislation in disposal of electronic products and [1] for each of two points in an explanation which relates to the issue [3 max].*

consideration of the materials;

lightweighting;

so there is less material to dispose;

the use of recycled or recyclable materials should be maximised;

limit the use of hazardous or toxic materials;

the phone needs to be easily disassembled;

joining methods need to be temporary, not permanent;

non-specialist tools/equipment for disassembly;

standardised parts;

so that they can be re-used or replaced;

which provides a return in the investment for the time to disassemble/facilitates repair/upgrade;

*[3 max]*

**B7.** Award [1] for stating each of three advantages of using optical fibre for transferring information in a communication system and [1] for each of two points of explanation [3 max] per advantage.

speed/bandwidth;

fibre optic networks operate at high speeds/large carrying capacity;

it can handle more data/serve more users;

no degradation of the signal;

signals can be transmitted further without needing to be refreshed/strengthened/  
amplified;

the signal can travel further distances;

interference;

greater resistance to electromagnetic noise such as radios, motors or other nearby  
cables;

higher quality signal;

maintenance;

thinner and lighter than copper cable;

fibre optic cables costs less to maintain;

high level of security;

EM radiation cannot be intercepted;

as with electrical signals;

[9 max]

**Option C — CAD/CAM**

- C1.** (a) *Award [1] for stating a suitable tool that could be used in a CNC router to machine the part shown in Figure C3.*  
ball nose cutter; [1]
- (b) *Award [1] for each point in an outline of how the setting of the machine tool step-over variables will impact on the quality of the surface finish of the part shown in Figure C2.*  
a low setting;  
will give a smoother/more detailed surface finish; [2]
- (c) *Award [1] for each point in a discussion of the constraints of using a 3-axis machine for manufacturing the boat hull [3 max].*  
no allowance for any undercuts;  
has a flat base/can only cut from above;  
product has to be turned over to work on the underside; [3]
- C2.** (a) *Award [1] for stating a suitable modelling material for a CAM system.*  
modelling wax;  
high density foam;  
MDF;  
raflatec board;  
card; [1 max]
- (b) *Award [1] for each point in an outline of one benefit of surface modelling techniques for consumers [2 max].*  
consumer choice;  
colour/texture;  
  
realistic model of product;  
consumers can understand it easily/interpret the model accurately; [2 max]

- C3.** (a) *Award [1] for each point in an outline of **one** advantage of LOM as part of rapid prototyping.*  
cost;  
cheap materials can be used;
- size;  
larger working area/base; *[2 max]*
- (b) *Award [1] for listing two benefits of being able to rapid prototype a product [2 max].*  
small amount of waste due to the additive nature;  
able to provide internal structure;  
can produce a true 3D representation with no limiting factors;  
no need for dust extraction system; *[2 max]*
- C4.** *Award [1] for each point in a discussion of **two** benefits of using CAM when manufacturing the ring in Figure C4 [3 max] per benefit.*  
cost-effective;  
once fixed costs are covered;  
eliminates the need for expensive craft skills;
- type of design;  
very intricate/detailed;  
precision of CNC machining required;
- automated process;  
variety of techniques;  
integrated into one process;
- scale of production;  
if popular with consumers;  
can be easily produced in quantity; *[6 max]*

**C5.** (a) *Award [1] for each point in an outline of one effect of CAM on the workforce of a company wishing to move from traditional to modern manufacturing techniques [2max].*

loss of jobs;

less people needed to operate machines in the system;

redundant skills;

no sense of craftsmanship;

system of production will be very different;

retained staff will need retraining;

cleaner working environment;

less exposure to health hazards;

**[2 max]**

(b) *Award [1] for outline one way in which CAM has impacted on the design of kitchen cabinets [2 max].*

standardisation;

fixtures and fittings are standard sizes;

limitations of particular machines in the CAM system;

scope of the machines/types of materials that can be used;

cost effectiveness;

the cabinets need to be designed to optimize the manufacturing process;

**[2 max]**

(c) *Award [1] for each point in an outline of one impact of CAD on the nature of designer-client relationship [2max].*

designer can share ideas/costs easily/more quickly;

due to electronic communication;

interaction/feedback;

the client can influence the design process/cycle;

clients will have access to a wider range of designers;

they are not restricted by location/travelling distances for meetings;

range of techniques available to the designer improves the relationship;

client can have more realistic view of the end-product;

**[2 max]**

**C6.** (a) *Award [1] for each point in a comparison between use of humans and use of robots in relation to safety in a manufacturing system [3 max].*

robots can enter hazardous locations;  
reduces the need for people to undertake hazardous jobs/operations;  
reduction in accidents/illness;

robots do not suffer from fatigue;  
people get distracted/lose concentration when tired;  
reduction in accidents in the workplace;

feedback;  
faults in the manufacturing system will be identified immediately and shut the robots down;  
with humans, faults may not be detected until an accident occurs;

[3 max]

(b) *Award [1] for each point in a discussion of one advantage of using robots for batch production [3 max].*

cost-effective;  
cost is reduced making it cheaper to use robots instead of humans once capital costs are covered;

flexibility of programming;  
robots can be programmed to perform a large number of tasks/be adapted/reprogrammed to manufacture different products;

[3 max]

**C7.** *Award [1] for each of three distinct points in a discussion of how the use of Haptic Technology aids the design and use of virtual training in relation to user observation, training and feedback [3 max] per aspect.*

*User observation:*

enables the designer to observe the user's performance;  
and the range of ways in which people interact with the product/system;  
the designer uses this to improve the design of the product;

*Training:*

simulation;  
dangerous/difficult situations;  
e.g. bomb disposal/landing aircraft etc.;

*Feedback:*

sensors;  
provide a wide variety of information to the user;  
due to the sensitivity of the sensors;

[9 max]



**Option D — Textiles**

- D1.** (a) *Award [1] for one benefit for the manufacturer of using the fabric shown in Figure D1 in a car.*  
can be cut to shape;  
can join with other materials easily;  
easy to fit in confined spaces;  
cost-effective; **[1 max]**
- (b) *Award [1] for an advantage of the fabric being made by the technique of weaving and [1] for a brief explanation [2 max].*  
dimensional stability;  
it keeps its shape;  
  
cost-effective technique;  
easy to do;  
  
high strength to weight ratio;  
good tensile strength/lightweight;  
  
if cut on the cross;  
woven material will be able to be placed over complex curved surfaces; **[2 max]**
- (c) *Award [1] for each distinct point in an explanation of why the fabric is woven from a fire retardant fibre rather than being treated [3 max].*  
the fabric will be exposed to extreme temperatures;  
it needs to be fire retardant throughout not just on the surface;  
otherwise the fabric may be set alight and therefore not perform appropriately; **[3]**
- D2.** (a) *Award [1] for stating one limitation, apart from cost, to acceptance of wearable computing garments by consumers.*  
lack of understanding of the technology;  
cannot clean conventionally;  
no market pull;  
weight of batteries; **[1 max]**
- (b) *Award [1] for stating one way in which a manufacturer could develop a market for wearable computing garments and [1] for a brief explanation [2 max].*  
develop a marketing strategy;  
targeting particular market segments;  
  
persuade people of the benefits of the product;  
through promotion/advertising; **[2 max]**

- D3.** (a) *Award [1] for a distinct point and [1] for clarification of the point relating to one advantage to the consumer of textile labelling [2 max].*  
shows care instructions;  
so can determine cleaning costs prior to purchase/cleaning requirements after purchase/which domestic appliances can be used with the garment; **[2]**
- (b) *Award [1] for each correct point relating to one benefit to the manufacturer of using graphical images on the labels [2 max].*  
international symbols;  
no linguistic interpretation;
- global market for garments/cost-effective;  
don't need different labels for different countries; **[2 max]**
- D4.** *Award [1] for each distinct point in a discussion of two issues relating to the use of this type of packaging for the display of shirts in retail stores [3 max] per issue*  
environmental;  
the plastic packaging will be discarded by consumers after purchase;  
it could have a detrimental effect at disposal;
- transparent material;  
allows consumers to see the product;  
but prevents consumers from handling and soiling the product;
- consumers cannot feel the fabric;  
often cannot see all of the labelling;  
in order to decide if you want to purchase the shirt;
- consumers cannot try the shirt on to test for fit;  
without taking the shirt out of the package;  
the shirt will not fit neatly back into the package; **[6 max]**

- D5.** (a) *Award [1] for each point in an outline of one reason why preserving the cotton industry is important for social sustainability [2 max].*  
cotton is a major industry in some parts of the world/many developing countries;  
lots of peoples livelihoods are tied to the cotton industry; **[2]**
- (b) *Award [1] for each point in an outline of one environmental issue related to the cultivation of cotton [2 max].*  
pesticides;  
negative impact on the ecosystem;  
  
water;  
cotton is grown in hot climates where using water for irrigation is a major concern;  
  
increased pressure on agricultural land use for food;  
the owners of the cotton plantation are focused on cultivating as much cotton as possible for profit; **[2 max]**
- (c) *Award [1] for one impact of quotas on the economics of the cotton industry and [1] for a brief explanation.*  
some countries (especially developing countries) are heavily reliant on the cotton industry;  
export and import quotas are a controversial aspect of trying to regulate the industry; **[2]**

**D6.** (a) *Award [1] for each of three distinct points in a discussion of one impact of the maintenance of textiles in the home on health [3 max].*

textiles are often pre-treated;  
consumers are not aware of the nature of the pre-treatment;  
this may have an adverse effect on humans and pets;

use of chemicals/processes by consumers after purchase in the home;  
may react with pre-treatments or inappropriate maintenance products are used;  
which cause respiratory/skin problems;

*[3 max]*

(b) *Award [1] for a distinct point and [1] for each clarification of point relating to one way in which improvements in care and maintenance of clothing has had a benefit to the environment [3 max].*

low temperature detergents developed;  
still cleans clothes as well;  
less energy used to heat water;

development of low water use washing machines;  
use less water to run a cycle;  
less water needs to be processed;

many detergents are biodegradable;  
so they degrade quickly;  
and don't impact on the environment negatively;

stronger detergents;  
use less detergent;  
less detergent to damage the environment;

development of low maintenance fabrics removes need for ironing;  
no energy to power the iron;  
reduced impact on the environment;

*[3 max]*

**D7.** Award [1] for each point in a discussion of three ways in which textile materials can contribute to the enhanced performance of sportsmen/sportswomen [3 max] for each improvement.

development of Fastskin<sup>®</sup>;  
which mimics sharks skin;  
reduces drag/less resistance in water and therefore increases speed;

Lycra<sup>®</sup>;  
tighter-fitting clothes;  
therefore less wind resistance therefore more speed;

Lycra<sup>®</sup>/compression sportswear;  
keeps muscles warm;  
prevents muscle strain and fatigue;

Lycra<sup>®</sup>/compression sportswear;  
wicks sweat away from body;  
prevents chafing/skin problems;

Gore-tex<sup>®</sup>;  
breathable fabric;  
more comfortable clothes, less sweating, better performance;

3SP<sup>®</sup>;  
warmth without bulk/enhanced breathability/stretch/wind-proofness/water repellence/comfort;  
sportspersons in cold weather conditions can wear lighter/more flexible clothing;

physiological monitoring of sportspeople during exercise;  
for example breathing rates / sweat monitoring;  
can help to monitor training and ensure optimal performance;

DEFLEXION<sup>™</sup>;  
can be used to make body armour;  
protects sportsperson from high energy impacts;

swimsuits coated with nanoparticles;  
repel water;  
reduces drag;

[9 max]

**Option E — Human factors design**

- E1.** (a) *Award [1] for stating the reason for the position of the dishwasher in the kitchen layout.*  
adjacent to the sink so easy access to plumbing; [1]
- (b) *Award [1] per distinct point in a description of the purpose of the use of a kitchen work triangle for the designer.*  
to work out the optimum arrangement to position appliances for maximum safety and efficiency;  
shortest distance to travel with hot containers/plates/meals; [2]
- (c) *Award [1] per distinct point in an explanation of how the work triangle can improve safety for users of the kitchen.*  
sufficient circulation space allowed for using appliances;  
considering the relationship between each appliance for use minimizes risk;  
efficient arrangement reduces fatigue/number of journeys between each appliance for the user; [3]
- E2.** (a) *Award [1] for stating one reason why the lid of a jar is usually fastened tightly at the end of the manufacturing process [1 max].*  
reduces chance of spillage during transport;  
for safety as it limits tampering/contamination of content; [1 max]
- (b) *Award [1] for each point in an outline of one bodily tolerance involved with unscrewing the lid of a jar [2 max].*  
grip/torque;  
the amount of force needed to undo the lid;  
  
comfort;  
the degree of discomfort for the user when opening the jar; [2 max]
- E3.** (a) *Award [1] per distinct point in a description of the function of the instrument in Figure E2.*  
used to collect data relating to body parts;  
the calipers measure the size of the parts *e.g.* hand size; [2]
- (b) *Award [1] per distinct point in an outline of one limitation of the use of the instrument in Figure E2 for collecting anthropometric data [2 max].*  
difficult to collect very accurate data relating to body parts;  
due to the amount of fat on people’s body/amount of pressure applied may vary from person to person;  
  
people may be measured wearing clothes;  
and the thickness of the clothes can vary from person to person; [2 max]

- E4.** Award [1] for each distinct point in a suitable discussion relating to the impact of adjustability [3 max] and range of sizes [3 max] on the global market for clothing.  
range of sizes provided to appeal to a wide range of percentiles;  
percentile ranges vary per user population in different regions of the world;  
clothing sizes match these regional variations;
- adjustability provided so users within a particular size range;  
can adjust the item of clothing to obtain an individual fit;  
e.g. the strap on a baseball cap; [6]
- E5.** (a) Award [1] for each distinct point in a suitable outline of one reason why the concept of “design for discomfort” may be used in the design of public seating in railway stations.  
so the station does not become a social meeting/refuge point for non-rail users;  
therefore encourages train users to limit the amount of time they are seated  
creating availability for other train users; [2]
- (b) Award [1] per distinct point in an outline of one piece of dynamic human factors data which is important to the designer of public seating [2 max].  
how users get in/out of the seat;  
so the designer can ensure the seat is safe/easy to use; [2]
- (c) Award [1] per distinct point in an outline of one security issue which has affected the design of seating in airports [2 max].  
fear of a terrorist attack;  
seats are not enclosed so it is easy to see under them; [2]
- E6.** (a) Award [1] per distinct point in an explanation of the relationship between user trial and motion capture to the development of a digital human [3 max].  
a motion capture session records the movements of a person performing a user trial;  
e.g. using a kettle;  
the captured movements are mapped to a 3D model created by a computer expert  
so that the model moves digitally; [3]
- (b) Award [1] for each distinct point in an explanation of how the use of digital humans can assist the designer of a car to deal with the problem of designing the car for a wide percentile range [3 max].  
ensures that people of different sizes will be able to use all the controls effectively/ see out of the windows;  
ensures that the users can climb in and out of the vehicle easily;  
ensures that the strength required to operate the controls is within the normal range;  
ensures that foot pedals can be reached by users in the normal percentile range; [3 max]

**E7.** Award [1] for each distinct point in an explanation of why feedback, mapping and affordance are important in human factors design [3 max] for each aspect.

feedback is the provision of information as a result of an action;

*e.g.* an audible or visual response to pressing a control;

so the user can decide how to respond;

mapping relates to the correspondence between the layout of controls;

and their required action;

*e.g.* making important controls most visible;

affordance is the characteristic of an object that indicates how it is to be used;

*e.g.* turning a control knob in the right direction;

to limit confusion and ensure safety/efficiency;

[9]

---