

**DESIGN TECHNOLOGY
HIGHER LEVEL
PAPER 2**

Candidate number

--	--	--	--	--	--	--	--

Wednesday 14 May 2003 (afternoon)

1 hour 45 minutes

INSTRUCTIONS TO CANDIDATES

- Write your candidate number in the box above.
- Do not open this examination paper until instructed to do so.
- Section A: answer all of Section A in the spaces provided.
- Section B: answer one question from Section B. Write your answers on answer sheets. Write your candidate number on each answer sheet, and attach them to this examination paper and your cover sheet using the tag provided.
- At the end of the examination, indicate the numbers of the questions answered in the candidate box on your cover sheet and indicate the number of sheets used in the appropriate box on your cover sheet.

SECTION A

Answer **all** the questions in the spaces provided.

1. Safety is a key consideration in the design of children's playgrounds. One aspect of safety relates to the nature of play surfaces. A child falling from a height, *e.g.* a slide (see **Figure 1** and **Figure 2**), can sustain broken bones and head injuries. Various materials, *e.g.* chopped tree bark or tiles made from recycled rubber car tyres, can be used to absorb impact and minimize injuries. One manufacturer supplies four different thickness tiles - thicker tiles are used where children can fall from greater heights (see **Table 1**). The tiles are 500 mm by 500 mm squares and are glued onto a concrete base that is laid onto a compacted stone base on firm sub-soil (see **Figure 3**). Care needs to be taken in the preparation of the compacted stone base to ensure that it is flat and that the correct final level will be achieved when the concrete base and the tiles are laid on.

Figure 1

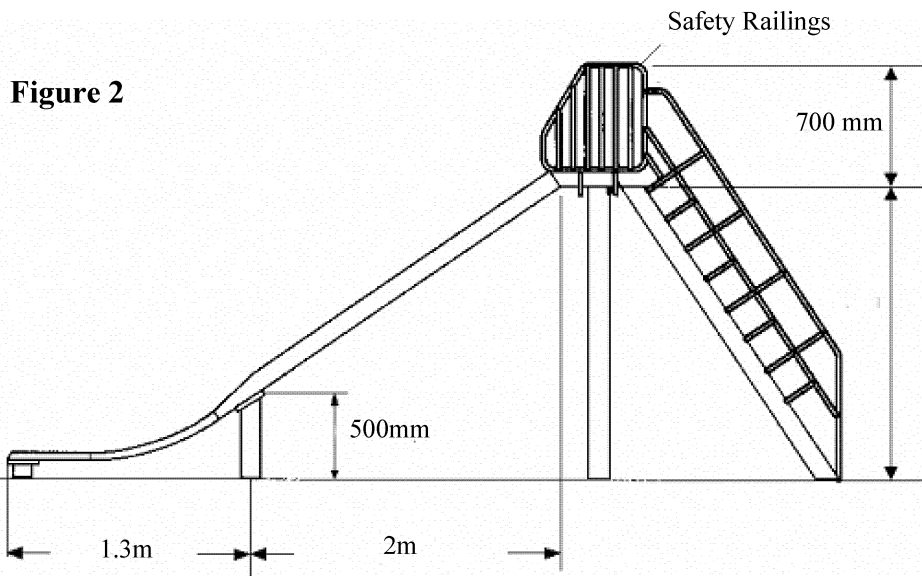

Figure 3

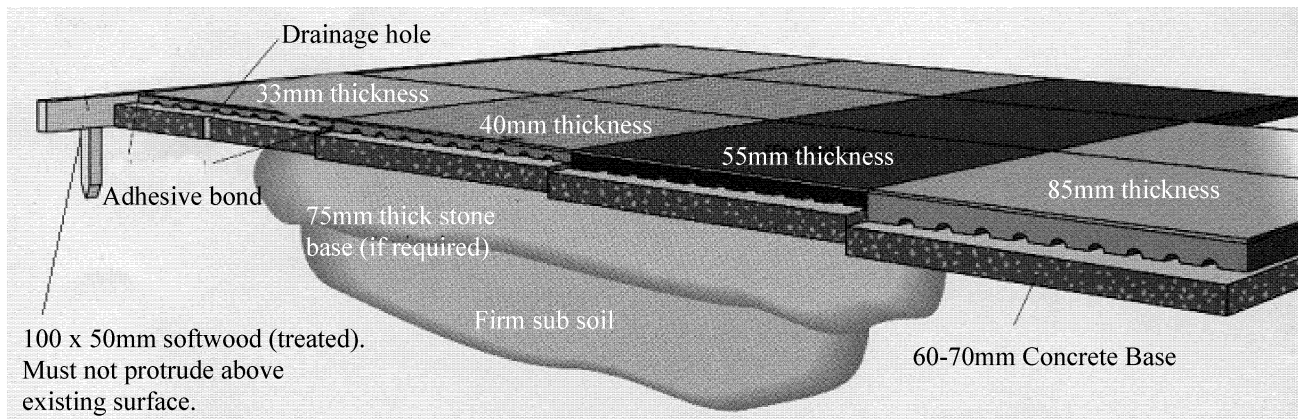
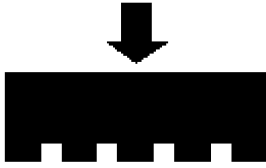

Table 1

	Tile number	Tile 1	Tile 2	Tile 3	Tile 4
	Tile thickness (mm)	33	40	55	85
	Recommended maximum safe height of fall (m)	1.2	1.4	2.0	2.6
	Cost per tile (\$)	80	120	160	200

(a) (i) State **one** advantage of using tiles rather than chopped bark for the play surface in the childrens' playground. [1]

.....

(ii) State the least thickness of tile that could be safely used for the play surface at the lower end of the slide. [1]

.....

(iii) Calculate the maximum height from which a child could fall whilst using the slide. [2]

.....

.....

The designer is evaluating two options for tiling the playground – one option uses thinner tiles around the bottom of the slide and thicker tiles elsewhere, the other uses thicker tiles across the whole area.

(b) (i) State **one** advantage of using a combination of thinner and thicker tiles rather than thicker tiles alone. [1]

.....

(ii) Explain why the option of using just thicker tiles for the whole area rather than a combination of thinner and thicker tiles enables a flat play surface to be constructed more easily. [3]

.....

.....

.....

.....

.....

(This question continues on the following page)

(Question 1 continued)

- (c) (i) Outline **one** appropriate strategy to evaluate the maximum safe height of fall onto the tiles. [2]

.....

.....

.....

.....

- (ii) List **two** disadvantages of using this strategy to collect data in this design context. [2]

.....

.....

.....

.....

Figure 4 and **Figure 5** below show slides made of different materials. **Figure 4** shows a polyethylene slide reinforced with tubular steel – the slide has a design load of 200 kg. **Figure 5** shows a stainless steel slide that has a design load of 250 kg.

Figure 4



Figure 5

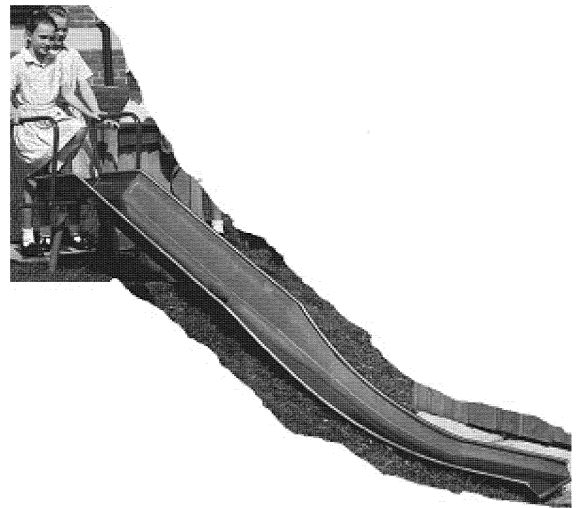

- (d) (i) List **two** reasons why the stainless steel slide would be more suitable for a public playground than the thermoplastic slide. [2]

.....

.....

.....

(This question continues on the following page)

(Question 1(d) continued)

- (ii) Outline **one** reason why the thermoplastic slide is reinforced with tubular steel. [2]

.....

.....

.....

.....

- (e) (i) The 95th percentile weight for a child aged 12 years is 50 kg. Calculate the factor of safety for the stainless steel slide when used by one child. [2]

$$\text{factor of safety} = \frac{\text{design load}}{\text{normal maximum load}}$$

.....

.....

- (ii) Suggest **one** reason for the high factor of safety. [2]

.....

.....

.....

.....

2. Safety railings can be produced from metal tubing. Metal tubing of different square and circular cross sections can be produced by extrusion.

- (a) State **one** advantage of extrusion for the production of metal tubing. [1]

.....

- (b) Explain how safety railings would be produced from metal tubing. [3]

.....

.....

.....

.....

.....

3. (a) Define *automated guided vehicle (AGV)*. [1]

.....
.....

(b) Explain how AGVs can contribute to an automated production system. [3]

.....
.....
.....
.....
.....

4. (a) Define *radical design*. [1]

.....
.....

(b) Explain how design work is often a combination of incremental and radical design. [3]

.....
.....
.....
.....
.....

5. (a) Define *thermal expansion*. [1]

.....
.....

(b) Explain a design context where thermal expansion is an important consideration. [3]

.....
.....
.....
.....
.....

6. (a) List **two** nutritional advantages of mycoprotein. [2]

.....
.....
.....
.....

(b) Outline how mycoprotein is produced. [2]

.....
.....
.....
.....

SECTION B

Answer **one** question. Write your answers on the answer sheets provided. Write your candidate number on each answer sheet, and attach them to this examination paper and your cover sheet using the tag provided.

7. Consumers are faced with a bewildering range of options when contemplating the purchase of kitchen appliances. Stainless steel is an extremely fashionable material for kitchen appliances and can be plastically deformed in the manufacture of components for the appliances. **Figure 6** shows a stainless steel refrigerator and **Figure 7** shows its energy label.

Figure 6



Figure 7



- (a) (i) Define *plastic deformation*. [1]
- (ii) Describe the difference between elastic and plastic strains. [2]
- (iii) Outline **one** reason why stainless steel is suitable for use in the manufacture of kitchen appliances. [2]
- (b) (i) Outline **one** way in which thermal conductivity of the insulation material in the casing of the refrigerator contributes to the energy efficiency of the refrigerator. [2]
- (ii) Identify **one** potential source of thermal conductivity data for designers. [2]
- (c) (i) Outline how energy–labelling schemes can help consumers compare potential purchases. [2]
- (ii) Discuss the implications of fashion and planned obsolescence for conserving natural resources and pollution. [9]

8. A boat building company has traditionally manufactured wooden boats (see **Figure 8**) using mechanized techniques. Recently the company has decided to diversify and has started to manufacture boats in a traditional style using a composite material (see **Figure 9**).

Figure 8

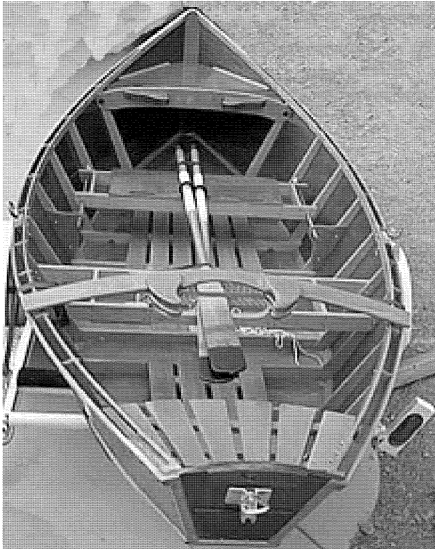

Figure 9



- (a) (i) Describe the structure of wood as a natural composite material. [2]
- (ii) Outline **one** synthetic composite suitable for boat building. [2]
- (b) (i) Define *batch production*. [1]
- (ii) Outline **one** advantage of mechanization for the production of the boats. [2]
- (iii) Outline **one** impact of the new design on the manufacturing process. [2]
- (c) (i) Outline why composite materials cannot be easily recycled. [2]
- (ii) Explain how the strategies for green design of repair and recycle can be applied to the two boats. [9]

9. **Figure 10** and **Figure 11** show egg cartons produced using different materials and different technologies. The first egg carton (see **Figure 10**) is made of polystyrene and moulded using injection moulding techniques. The second egg carton (see **Figure 11**) is made from papier-mâché produced from recycled paper by pressing the papier-mâché into a simple mould and then drying using hot air or simply air-drying in the sun.

Figure 10



Figure 11

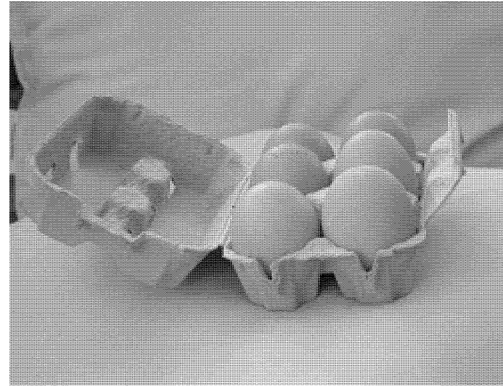

- (a) (i) Define *injection moulding*. [1]
- (ii) List **two** advantages of using injection moulding for the production of egg cartons. [2]
- (iii) Outline how one-off production contributes to the volume production of the polystyrene egg cartons. [2]
- (b) (i) Outline **one** reason why the papier-mâché egg cartons can be considered as an alternative technology. [2]
- (ii) Outline **one** reason why papier-mâché egg cartons can be considered as an appropriate technology. [2]
- (c) (i) Outline **one** way in which injection moulding can be considered a clean technology. [2]
- (ii) Explain the benefits to the company of adopting the use of papier-mâché egg cartons as part of a proactive environmental policy. [9]