

SECTION A

Answer **all** questions.

1. State which data type is best for storing a telephone number (e.g. 01623 440325) and give **two** reasons why. [3 marks]
2. State what type of search would always be used on unsorted data and explain why. [2 marks]
3. Explain what is meant by a *transaction* file. [3 marks]
4. State **two** items that would be found in *system documentation* and explain why it is necessary to produce *system documentation*. [4 marks]
5. State the 8 bit, two's complement of -91. Show your working. [2 marks]
6. State whether or not the even parity byte 0111 0110 has been corrupted. [1 mark]
7. Describe **one** "safe" method of upgrading a networked computer system. Explain how it could be used to avoid a catastrophic failure. [3 marks]
8. Compare procedures and functions by describing how each handles parameters and return values. [5 marks]
9. Explain the difference between *logical*, *syntax* and *run-time* errors. [3 marks]
10. State the function of the *mantissa* and *exponent* in the representation of a *floating point* number. [2 marks]
11. Explain why a large signed integer will sometimes be interpreted by a *compiler* as a negative number. [2 marks]
12. State when you would use an *interpreter* and explain why. [2 marks]

13. Explain the meaning of *polymorphism* in *object oriented programming*. [3 marks]
14. State, using big O notation, the efficiency of each of the following:
- (a) a linear search;
 - (b) a bubble sort;
 - (c) a quicksort. [3 marks]
15. Explain why it is important for the general public to have access to databases which store information about them. [2 marks]

SECTION B

Answer four questions.

16. The start of a trace table for the following algorithm is given below.

```

procedure P(val I integer)
  declare C, D integer
  declare A integer array [0..7]
  D <-- 128
  for C <-- 0 upto 7 do
    A[7-C] <-- I div D
    if A[7-C] = 1 then
      I <-- I-D
    endif
    D <-- D div 2
  endfor
endprocedure P
  
```

I	C	D	A[7]	A[6]	A[5]	A[4]	A[3]	A[2]	A[1]	A[0]
197	0	128	1							
69	1	64	1	1						

- (a) Copy and complete the truth table. [6 marks]
- (b) State the function of procedure P. [1 mark]

Another procedure has been written that performs a similar task.

```

procedure P1(val I short integer)
1   declare A, B integer
2   declare C, D char declare N string
3   N = "0123456789ABCDEF"
4   A <-- I div 16
5   B <-- I mod 16
6   C <-- N[A]
7   D <-- N[B]
endprocedure P1
  
```

- (c) State the purpose of lines 4 and 5. [1 mark]
- (d) State the purpose of lines 6 and 7. [1 mark]
- (e) State the function of the procedure. [1 mark]

17. A database is used to store information about employees in order to calculate their wages. Two tables are used and the first few entries are reproduced below. (PK) means that the field is used as a primary key.

Table 1.

Name (PK)	HourlyRate
Smith. J	16
Doe. R	10
Brown. P	12
Green. T	16

Table 2.

Name (PK)	WeekNo (PK)	HrsWorked
Smith. J	1	35
Doe. R	1	37
Brown. P	1	35
Green. T	1	44

- (a) State why there are **two** primary keys in table 2. [2 marks]
- (b) State why the data is being stored in two tables instead of one larger table. [2 marks]
- (c) Describe how the tables could be accessed, using the primary keys, to calculate the wages for an employee in a specific week. [4 marks]
- (d) State **one** advantage and **one** disadvantage of using *direct access* to save and retrieve the data. [2 marks]

18. *Arrays or linked lists* can be used to implement *stacks* and *queues*.

- (a) State when you would use an *array* to implement a *stack* or a *queue*. [1 mark]
- (b) Describe the advantage of using an *array* to implement a *stack* or a *queue*. [1 mark]
- (c) Describe the advantage of a *linked list* to implement a *stack* or a *queue*. [1 mark]
- (d) Describe why *doubly linked lists* are not needed to implement *stacks* or *queues*. [2 marks]
- (e) Describe why a *circular linked list* is not needed to implement a *stack* or a *queue*. [2 marks]
- (f) Using diagrams, show how you would add and delete items from a *stack* implemented using a *linked list*. [3 marks]

19. The following logic circuit has three inputs, A, B and C. It has two outputs, H and L.

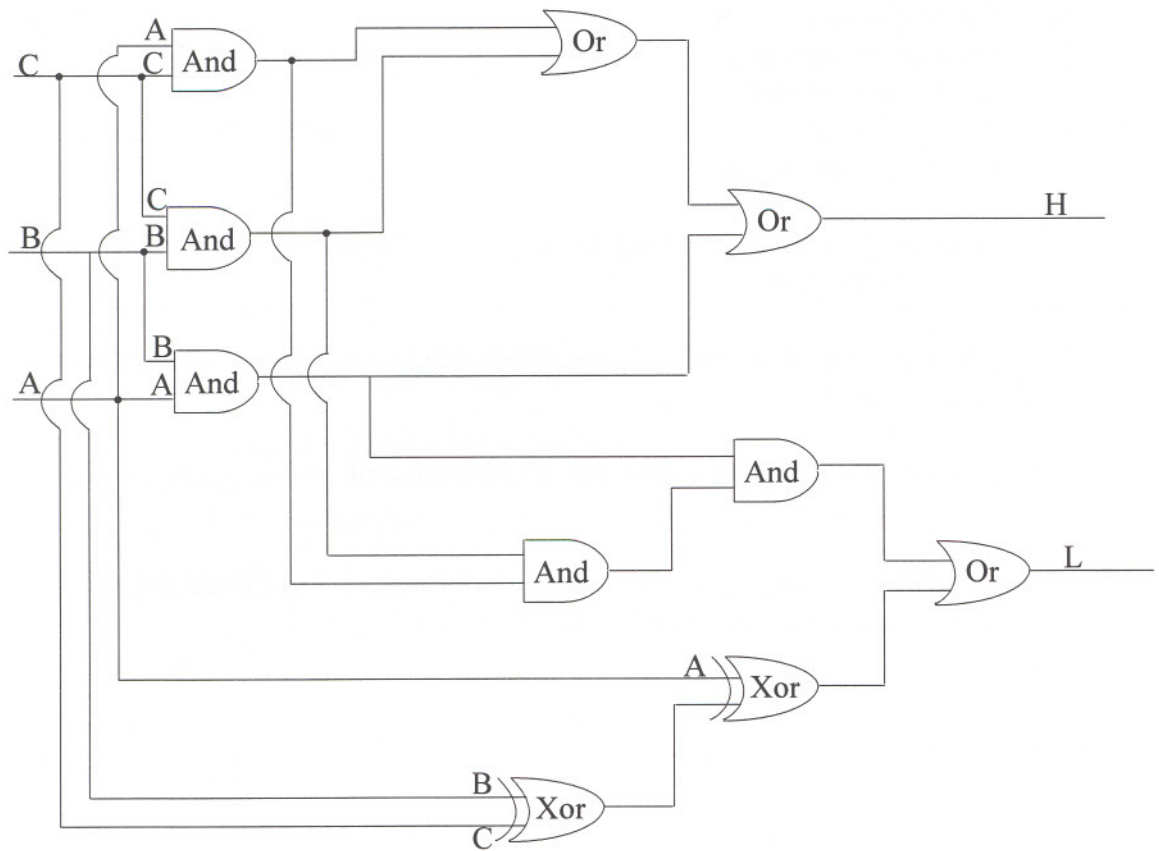

(a) Copy and complete the following truth table for the circuit.

[5 marks]

A	B	C	H	L
0	0	0	0	0
0	0	1	0	1

(b) State the name of this circuit.

[2 marks]

(c) The boolean expression for H can be written as:

$$H = A.B.\bar{C} + A\bar{B}C + \bar{A}BC + ABC$$

Simplify this expression and show your working.

[3 marks]

20. A typical operating system has five components that work together:

1. the user interface;
2. the process manager;
3. the device manager;
4. the file manager;
5. the memory manager.

- (a) Describe **one** advantage and **one** disadvantage of having a console (command line) user interface. *[2 marks]*
- (b) Describe **one** advantage and **one** disadvantage of having a menu as the user interface. *[2 marks]*
- (c) Describe **one** advantage and **one** disadvantage of having a GUI as the user interface. *[2 marks]*
- (d) Operating systems often use a system of interrupts to coordinate memory, devices and jobs. Describe how interrupts work. *[4 marks]*
-