

HONG KONG EXAMINATIONS AND ASSESSMENT AUTHORITY
HONG KONG DIPLOMA OF SECONDARY EDUCATION EXAMINATION

PHYSICS PAPER 1
(Sample Paper)

Time allowed: 2 hours 30 minutes
This paper must be answered in English

GENERAL INSTRUCTIONS

1. There are **TWO** sections, A and B, in this Paper. Section A consists of multiple-choice questions in this question book, while Section B contains conventional questions printed separately in Question-Answer Book B. You are advised to finish Section A in about 60 minutes.
2. Answers to Section A should be marked on the Multiple-choice Answer Sheet while answers to Section B should be written in the spaces provided in Question-Answer Book B. **The Answer Sheet for Section A and the Question-Answer Book for Section B must be handed in separately at the end of the examination.**

SECTION A (MULTIPLE-CHOICE QUESTIONS)

INSTRUCTIONS FOR SECTION A

1. Read the instructions on the Answer Sheet carefully. Stick a barcode label and insert the information required in the spaces provided.
2. When told to open this book, you should check that all the questions are there. Look for the words **'END OF SECTION A'** after the last question.
3. All questions carry equal marks.
4. **ANSWER ALL QUESTIONS.** You should use an **HB** pencil to mark all your answers on the Answer Sheet. Wrong marks must be completely erased.
5. You should mark only **ONE** answer for each question. If you mark more than one answer, you will receive **NO MARKS** for that question.
6. No marks will be deducted for wrong answers.

Not to be taken away before the
end of the examination session

There are 36 questions. Questions marked with “*” involve knowledge of the extension component. The back cover of this question paper contains a list of data, formulae and relationships which you may find useful.

1.

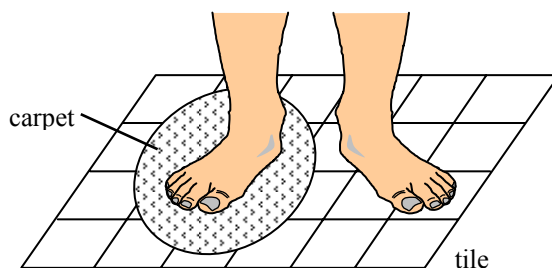

Cynthia places a piece of carpet on a tiled floor. After a while, she stands in bare feet with one foot on the tiled floor and the other on the carpet as shown above. She feels that the tiled floor is colder than the carpet. Which of the following best explains this phenomenon ?

- A. The tile is a better insulator of heat than the carpet.
- B. The tile is at a lower temperature than the carpet.
- C. The specific heat capacity of the tile is smaller than that of the carpet.
- D. Energy transfers from Cynthia's foot to the tile at a greater rate than that to the carpet.

2.

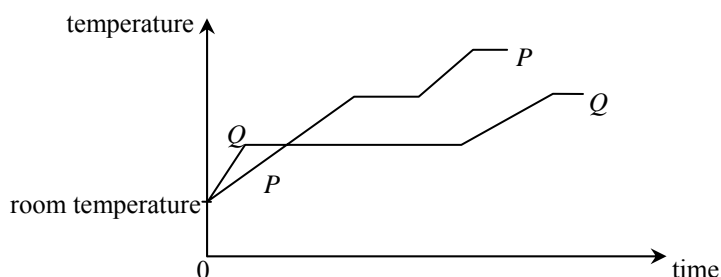

The graph shows the variation in temperature of equal masses of two substances P and Q when they are separately heated by identical heaters. Which deduction is correct ?

- A. The melting point of P is lower than that of Q .
- B. The specific heat capacity of P in solid state is larger than that of Q .
- C. The specific latent heat of fusion of P is larger than that of Q .
- D. The energy required to raise the temperature of P from room temperature to boiling point is more than that of Q .

*3.

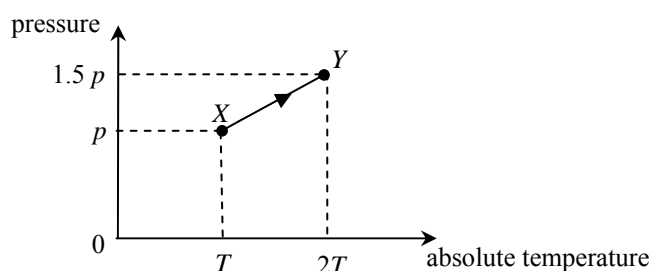

As the gas in a vessel of fixed volume is heated, it gradually leaks out. The gas in the vessel changes from state X to state Y along the path XY shown in the plot of pressure against absolute temperature. What percentage of the original mass of the gas leaks out from the vessel in this process ?

- A. 10%
- B. 20%
- C. 25%
- D. 50%

- *4. Two vessels contain hydrogen gas and oxygen gas respectively. Both gases have the same pressure and temperature and are assumed to be ideal. Which of the following physical quantities must be the same for the two gases?
- The volume of the gas
 - The mass per unit volume of the gas
 - The r.m.s. speed of the gas molecules
 - The number of gas molecules per unit volume

5.

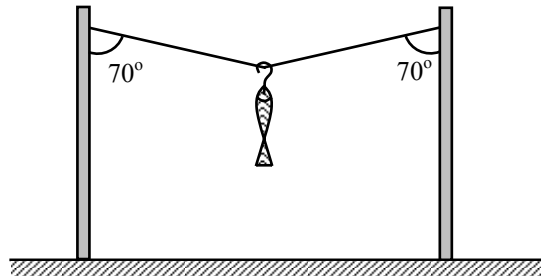

A fish is hung on a light string as shown above. The tension in the string is 10 N. Find the total weight of the fish and the hook.

- $20 \sin 70^\circ$ N
- $20 \cos 70^\circ$ N
- $10 \sin 70^\circ$ N
- $10 \cos 70^\circ$ N

6.

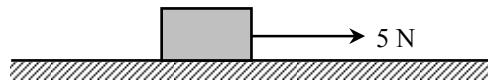

A 1 kg block is pulled by a horizontal force of 5 N and moves with an acceleration of 2 m s^{-2} on a rough horizontal plane. Find the frictional force acting on the block.

- zero
 - 2 N
 - 3 N
 - 7 N
7. Patrick is driving along a straight horizontal road. At time $t = 0$, he observes that an accident has happened. He then applies the brakes to stop his car with uniform deceleration. The graph shows the variation of the speed of the car with time.



Find the distance travelled by the car from time $t = 0$ to 5.0 s.

- 29.4 m
- 40.6 m
- 46.2 m
- 81.2 m

8.

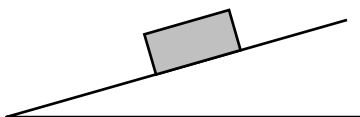

A block remains at rest on a rough inclined plane. Which diagram shows all the forces acting on the block ?

Note : W = gravitational force acting on the block,
 R = normal reaction exerted by the inclined plane on the block, and
 F = friction acting on the block.

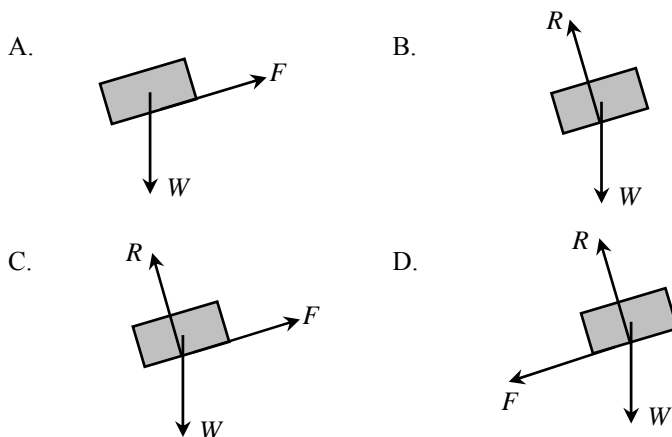

9. Kelvin is standing on a balance inside a lift. The table shows the readings of the balance in three situations.

Motion of the lift	Reading of the balance
moving upwards with a uniform speed	R_1
moving downwards with a uniform speed	R_2
moving upwards with an acceleration	R_3

Which relationship is correct ?

- A. $R_1 = R_2 > R_3$
- B. $R_3 > R_1 = R_2$
- C. $R_1 > R_2 > R_3$
- D. $R_3 > R_1 > R_2$

10.

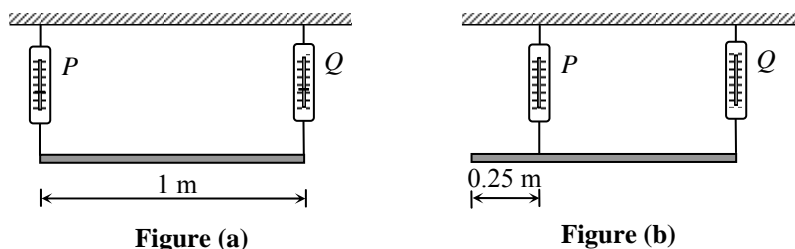
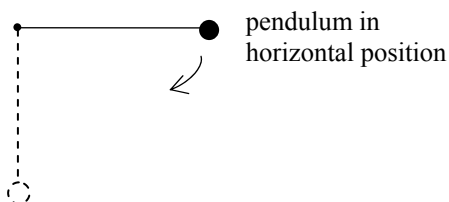

Figure (a) shows a uniform plank supported by two spring balances P and Q . The readings of the two balances are both 150 N. P is now moved 0.25 m towards Q (see Figure (b)). Find the new readings of P and Q .

- | | Reading of P/N | Reading of Q/N |
|----|------------------|------------------|
| A. | 100 | 200 |
| B. | 150 | 150 |
| C. | 200 | 100 |
| D. | 200 | 150 |

11. Which of the following pairs of forces is/are example(s) of action and reaction ?
- (1) The centripetal force keeping a satellite in orbit round the earth and the weight of the satellite.
 - (2) The air resistance acting on an object falling through the air with terminal velocity and the weight of the object.
 - (3) The forces of attraction experienced by two parallel wires carrying currents in the same direction.
- A. (1) only
B. (3) only
C. (1) and (2) only
D. (2) and (3) only
12. Two small identical objects P and Q are released from rest from the top of a building 80 m above the ground. Q is released 1 s after P . Neglecting air resistance, what is the maximum vertical separation between P and Q in the air ?
- A. 5 m
B. 10 m
C. 35 m
D. 45 m
13. A car P of mass 1000 kg moves with a speed of 20 m s^{-1} and makes a head-on collision with a car Q of mass 1500 kg, which was moving with a speed of 10 m s^{-1} in the opposite direction before the collision. The two cars stick together after the collision. Find their common velocity immediately after the collision.
- A. 2 m s^{-1} along the original direction of P
B. 2 m s^{-1} along the original direction of Q
C. 14 m s^{-1} along the original direction of P
D. 14 m s^{-1} along the original direction of Q

*14.



A simple pendulum is held at rest in a horizontal position. It is then released with the string taut. Which statement about the tension in the string is **not correct** when the pendulum reaches its vertical position ?

- A. The tension equals the weight of the pendulum bob in magnitude.
B. The tension attains its greatest value.
C. The tension does not depend on the length of the pendulum.
D. The tension depends on the mass of the pendulum bob.

15.

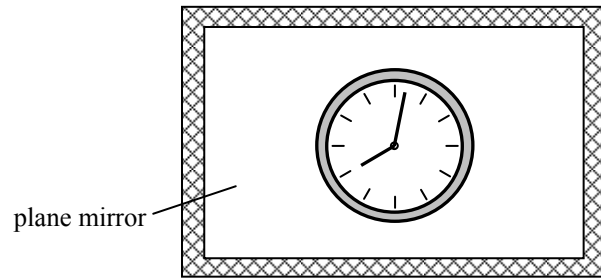

The diagram shows the image of a clock in a plane mirror. What is the time displayed by the clock ?

- A. 3:58
- B. 4:02
- C. 7:58
- D. 8:02

16.



Cecilia uses a magnifying glass to read some small print. Which diagram shows how the image of the print is formed ?

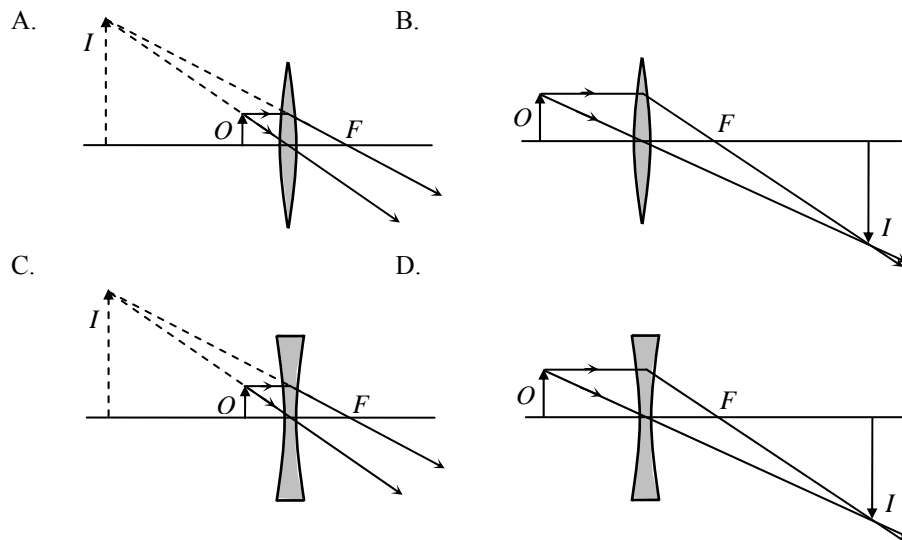

17.

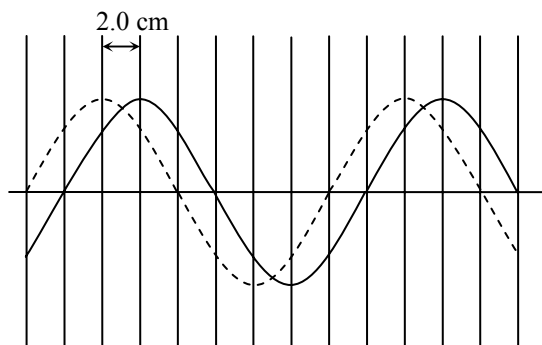

The solid curve in the diagram shows a transverse wave at a certain instant. After 0.05 s, the wave has travelled a distance of 2.0 cm and is indicated by the dashed curve. Find the wavelength and frequency of the wave.

	Wavelength/cm	Frequency/Hz
A.	8	2.5
B.	16	2.5
C.	8	5
D.	16	5

18.

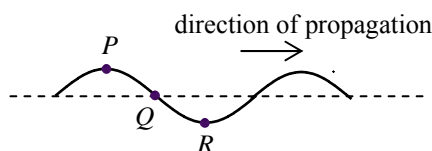

The figure shows the shape of a transverse wave travelling along a string at a certain instant. Which statement about the motion of the particles *P*, *Q* and *R* on the string at this instant is correct?

- A. Particle *P* is moving downwards.
- B. Particle *Q* is stationary.
- C. Particle *R* attains its maximum acceleration.
- D. *P* and *Q* are in phase.

19.

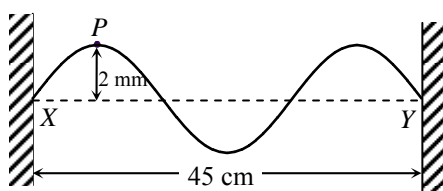

String *XY* is fixed at both ends. The distance between *X* and *Y* is 45 cm. Two identical sinusoidal waves travel along *XY* in opposite directions and form a stationary wave with an antinode at point *P*. The figure shows the string when *P* is 2 mm, its maximum displacement, from the equilibrium position. What is the amplitude and wavelength of each of the **travelling waves** on the string?

	Amplitude	Wavelength
A.	1 mm	30 cm
B.	1 mm	15 cm
C.	2 mm	30 cm
D.	2 mm	15 cm

20. A Young's double-slit experiment was performed using a monochromatic light source. Which would result in a greater fringe separation on the screen ?
- (1) Using monochromatic light source of longer wavelength
 - (2) Using double slit with greater slit separation
 - (3) Using double slit with larger slit width
- A. (1) only
 - B. (1) and (2) only
 - C. (2) and (3) only
 - D. (1), (2) and (3)
21. An object is placed at the focus of a concave lens of focal length 10 cm. What is the magnification of the image formed ?
- A. 0.5
 - B. 1.0
 - C. 2.0
 - D. infinite
22. Which of the following statements about sound waves is/are correct ?
- (1) Sound waves are longitudinal waves.
 - (2) Sound waves are electromagnetic waves.
 - (3) Sound waves cannot travel in a vacuum.
- A. (2) only
 - B. (3) only
 - C. (1) and (2) only
 - D. (1) and (3) only

23.

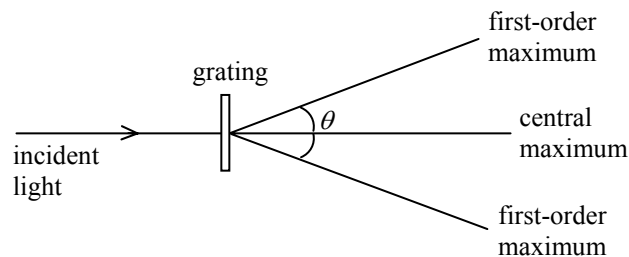

When monochromatic light is passed through a diffraction grating, a pattern of maxima and minima is observed as shown. Which combination would produce the largest angle θ between the first-order maxima ?

	Grating (lines per mm)	Colour of light used
A.	200	blue
B.	200	red
C.	400	blue
D.	400	red

24. Two conducting spheres are hanging freely in air by insulating threads. In which of the following cases, the two spheres attract each other ?

Note : 'N' denotes that the sphere is uncharged.

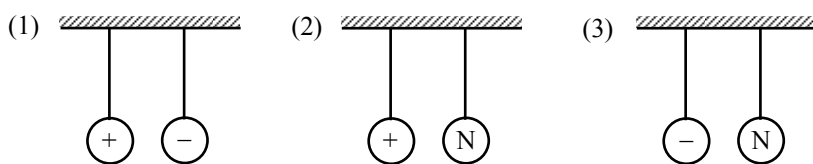

- A. (1) only
 B. (2) only
 C. (3) only
 D. (1), (2) and (3)

25. The table shows three electrical appliances which Clara used in a certain month :

Appliance	Rating	Duration
Air-conditioner	220 V, 1200 W	250 hours
television	220 V, 250 W	80 hours
computer	220 V, 150 W	60 hours

Calculate the cost of electricity used.

Note : 1 kW h of electricity costs \$ 0.86.

- A. \$ 62.25
 B. \$ 73.79
 C. \$ 282.94
 D. \$ 536.64
26. If a 15 A fuse is installed in the plug of an electric kettle of rating '220 V, 900 W', state what happens when the kettle is plugged in and switched on.
- A. The kettle will not operate.
 B. The kettle will be short-circuited.
 C. The output power of the kettle will be increased.
 D. The chance of the kettle being damaged by an excessive current will be increase
- 27.

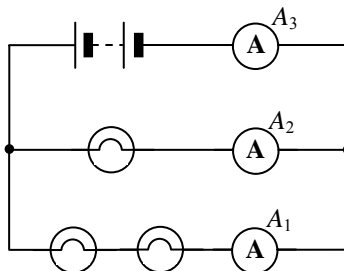

In the above circuit, the bulbs are identical. The reading of ammeter A_1 is 1 A. Find the readings of ammeters A_2 and A_3 .

- | | Reading of A_2 | Reading of A_3 |
|----|------------------|------------------|
| A. | 2 A | 2 A |
| B. | 2 A | 3 A |
| C. | 0.5 A | 1 A |
| D. | 0.5 A | 1.5 A |

28.

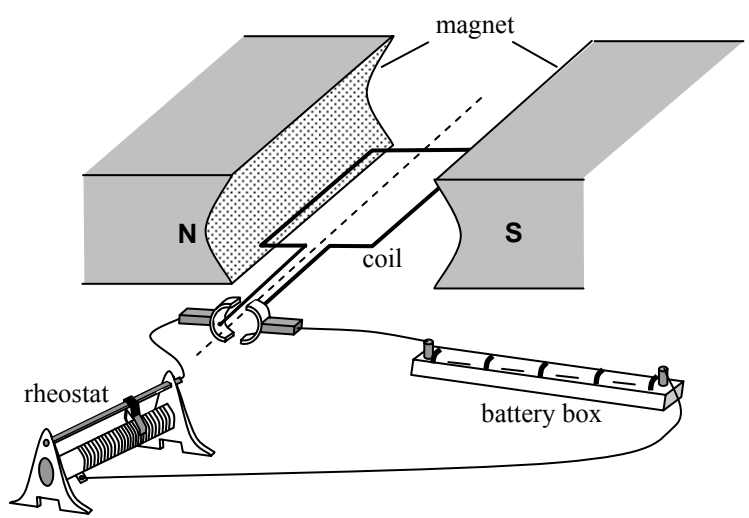

The figure shows a simple motor. Which of these changes would increase the turning effect of the coil ?

- (1) using a stronger magnet
 - (2) reducing the resistance of the rheostat
 - (3) using a coil with a smaller number of turns
- A. (1) and (2) only
 - B. (1) and (3) only
 - C. (2) and (3) only
 - D. (1), (2) and (3)

29.

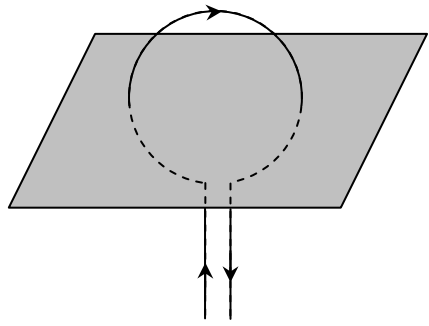

Which diagram shows the magnetic field pattern around a flat circular current-carrying coil, in the plane shown ?

- A.
- B.
- C.
- D.

30.

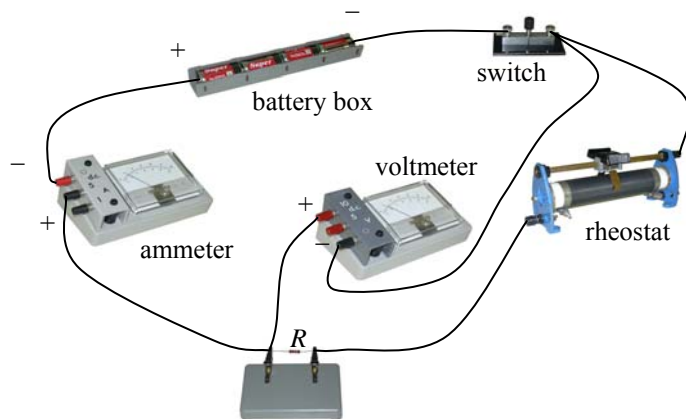

A student wants to measure the resistance of a resistor R and sets up the circuit shown. The student made which of these mistakes setting up the circuit ?

- (1) The polarity of the ammeter was reversed.
 - (2) The polarity of the voltmeter was reversed.
 - (3) The voltmeter was connected across both R and the rheostat.
- A. (1) only
 - B. (2) only
 - C. (1) and (3) only
 - D. (2) and (3) only

31.

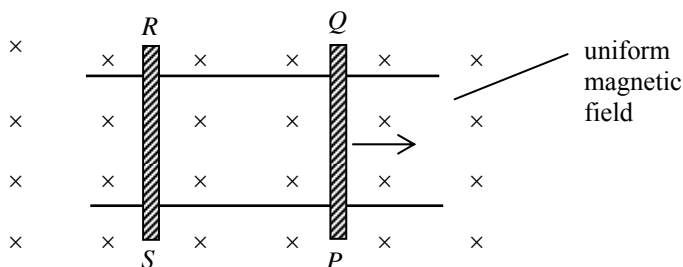

The figure shows conducting rods PQ and RS placed on two smooth, parallel, horizontal conducting rails. A uniform magnetic field is directed into the plane of the paper. PQ is given an initial velocity to the right and left to roll. Which statement is **INCORRECT** ?

- A. The induced current is in the direction $PQRS$.
- B. The magnetic force acting on rod PQ is towards the left.
- C. Rod RS starts moving towards the right.
- D. Rod PQ moves with a uniform speed.

32.

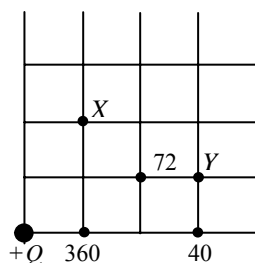

The figure shows the location of an isolated charge of size $+Q$. The size (in an arbitrary unit) of the electric field strength is marked at certain points. What is the size (in the same arbitrary unit) of the electric field strength at X and Y ?

- | | electric field strength at X | electric field strength at Y |
|----|--------------------------------|--------------------------------|
| A. | 72 | 30 |
| B. | 72 | 36 |
| C. | 90 | 30 |
| D. | 90 | 36 |

*33. Power is transmitted over long distances at high alternating voltages. Which statements are correct?

- (1) Alternating voltages can be stepped up or down efficiently by transformers.
- (2) For a given transmitted power, the current will be reduced if a high voltage is adopted.
- (3) The power loss in the transmission cables will be reduced if a high voltage is adopted.

- A. (1) and (2) only
- B. (1) and (3) only
- C. (2) and (3) only
- D. (1), (2) and (3)

34. Which of these is a nuclear fusion reaction ?

- A. ${}_{92}^{235}\text{U} + \text{n} \rightarrow {}_{56}^{144}\text{Ba} + {}_{36}^{90}\text{Kr} + 2\text{n}$
- B. ${}_{1}^2\text{H} + {}_{1}^3\text{H} \rightarrow {}_{2}^4\text{He} + \text{n}$
- C. ${}_{7}^{14}\text{N} + \text{n} \rightarrow {}_{6}^{14}\text{C} + {}_{1}^1\text{H}$
- D. ${}_{92}^{238}\text{U} \rightarrow {}_{90}^{234}\text{Th} + \alpha$

*35. On which of the following does the activity of a radioactive source depend ?

- (1) the nature of the nuclear radiation emitted by the source
- (2) the half-life of the source
- (3) the number of active nuclides in the source

- A. (1) only
- B. (3) only
- C. (1) and (2) only
- D. (2) and (3) only

36. Different absorbers are placed in turn between a radioactive source and a Geiger-Muller tube. Three readings are taken for each absorber. The following data are obtained:

Absorber	Count rate / s ⁻¹		
	–	200	205
paper	197	202	206
5 mm aluminium	112	108	111
25 mm lead	60	62	58
50 mm lead	34	36	34

What type(s) of radiation does the source emit ?

- A. β only
- B. γ only
- C. β and γ only
- D. α , β and γ

END OF SECTION A

List of data, formulae and relationships

Data

speed of light in vacuum	$c = 3.00 \times 10^8 \text{ m s}^{-1}$
acceleration due to gravity	$g = 9.81 \text{ m s}^{-2}$ (Close to the Earth)
universal gravitational constant	$G = 6.67 \times 10^{-11} \text{ N m}^2 \text{ kg}^{-2}$
charge of electron	$e = 1.60 \times 10^{-19} \text{ C}$
electron rest mass	$m_e = 9.11 \times 10^{-31} \text{ kg}$
permittivity of free space	$\epsilon_0 = 8.85 \times 10^{-12} \text{ C}^2 \text{ N}^{-1} \text{ m}^{-2}$
permeability of free space	$\mu_0 = 4\pi \times 10^{-7} \text{ H m}^{-1}$
Planck constant	$h = 6.63 \times 10^{-34} \text{ J s}$
molar gas constant	$R = 8.31 \text{ J K}^{-1} \text{ mol}^{-1}$
Stefan constant	$\sigma = 5.67 \times 10^{-8} \text{ W m}^{-2} \text{ K}^{-4}$
Avogadro constant	$N_A = 6.02 \times 10^{23} \text{ mol}^{-1}$
atomic mass unit	$u = 1.661 \times 10^{-27} \text{ kg}$
(1 u is equivalent to 931 MeV)	

Rectilinear motion

For uniformly accelerated motion :

$$v = u + at$$

$$s = ut + \frac{1}{2}at^2$$

$$v^2 = u^2 + 2as$$

Mathematics

Equation of a straight line $y = mx + c$

Arc length = $r\theta$

Surface area of cylinder = $2\pi rh + 2\pi r^2$

Volume of cylinder = $\pi r^2 h$

Surface area of sphere = $4\pi r^2$

Volume of sphere = $\frac{4}{3}\pi r^3$

For small angles, $\sin \theta \approx \tan \theta \approx \theta$ (in radians)

A1.	$E = mc \Delta T$	energy transfer during heating and cooling	D3.	$V = \frac{Q}{4\pi\epsilon_0 r}$	electric potential due to a point charge
A2.	$E = l \Delta m$	energy transfer during change of state	D4.	$E = \frac{V}{d}$	energy field between parallel plates (numerically)
A3.	$pV = nRT$	equation of state for an ideal gas	D5.	$I = nA\upsilon Q$	general current flow equation
A4.	$pV = \frac{1}{3} Nmc^2$	kinetic theory equation	D6.	$R = \frac{\rho l}{A}$	resistance and resistivity
A5.	$E_k = \frac{3RT}{2N_A}$	molecular kinetic energy	D7.	$R = R_1 + R_2$	resistors in series
B1.	$F = m \frac{\Delta v}{\Delta t} = \frac{\Delta p}{\Delta t}$	force	D8.	$\frac{1}{R} = \frac{1}{R_1} + \frac{1}{R_2}$	resistors in parallel
B2.	moment = $F \times d$	moment of a force	D9.	$P = IV = I^2 R$	power in a circuit
B3.	$E_p = mgh$	gravitational potential energy	D10.	$F = BQv \sin \theta$	force on a moving charge in a magnetic field
B4.	$E_k = \frac{1}{2} mv^2$	kinetic energy	D11.	$F = BIl \sin \theta$	force on a current-carrying conductor in a magnetic field
B5.	$F = kx$	Hooke's law	D12.	$V = \frac{BI}{nQt}$	Hall voltage
B6.	$P = Fv = \frac{W}{t}$	mechanical power	D13.	$B = \frac{\mu_0 I}{2\pi r}$	magnetic field due to a long straight wire
B7.	$a = \frac{v^2}{r} = \omega^2 r$	centripetal acceleration	D14.	$B = \frac{\mu_0 NI}{l}$	magnetic field inside a long solenoid
B8.	$F = \frac{Gm_1 m_2}{r^2}$	Newton's law of gravitation	D15.	$\epsilon = N \frac{\Delta \Phi}{\Delta t}$	induced e.m.f.
C1.	$\Delta y = \frac{\lambda D}{a}$	fringe width in double-slit interference	D16.	$\frac{V_s}{V_p} \approx \frac{N_s}{N_p}$	ratio of secondary voltage to primary voltage in a transformer
C2.	$d \sin \theta = n\lambda$	diffraction grating equation	E1.	$N = N_0 e^{-kt}$	law of radioactive decay
C3.	$\frac{1}{u} + \frac{1}{v} = \frac{1}{f}$	equation for a single lens	E2.	$t_{\frac{1}{2}} = \frac{\ln 2}{k}$	half-life and decay constant
D1.	$F = \frac{Q_1 Q_2}{4\pi\epsilon_0 r^2}$	Coulomb's law	E3.	$A = kN$	activity and the number of undecayed nuclei
D2.	$E = \frac{Q}{4\pi\epsilon_0 r^2}$	electric field strength due to a point charge	E4.	$E = mc^2$	mass-energy relationship

<p>Astronomy and Space Science</p> <p>$U = -\frac{GMm}{r}$ gravitational potential energy</p> <p>$P = \sigma AT^4$ Stefan's law</p> <p>$\frac{\Delta f}{f_0} \approx \frac{v}{c}$ Doppler effect</p>	<p>Energy and Energy Use</p> <p>$\frac{Q}{t} = k \frac{A(T_H - T_C)}{d}$ rate of energy transfer by conduction</p> <p>$U = \frac{k}{d}$ thermal transmittance U-value</p> <p>$P = \frac{1}{2} \rho A v^3$ maximum power by wind turbine</p>
<p>Atomic World</p> <p>$\frac{1}{2} m_e v_{\max}^2 = hf - \phi$ Einstein's photoelectric equation</p> <p>$E_n = -\frac{13.6}{n^2} \text{eV}$ energy level equation for hydrogen atom</p> <p>$\lambda = \frac{h}{p} = \frac{h}{mv}$ de Broglie formula</p> <p>$\theta \approx \frac{1.22\lambda}{d}$ Rayleigh criterion (resolving power)</p>	<p>Medical Physics</p> <p>$\theta = \frac{1.22\lambda}{d}$ Rayleigh criterion (resolving power)</p> <p>power = $\frac{1}{f}$ power of a lens</p> <p>$10 \log \frac{I}{I_0}$ intensity level (dB)</p> <p>$Z = \rho c$ acoustic impedance</p> <p>$\alpha = \frac{I_r}{I_0} = \frac{(Z_2 - Z_1)^2}{(Z_2 + Z_1)^2}$ intensity reflection coefficient</p> <p>$I = I_0 e^{-\mu x}$ transmitted intensity through a medium</p>

B

HONG KONG EXAMINATIONS AND ASSESSMENT AUTHORITY
HONG KONG DIPLOMA OF SECONDARY EDUCATION EXAMINATION

PHYSICS PAPER 1 (Sample Paper)

Section B : Question-Answer Book B

This paper must be answered in English

INSTRUCTIONS

- (1) Write your Candidate Number in the space provided on Page 1.
- (2) Stick barcode labels in the spaces provided on Pages 1, 3, 5, 7 and 9.
- (3) This section carries 84 marks. Answer **ALL** questions.
- (4) Write your answers in the spaces provided in this Question-Answer Book. Do not write in the margins. Answers written in the margins will not be marked.
- (5) Supplementary answer sheets will be provided on request. Write your Candidate Number, mark the question number box and stick a barcode label on each sheet. Tie them loosely but securely with a string **INSIDE** this Question-Answer Book.
- (6) The diagrams in this section are **NOT** necessarily drawn to scale.

Please stick the barcode label here.

Candidate Number

Question No.	Marker's Use Only	Examiner's Use Only
	Marker No.	Examiner No.
	Marks	Marks
1		
2		
3		
4		
5		
6		
7		
8		
9		
10		
11		
12		
13		
14		
Total		

Answer **ALL** questions. Parts marked with “*” involve knowledge of the extension component. Write your answers in the spaces provided.

1.

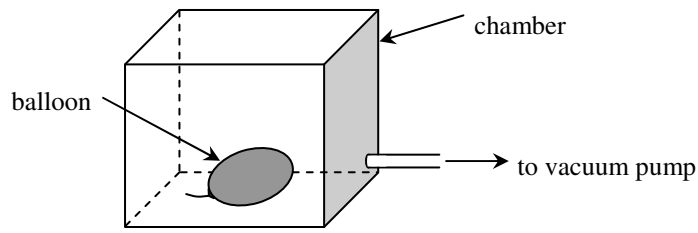

Figure 1.1

A balloon containing 0.01 m^3 of gas at a pressure of 100 kPa is placed inside a chamber. Air is slowly pumped out from the chamber while the temperature remains unchanged.

* (a) Explain, in terms of molecular motion, how the gas inside the balloon exerts a pressure on its inner surface. (2 marks)

.....

.....

.....

.....

* (b) Find the final pressure inside the balloon when its volume is doubled. (2 marks)

.....

.....

.....

.....

* (c) Sketch a graph to show the relationship between the pressure p inside the balloon and the volume V of the balloon. (2 marks)

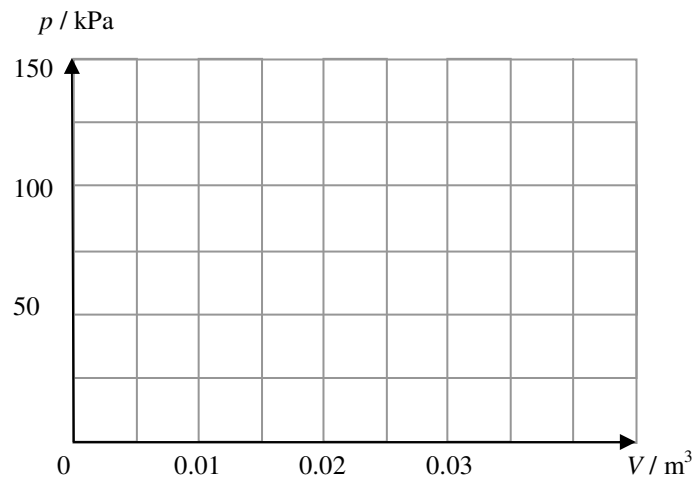

Answers written in the margins will not be marked.

Answers written in the margins will not be marked.

Answers written in the margins will not be marked.

2.

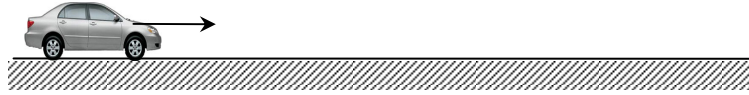

Figure 2.1

In a road test, John drives his car along a straight horizontal road (see Figure 2.1). The car takes 9.3 s to accelerate from rest to 100 km h^{-1} . The total mass of John and his car is 1400 kg. (Note: $100 \text{ km h}^{-1} = 27.8 \text{ m s}^{-1}$)

- (a) Find the total kinetic energy of John and his car when travelling at 100 km h^{-1} . Hence estimate the average output power of the car during this acceleration. (3 marks)

.....

.....

.....

.....

.....

.....

.....

.....

.....

- (b) A similar road test is conducted on an inclined road. The car now takes more than 9.3 s to accelerate from rest to 100 km h^{-1} along the road (see Figure 2.2). Assume the output power of the car remains unchanged. Explain why it takes a longer time for the car to accelerate up an inclined road than along a horizontal road. (2 marks)

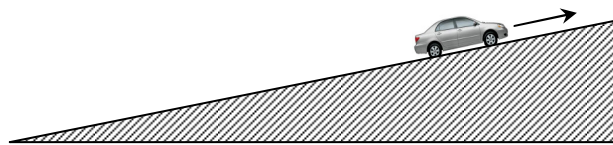

Figure 2.2

.....

.....

.....

.....

.....

Answers written in the margins will not be marked.

Answers written in the margins will not be marked.

Answers written in the margins will not be marked.

3. A ball is kicked and moves with an initial velocity of 10 m s^{-1} at an angle of 40° to the horizontal. The ball then just passes a block of height 1.6 m , reaching the highest point D , and finally hits the ground at E , as shown in Figure 3.1. (Neglect air resistance and the size of the ball.)

Figure 3.1

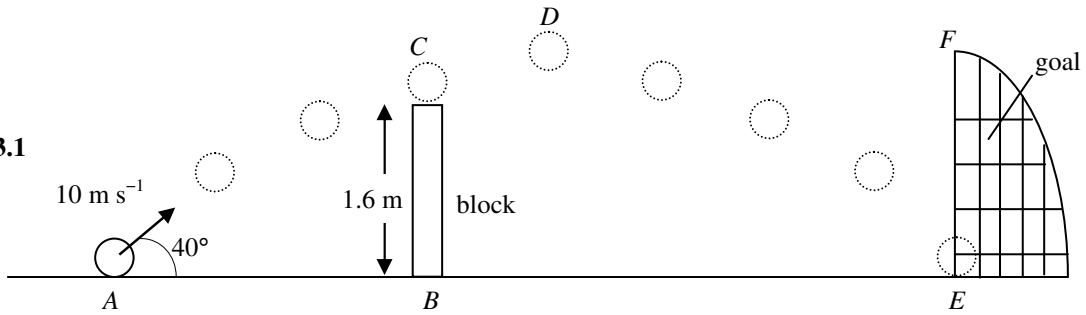

- (a) Draw an arrow to indicate the direction of acceleration of the ball at C. (1 mark)
- * (b) For a projectile of initial velocity u that makes an angle θ with the horizontal, show that its horizontal range is given by $\frac{u^2 \sin 2\theta}{g}$. Hence, or otherwise, find another angle of projection such that the ball can still reach E with the same initial speed of 10 m s^{-1} . (Given: $2 \sin \theta \cos \theta = \sin 2\theta$) (4 marks)

Answers written in the margins will not be marked.

Answers written in the margins will not be marked.

.....

.....

.....

.....

.....

.....

.....

.....

.....

.....

.....

.....

.....

.....

.....

.....

- (c) Calculate the speed of the ball at C. (2 marks)

.....

.....

.....

.....

.....

.....

.....

.....

Answers written in the margins will not be marked.

Please stick the barcode here.

4. One end of a piece of string is fixed to a wall. A wave pulse travels along the string at a speed of 0.5 m s^{-1} towards the fixed end. Figure 4.1 shows the string at time $t = 0 \text{ s}$ and $t = 2 \text{ s}$.

Figure 4.1

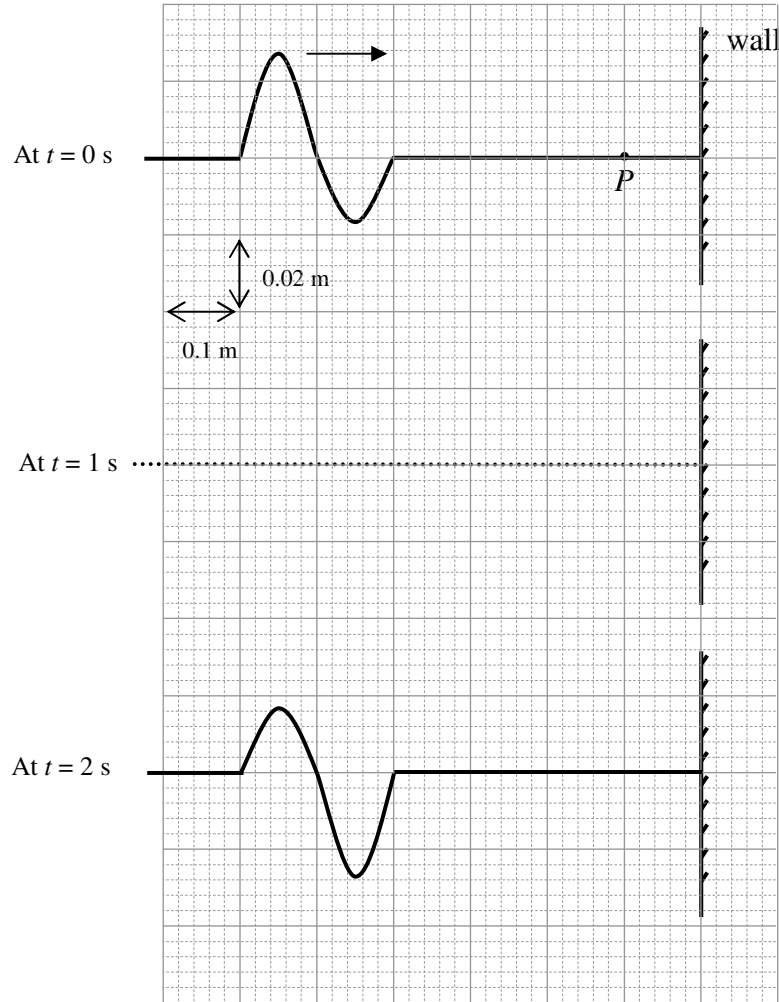

Answers written in the margins will not be marked.

Answers written in the margins will not be marked.

- (a) On Figure 4.1, draw the shape of the wave pulse at $t = 1 \text{ s}$. (1 mark)
- (b) Sketch a graph of the displacement of point P on the string at a distance of 0.1 m from the wall during the period $t = 0 \text{ s}$ to $t = 1 \text{ s}$. (2 marks)

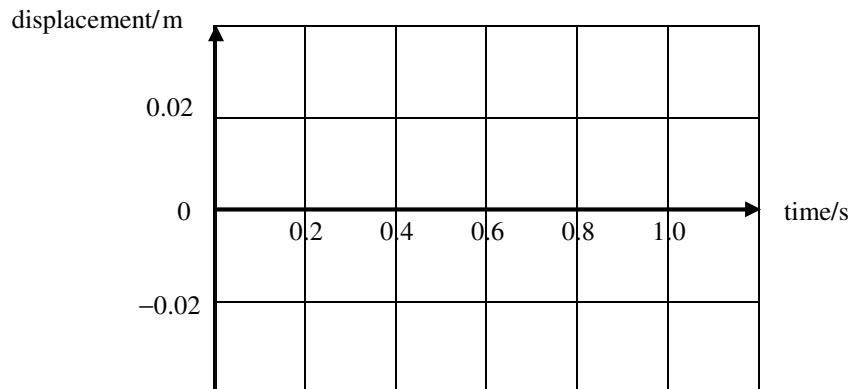

Answers written in the margins will not be marked.

5.

Figure 5.1

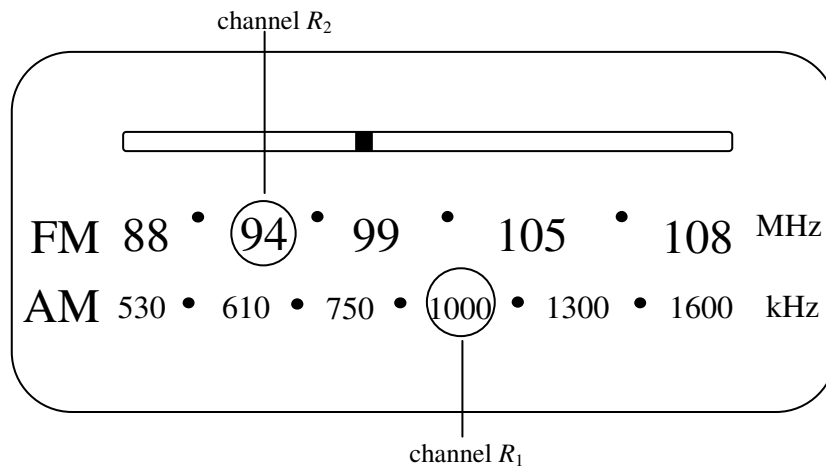

Figure 5.1 shows the display panel of a radio and the broadcasting frequencies of two radio channels R_1 and R_2 . Given : speed of electromagnetic waves = $3.00 \times 10^8 \text{ m s}^{-1}$

- (a) Find the wavelength of the radio waves used by channel R_1 . (1 mark)

.....

.....

.....

.....

- (b) Anita's house is surrounded by hills and at her house, the reception of one of the two radio channels is better. For which radio channel is the reception better? Explain your answer. (2 marks)

.....

.....

.....

.....

Answers written in the margins will not be marked.

Answers written in the margins will not be marked.

Answers written in the margins will not be marked

6.

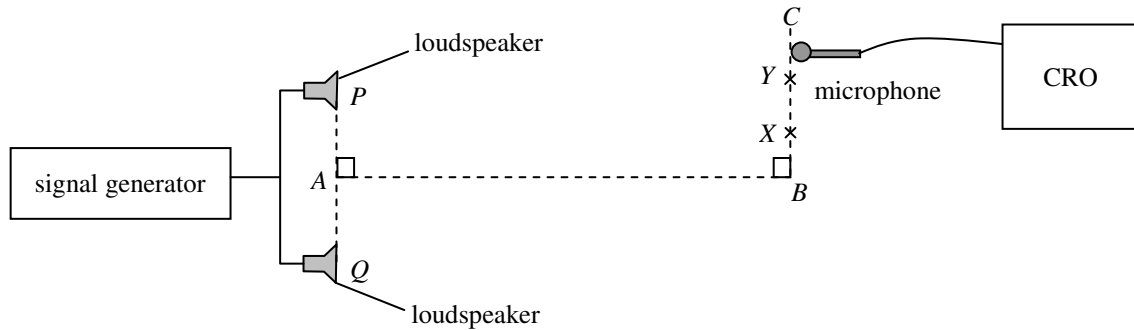

Figure 6.1

Figure 6.1 shows two identical loudspeakers P and Q are connected to a signal generator. Position A is the mid-point of PQ . A microphone connected to a CRO is moved along BC . The amplitude of the CRO trace increases as the loudness of the sound detected increases. Figure 6.2 shows how the amplitude of the CRO trace varies with the position of the microphone.

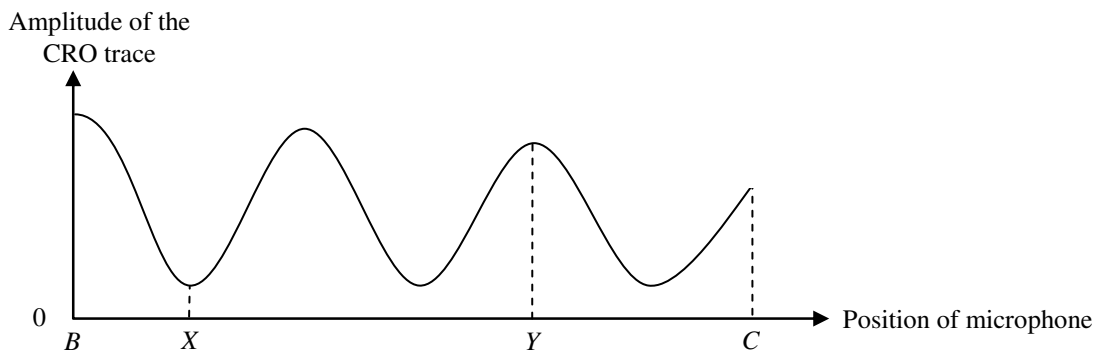

Figure 6.2

(a) (i) Explain why the loudness of the sound varies along BC . (2 marks)

.....

.....

.....

(ii) State ONE reason why the amplitude of the CRO trace is NOT zero at position X . (1 mark)

.....

.....

(b) If $PY = 5.10$ m and $QY = 5.78$ m, find the wavelength of the sound. (2 marks)

.....

.....

.....

Answers written in the margins will not be marked.

Answers written in the margins will not be marked.

Answers written in the margins will not be marked

7. Amy uses the motor of a toy fan as a simple generator. She connects a bulb to the two terminals of the motor. This is shown in Figure 7.1.

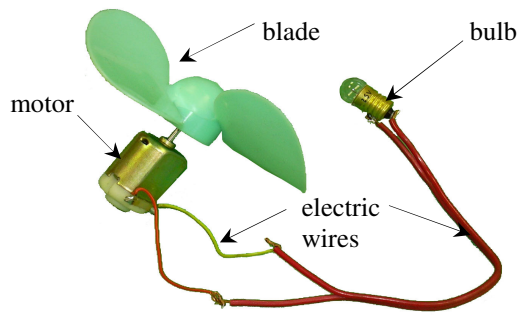

Figure 7.1

The bulb lights up when the blades are turned rapidly. Explain why and state the energy conversion taking place in this process. (4 marks)

.....

.....

.....

.....

.....

.....

.....

.....

Answers written in the margins will not be marked.

Answers written in the margins will not be marked.

Answers written in the margins will not be marked.

8. Figure 8.1 shows an earth leakage circuit breaker (漏電斷路器) installed in a domestic circuit. The live and the neutral wires pass through the centre of a soft iron ring of mean radius 1 cm. A 100-turn coil C with cross-section area 0.8 cm^2 is wound on the ring.

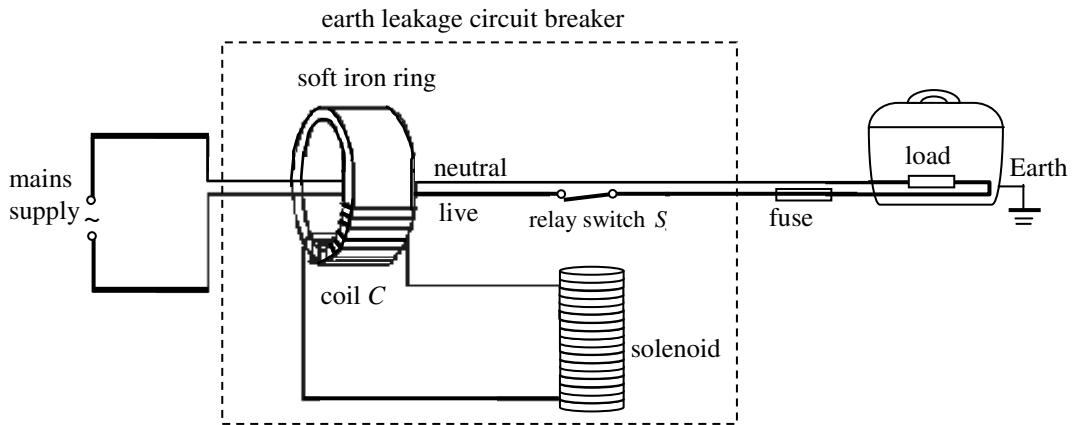

Figure 8.1

In case of an earth leakage in the domestic circuit such that the current in the neutral wire and the live wire differ by 0.5 A or more, the relay switch S opens and disconnects the mains supply. To reconnect the supply, S has to be reset manually.

- (a) Explain why S opens when there is a leakage current of 0.5 A from the load to the Earth. (3 marks)

.....

.....

.....

.....

.....

.....

.....

.....

.....

.....

Answers written in the margins will not be marked.

Answers written in the margins will not be marked.

Answers written in the margins will not be marked

- (b) Calculate the magnetic field B through coil C when there is a leakage current of 0.5 A from a live wire to the Earth. The magnetic field B due to a current-carrying conductor is 1500 times that in soft iron. (2 marks)

.....

.....

.....

.....

.....

.....

.....

.....

- (c) Electrical appliances are usually equipped with fuses. When a short circuit occurs between the live and neutral wires, the fuse blows but the earth leakage circuit breaker does not operate. Explain these observations. (2 marks)

.....

.....

.....

.....

.....

.....

.....

.....

Answers written in the margins will not be marked.

Answers written in the margins will not be marked.

Answers written in the margins will not be marked

9.



Figure 9.1

Figure 9.1 shows a microwave oven. Mary wants to estimate the useful output power of the oven. She is provided with the apparatus and material shown in Figure 9.2.

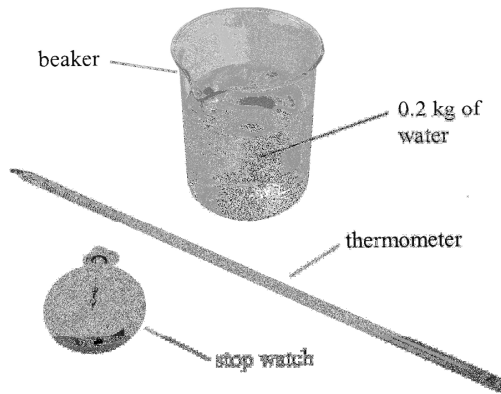

Figure 9.2

- (a) Describe how Mary should conduct the experiment. Specify all measurements Mary has to take. State **EITHER** one precaution taken **OR** one assumption made when conducting this experiment. Write down an equation for calculating the useful output power. (5 marks)

.....

.....

.....

.....

.....

.....

.....

.....

.....

Answers written in the margins will not be marked.

Answers written in the margins will not be marked.

Answers written in the margins will not be marked.

- (b) The value obtained by Mary is found to be smaller than the rated power of the oven. Give one possible reason to account for this difference.

.....

.....

.....

.....

.....

- (c) Explain whether increasing the mass of water used in the experiment would improve the accuracy of the experiment. (1 mark)

.....

.....

.....

.....

.....

Answers written in the margins will not be marked.

Answers written in the margins will not be marked.

Answers written in the margins will not be marked.

10.

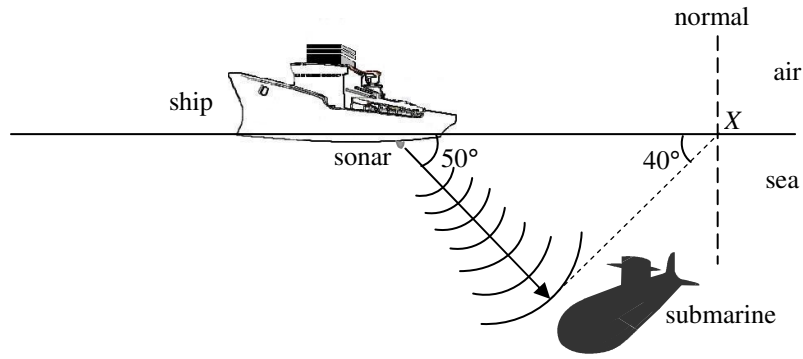

Figure 10.1

Figure 10.1 shows a ship equipped with sonar. The sonar emits ultrasonic waves of frequency 25 kHz into the sea. The waves propagate at an angle of 50° to the surface of the sea and are reflected from a submarine back to the ship after 0.15 s.

Given : speed of sound in air = 340 m s⁻¹
 speed of sound in sea water = 1500 m s⁻¹

- (a) Calculate the vertical distance of the submarine beneath the sea surface. (2 marks)

.....

.....

.....

.....

.....

- (b) Some of the reflected waves propagate along the dotted line and emerge into the air at X. Calculate the angle of refraction in air. (2 marks)

.....

.....

.....

.....

.....

- (c) Is it possible for ultrasonic waves, at certain angles of incidence, to undergo total internal reflection when they go from sea water to the air? Explain. (2 marks)

.....

.....

.....

.....

.....

Answers written in the margins will not be marked.

Answers written in the margins will not be marked.

Answers written in the margins will not be marked

11. (a) A spacecraft with an astronaut on board is launched on a rocket. The rocket with the spacecraft has an initial mass of 4.80×10^5 kg at take-off. The rocket engine expels hot exhaust gas at a constant speed of 2600 m s^{-1} downwards relative to the rocket. Assume that 1.15×10^3 kg of gas is expelled in the first 0.5 s. (Neglect air resistance.)

(i) Calculate the average thrust (the upward force) acting on the rocket due to the exhaust gas during the first 0.5 s. (2 marks)

.....

.....

.....

.....

.....

.....

.....

.....

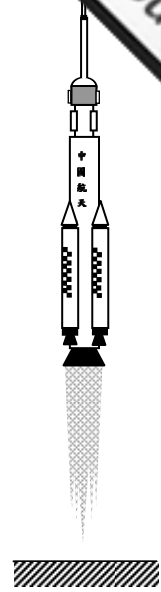

Figure 11.1

(ii) On Figure 11.1, draw and label an arrow for each force acting on the rocket. Assuming that the change in mass of the rocket during the first 0.5 s is negligible, estimate the acceleration of the rocket. (3 marks)

.....

.....

.....

.....

.....

.....

.....

.....

Answers written in the margins will not be marked.

Answers written in the margins will not be marked.

Answers written in the margins will not be marked

(b) The spacecraft of mass 7.80×10^3 kg now enters a circular orbit of radius r around the Earth.

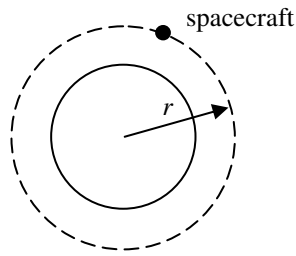

Figure 11.2

* (i) Show that the speed of the spacecraft in the orbit is given by $\sqrt{\frac{g}{r}} R_E$ where R_E is the radius of the Earth. (2 marks)

.....

.....

.....

.....

.....

.....

.....

.....

.....

.....

* (ii) How long does it take for the spacecraft to orbit the Earth 14 times ? (3 marks)
 Given : radius of the orbit $r = 6.71 \times 10^6$ m
 radius of the Earth $R_E = 6.37 \times 10^6$ m

.....

.....

.....

.....

.....

.....

.....

.....

.....

.....

(c) Give ONE reason why an aircraft is unable to fly in space like a rocket. (1 mark)

.....

.....

Answers written in the margins will not be marked.

Answers written in the margins will not be marked.

Answers written in the margins will not be marked

12.



Figure 12.1

Iris uses the apparatus shown in Figure 12.1 to study the lifetime of AA-size cells when used to power a bulb. She connects a cell and a switch to the bulb and uses a voltage sensor to measure the voltage across the bulb.

- (a) Draw a circuit diagram to illustrate how the apparatus is connected. Use the symbol V to denote the voltage sensor and the data-logger. (2 marks)

- (b) Iris conducts the experiment with a zinc-carbon cell, an alkaline cell and a lithium cell separately. Figure 12.2 shows the variation of the voltage across the bulb with time for the cells. The bulb lights up as long as the voltage across it is above 0.6 V.

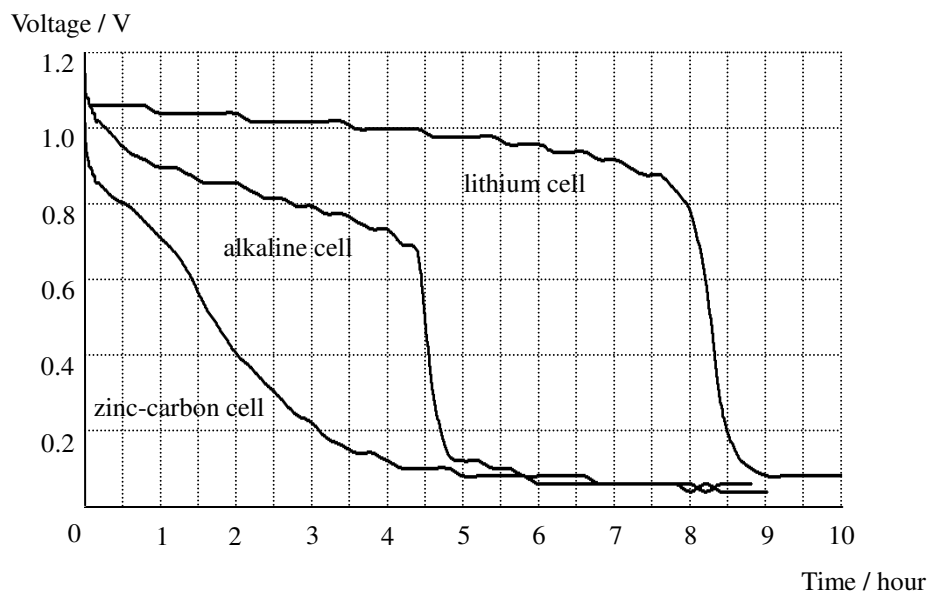

Figure 12.2

Answers written in the margins will not be marked.

Answers written in the margins will not be marked.

Answers written in the margins will not be marked.

- (b) (i) A salesman claims that the lifetime of a lithium cell for lighting up the bulb is 10 times that of an alkaline cell. Determine whether the claim is correct or not. (2 marks)

.....

.....

.....

.....

.....

.....

- (ii) Table 12.3 shows the prices of the three types of cell.

Type of cells	Price per cell
zinc-carbon	\$ 1.5
alkaline	\$ 3.8
lithium	\$25.0

Table 12.3

Which type of cells is the best buy, in terms of the cost per hour for lighting up the bulb ? Show your calculations. (3 marks)

.....

.....

.....

.....

.....

.....

.....

.....

Answers written in the margins will not be marked.

Answers written in the margins will not be marked.

Answers written in the margins will not be marked

13. Josephine conducts an investigation on transformers. Primary and secondary coils are wound on soft-iron C-cores to form a transformer. She sets up a circuit as shown in Figure 13.1.

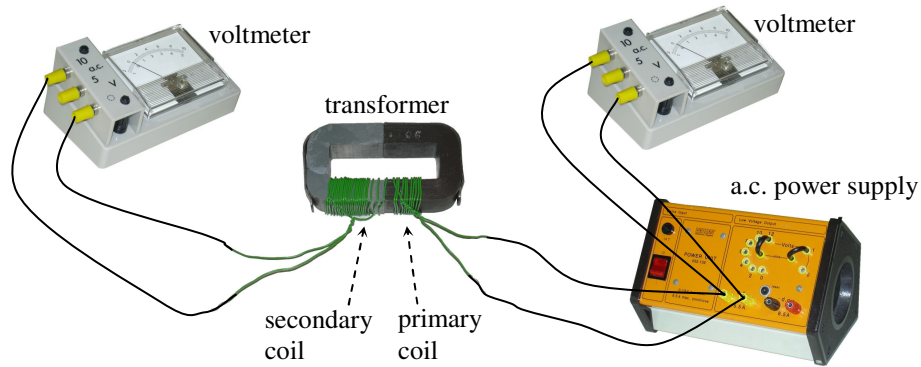

Figure 13.1

*(a) Josephine varies the input voltage V_1 to the transformer and records the corresponding output voltage V_2 . The results are shown in Table 13.2. Figure 13.3 shows the graph of V_2 against V_1 . Draw a conclusion for this investigation.

V_1 / V	V_2 / V
1.5	2.5
3.0	5.1
4.5	7.6
6.0	10.0

Table 13.2

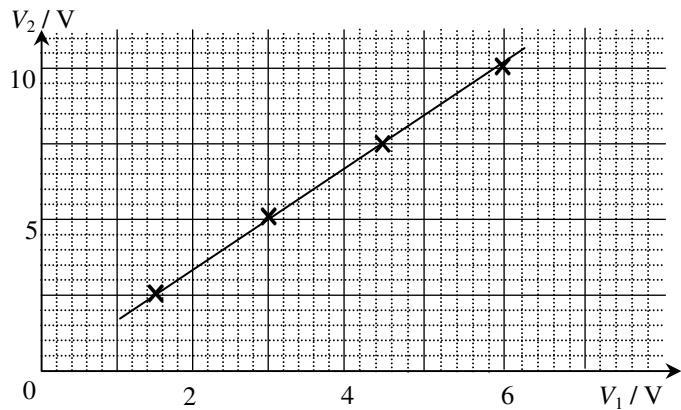

Figure 13.3

(1 mark)

Answers written in the margins will not be marked.

Answers written in the margins will not be marked.

.....

.....

.....

.....

*(b) Deduce the value of V_2 that will be produced when V_1 equals 8.0 V. (1 mark)

.....

.....

.....

.....

Answers written in the margins will not be marked.

*(c) Josephine wants to study the relationship between the output voltage and the number of turns in the secondary coil of the transformer. Describe how she can conduct the experiment. (2 marks)

.....

.....

.....

.....

.....

.....

*(d) Josephine adds a bulb to the circuit as shown in Figure 13.4. Suggest how Josephine can estimate the efficiency of the transformer. State the measurement(s) she must take. Additional apparatus may be used if necessary. (3 marks)

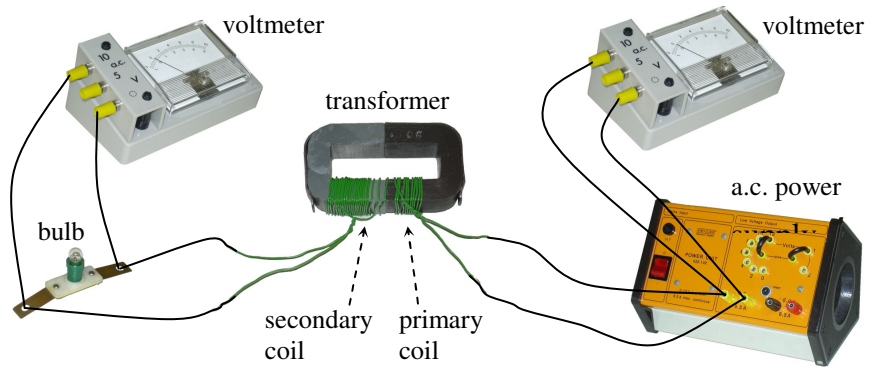

Figure 13.4

.....

.....

.....

.....

.....

.....

Answers written in the margins will not be marked.

Answers written in the margins will not be marked.

Answers written in the margins will not be marked

14. In April 1986, a disastrous nuclear accident happened at the Chernobyl Nuclear Power Station. quantity of various radioactive substances was released and spread to neighbouring countries. radiation levels recorded in these countries were much higher than the normal background count rate.

(a) State **ONE** source of background radiation. (1 mark)

(b) One of the radioactive isotopes released in the accident was caesium-137 (Cs-137). The following equation shows how Cs-137 is produced :

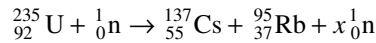

Given : mass of one nuclide of ${}_{92}^{235}\text{U} = 235.0439 \text{ u}$
 ${}_{55}^{137}\text{Cs} = 136.9071 \text{ u}$
 ${}_{37}^{95}\text{Rb} = 94.9399 \text{ u}$
 ${}_0^1\text{n} = 1.0087 \text{ u}$

1 u is equivalent to 931 MeV

(i) What is the value of x ? (1 mark)

*(ii) Find the energy release in the fission of one U-235 nuclide in MeV. (2 marks)

*(iii) The half-life of Cs-137 is 30 years. A soil sample contaminated by Cs-137 has an activity of $1.2 \times 10^6 \text{ Bq}$ (disintegrations per second). A physicist comments that the contaminated sample will affect the environment for more than 350 years. Justify the physicist's claim with calculations. It is known that the activity of an uncontaminated soil sample is 200 Bq. (2 marks)

END OF PAPER

Answers written in the margins will not be marked.

Answers written in the margins will not be marked.

Answers written in the margins will not be marked