

HONG KONG EXAMINATIONS AND ASSESSMENT AUTHORITY
HONG KONG DIPLOMA OF SECONDARY EDUCATION EXAMINATION

DESIGN AND APPLIED TECHNOLOGY PAPER 2A
Automation

SAMPLE PAPER

Time allowed: 1 hour
This paper must be answered in English

Candidates are required to attempt any **TWO** questions.

Write all answers in the answer book.

Not to be taken away before the
end of the examination session

1. Figure 1 shows a traffic light control system, including the names and representational symbols of its component parts. The system operates in typical repeated cycles, and the controller of the system determines a sequence of operation as shown in Table 1.

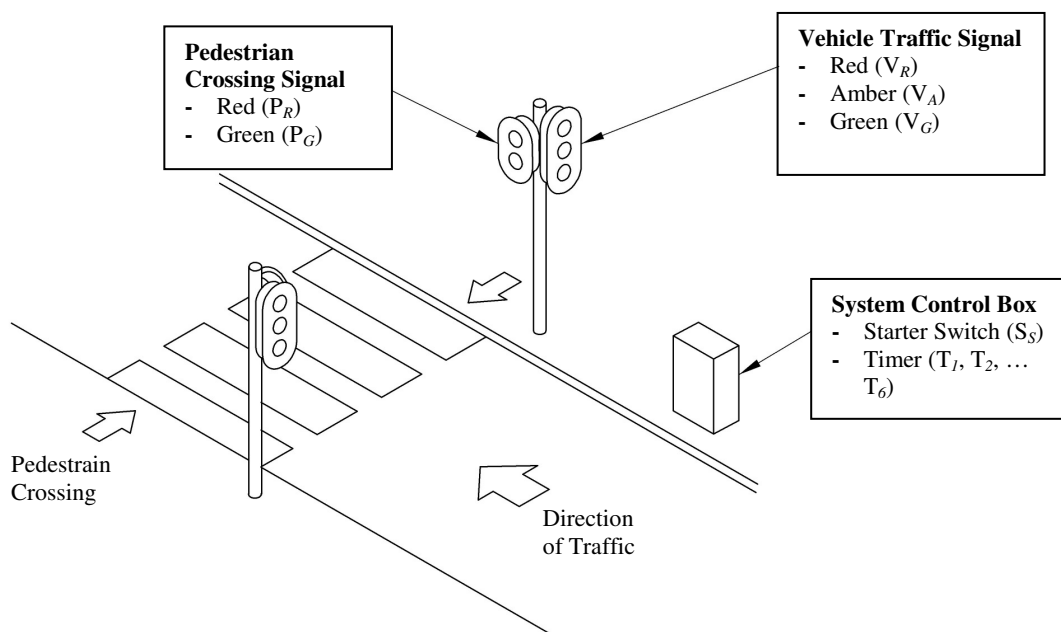

Figure 1

Operation Sequence (For one complete cycle)

- (1) When the 'Starter Switch' is ON ($S_S=1$), the 'Vehicle Traffic Signal (Green)' turns ON ($V_G=1$) and the 'Pedestrian Crossing Signal (Red)' turns ON ($P_R=1$), indicating that only vehicles can GO and pedestrians should STOP.
- (2) After 35 seconds ($T_1=35s$), the 'Vehicle Traffic Signal (Green)' turns OFF ($V_G=0$) and the 'Vehicle Traffic Signal (Amber)' turns ON ($V_A=1$).
- (3) After 10 seconds ($T_2=10s$), the 'Vehicle Traffic Signal (Amber)' turns OFF ($V_A=0$) and the 'Vehicle Traffic Signal (Red)' turns ON ($V_R=1$), indicating that vehicles should STOP.
- (4) After 5 seconds ($T_3=5s$), the 'Pedestrian Crossing Signal (Red)' turns OFF ($P_R=0$), and the 'Pedestrian Crossing Signal (Green)' turns ON ($P_G=1$), indicating that pedestrians can CROSS.
- (5) After 15 seconds ($T_4=15s$), the 'Pedestrian Crossing Signal (Green)' blinks 5 times ($P_G=0, 1, 0, 1, 0, 1, 0, 1, 0, 1$) within 10 seconds ($T_5=10s$) indicating that pedestrian crossing time will end soon.
- (6) The 'Pedestrian Crossing Signal (Green)' turns OFF ($P_G=0$), and the 'Pedestrian Crossing Signal (Red)' turns ON ($P_R=1$), pedestrians should STOP. The 'Vehicle Traffic Signal (Amber)' turns ON ($V_A=1$), while the 'Vehicle Traffic Signal (Red)' stays ON.
- (7) After 5 seconds ($T_6=5s$), the 'Vehicle Traffic Signal (Red)' turns OFF and the 'Vehicle Traffic Signal (Amber)' also turns OFF ($V_R=0, V_A=0$), then 'Vehicle Traffic Signal (Green)' turns ON ($V_G=1$), indicating that vehicles can GO and pedestrians should STOP.

Table 1

- (a) Based on the above operation sequence, copy and complete the following ‘Condition’ table in the answer book:

| Sequence | Required Condition | Output Status |
|----------|------------------------|------------------------|
| 1 | $S_5=1$ or $T_6(5s)=1$ | $V_G, P_R; (T_1)$ |
| 2 | | |
| 3 | | |
| 4 | | |
| 5 | | |
| 6 | $T_5(10s)=1$ | $V_R, V_A, P_R; (T_6)$ |

(8 marks)

- (b) Based on the above operation sequence, draw the ‘Timing Diagram’ of the traffic light control system with annotation. (12 marks)
- (c) Using an annotated sketch, suggest an intelligent technology to enable the traffic control system as shown in Figure 1 to adapt to real-time traffic conditions. (5 marks)

2. Figure 2(a) shows a washing machine.

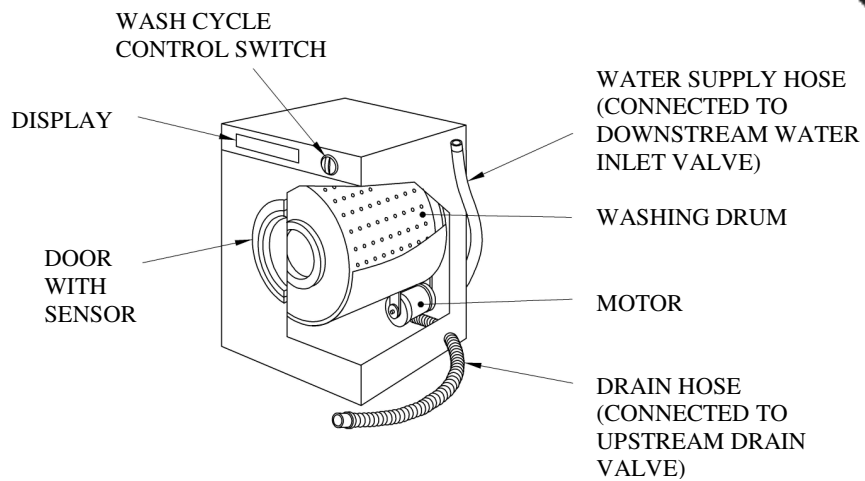

Figure 2(a)

To wash clothes, you first load clothes into the drum of the washing machine, and set manually the wash and rinse cycles on the control panel.

(a) Suggest two sensors / devices for ensuring the safe and easy operation of the washing machine, and state the function of each sensor / device. (6 marks)

(b) Copy and complete the control system diagram of the washing machine as shown in Figure 2(b) into the answer book, including the sensors / devices that you have suggested in (a). (5 marks)

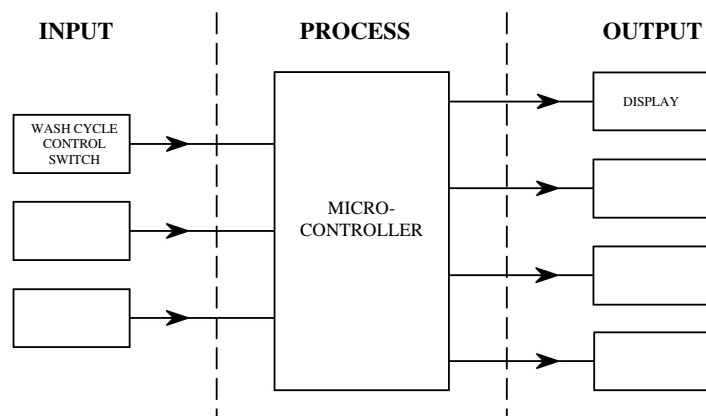

Figure 2(b)

- (c) Figure 2(c) shows the logic circuit for controlling the electric motor of a washing machine. The electric motor can only be started by activating all the following three components: Sensor 'A', Sensor 'B', and mechanical switch 'C'. Copy and complete the 'truth table' as shown in Figure 2(d) below into the answer book. (4 marks)

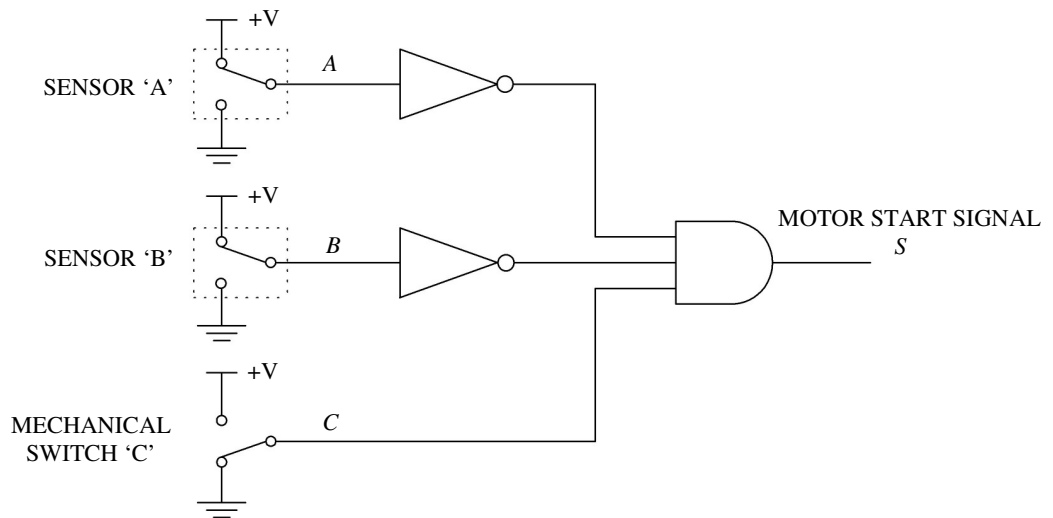

Figure 2(c)

| A | B | C | \bar{A} | \bar{B} | S |
|-----|-----|-----|-----------|-----------|-----|
| 0 | 0 | 0 | | | |
| 0 | 0 | 1 | | | |
| 0 | 1 | 0 | | | |
| 0 | 1 | 1 | | | |
| 1 | 0 | 0 | | | |
| 1 | 0 | 1 | | | |
| 1 | 1 | 0 | | | |
| 1 | 1 | 1 | | | |

Figure 2(d)

- (d) (i) Using annotated schematic diagrams, briefly explain the operating principle of a 'stepper motor' or a 'servo motor' in motion control. (6 marks)
- (ii) Suggest one advantage and one disadvantage of each type of motor. (4 marks)

3. (a) Figure 3(a) shows part of an automatic bottle filling line. Empty bottles are uniformly spaced on a conveyor belt. The filling tube is preset to discharge a certain amount of liquid into a positioned bottle.

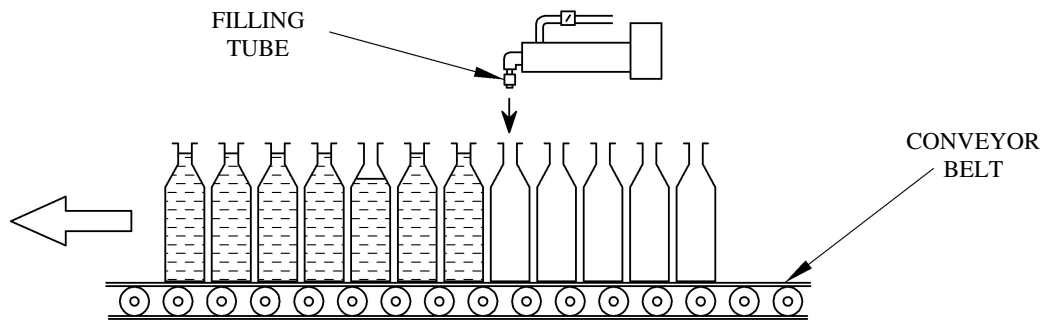

Figure 3(a)

- (i) Design an automatic 'inspection sub-system' to detect whether each filled bottle is being charged to the preset level. The inspection sub-system can output an electric signal to activate a pneumatic 'rejecting device' to divert bottles not being filled to the preset level for reworking.

With the aid of an annotated sketch, describe briefly the working principles of the inspection sub-system and the rejecting device. (10 marks)

- (ii) Referring to the rejecting device you have suggested in (a) (i), draw a pneumatic circuit diagram of the device using symbols given in Figure 3(b) below. (Each symbol can be used once, more than once, or not at all.) (5 marks)

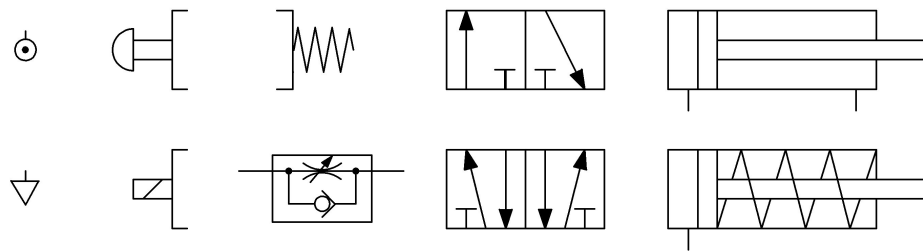

Figure 3(b)

(b) Figure 3(c) shows two common configurations of robot arms.

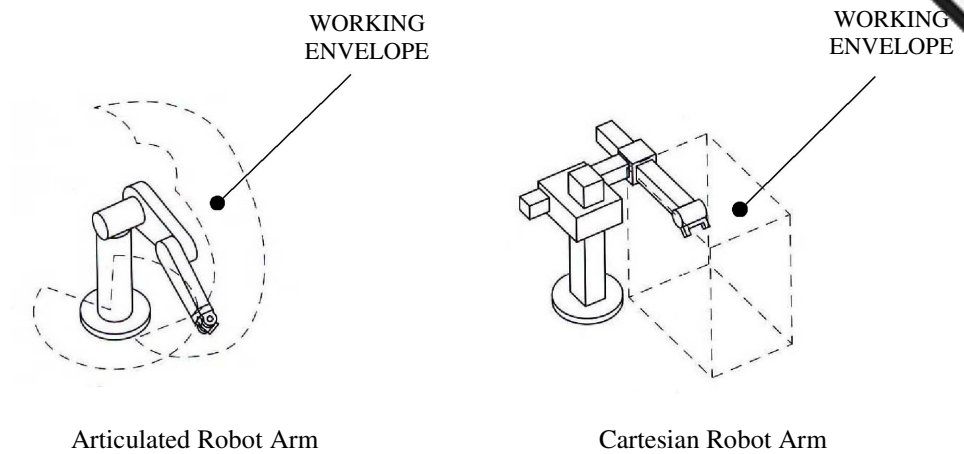

Figure 3(c)

- (i) Using annotated sketches, show how each robot arm configuration can be applied in an automated production process. (6 marks)
- (ii) Suggest one other situation appropriate for using robots. Give a reason to support your answer. (4 marks)

END OF PAPER

HONG KONG EXAMINATIONS AND ASSESSMENT AUTHORITY
HONG KONG DIPLOMA OF SECONDARY EDUCATION EXAMINATION

StudentBounty.com

DESIGN AND APPLIED TECHNOLOGY PAPER 2B
Creative Digital Media

SAMPLE PAPER

Time allowed: 1 hour
This paper must be answered in English

Candidates are required to attempt any **TWO** questions.

Write all answers in the answer book.

Not to be taken away before the
end of the examination session

1. (a) Explain the terms ‘denotation’ and ‘connotation’ with regard to media literacy. Give an example to illustrate each of the terms. (6 marks)
- (b) Explain the difference between ‘connotation’ and ‘myth’. (4 marks)
- (c) Referring to Figure 1, make two observations about each of the following:
 - (i) the visual composition of the picture; (4 marks)
 - (ii) the applications of the basic principles of communication. (4 marks)

Give one reason to support each of your observations. (4 marks)



Source: Beuys, J. (1970), ‘Filz-TV’, in Frieling, R. & Herzogenrath, W. (2006), 40 Years Videoart.de: Digital Heritage: Video Art in Germany from 1963 to the Present. Ostfildern, Germany: Hatje Cantz Publishers.

Figure 1

- (d) Referring to Figure 1, describe briefly the message that the picture is conveying. (3 marks)

2. Design a logo for a campaign to promote the idea of 'Pets should not be abandoned'. The logo is suitable for use with digital media:
- (a) Illustrate your design with an annotated colour sketch and explain the design concept behind it. (13 marks)
 - (b) Referring to your design in (a), explain the meaning of the terms 'signifier' and 'signified' with regard to media literacy. (6 marks)
 - (c) State three factors that you should consider when the logo is to be used in the printed format. (6 marks)
3. (a) Design and sketch a storyboard for a 3-minute video on the topic 'Sports Day of My School' onto the given templates. (12 marks)
- (b) Referring to your answer in (a), explain the workflow of digital video editing with a block diagram. (5 marks)
- (c) With regard to techniques in video editing, illustrate with annotated sketches the differences between the following video editing techniques:
- (i) 'roll editing' and 'ripple editing';
 - (ii) 'slip editing' and 'slide editing'. (6 marks)
- (d) With regard to techniques in video editing, describe one method of hiding an edit point. (2 marks)

END OF PAPER

HONG KONG EXAMINATIONS AND ASSESSMENT AUTHORITY
HONG KONG DIPLOMA OF SECONDARY EDUCATION EXAMINATION

StudentBounty.com

DESIGN AND APPLIED TECHNOLOGY PAPER 2C
Design Implementation and Material Processing

SAMPLE PAPER

1 hour

This paper must be answered in English

Candidates are required to attempt any **TWO** questions.

Complete all answers in the answer book.

Not to be taken away before the
end of the examination session

1. Figure 1 shows a 'plastic coding' on the bottom of a plastic bottle.

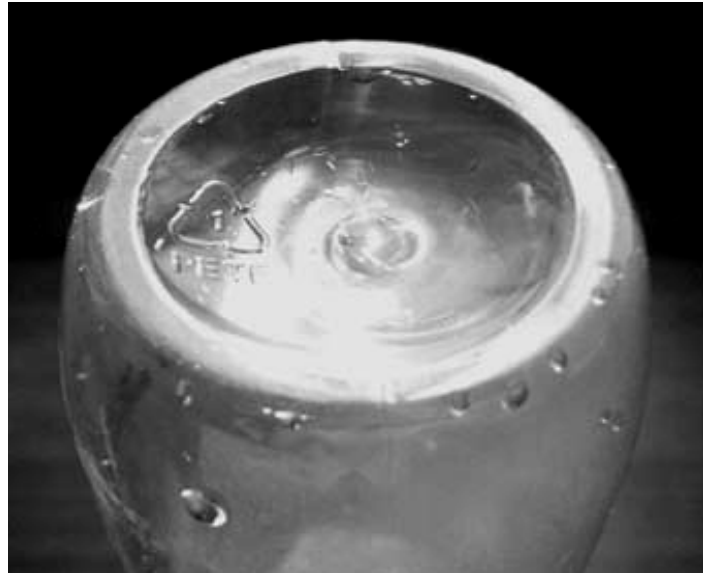
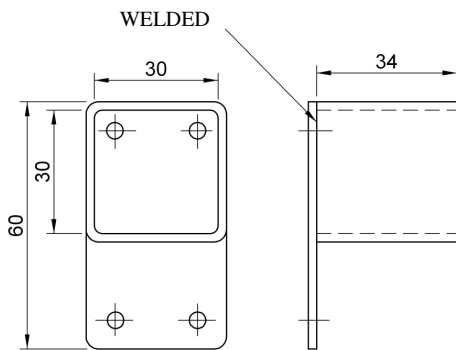

Figure 1

- (a) (i) Give one reason for putting the symbol on the plastic bottle.
(ii) State the name of the material represented by the symbol.
(iii) Give one property of the material that you have given in (a) (ii). (6 marks)
- (b) Using a flow diagram, show the main stages of recycling plastic waste, starting with the stage of 'separate plastics by type' and ending with the stage of 'mould into recycled plastic products'. (4 marks)
- (c) Using annotated sketches, show the mass production process for producing plastic bottles. (5 marks)
- (d) Suggest two products that could be made from recycled materials. (2 marks)
- (e) To minimise waste, it is desirable that products are designed with the four R's (Reduce, Reuse, Recover, and Recycle) in mind. Discuss how product designers can minimise waste using each of the four R's. (8 marks)

2. Figure 2(a) shows the preliminary design of a bracket. The bracket is to be mounted on to a wall with screws for holding a square tube as shown in Figure 2(b).



Note:

1. Dimensions given are for reference only.
2. Thickness of the bracket may vary from 2 to 3 mm depending on the material chosen.

Figure 2(a)

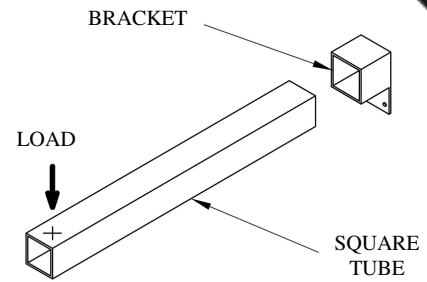

Note:

1. Size of square tube: 30 × 30 × 300 mm.
2. Details of fastening method not shown.

Figure 2(b)

- (a) If mild steel is selected as the material for making a prototype of the bracket, state four major processes involved. (4 marks)
- (b) If 100 000 brackets as shown in Figure 2(a) are required,
 - (i) using annotated sketches, describe briefly the major production process; (5 marks)
 - (ii) state a suitable metal for production. (1 mark)
- (c) With the aid of an annotated sketch, illustrate a temporary method of fixing the square tube to the bracket. (4 marks)
- (d) With the aid of a 'stress-strain diagram', explain the behaviour of the bracket material that you have suggested in (b) if the applied load in Figure 2(b) exceeded its yield point for a few minutes. (6 marks)
- (e) State five considerations when redesigning this bracket for improvement purpose. (5 marks)

3. Figure 3 shows a typical layout of a Computer Integrated Manufacture (CIM) system.

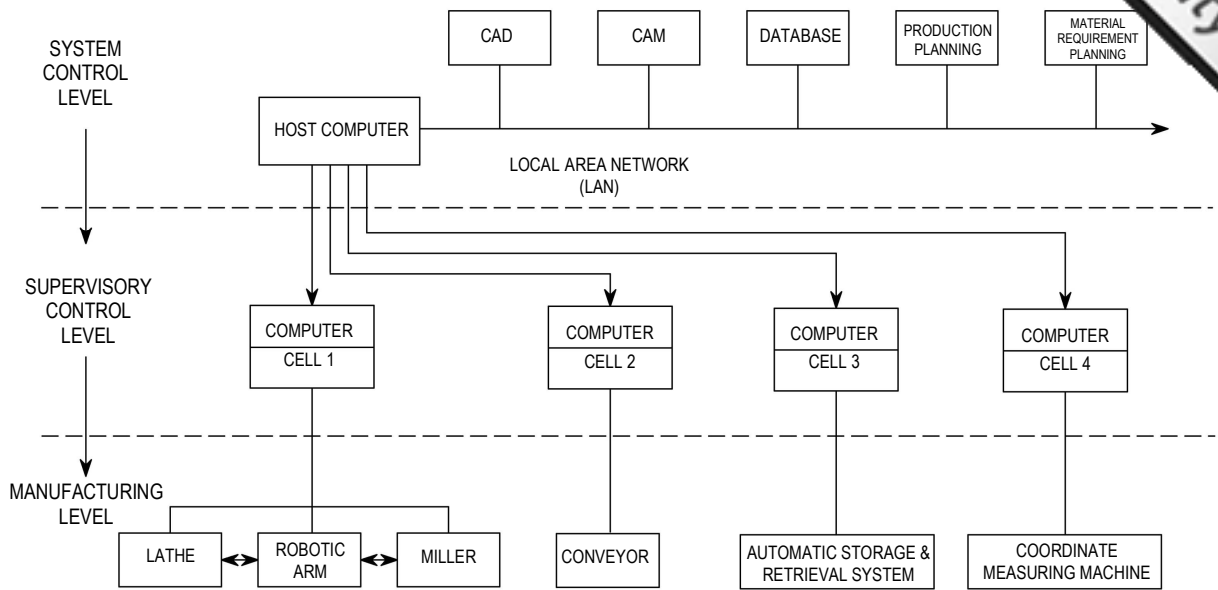

Figure 3

- (a) State briefly three advantages of CIM. (6 marks)
- (b) Referring to Figure 3, explain briefly how information and computer technology can enhance each of the following:
- (i) designing a product;
 - (ii) manufacturing a product;
 - (iii) quality control of a product;
 - (iv) material storage and handling.
- (12 marks)
- (c) 'Just-in-time' (JIT) is a management strategy which is applied in business and industry. In the manufacturing industry, some components are manufactured by suppliers just a few hours after they were ordered. Such components are delivered to the production line just in time for assembly.
- (i) Give four advantages of 'JIT manufacturing'. (4 marks)
 - (ii) Give three impacts of computer technology on 'JIT manufacturing'. (3 marks)

END OF PAPER

HONG KONG EXAMINATIONS AND ASSESSMENT AUTHORITY
HONG KONG DIPLOMA OF SECONDARY EDUCATION EXAMINATION

DESIGN AND APPLIED TECHNOLOGY PAPER 2D
Electronics

SAMPLE PAPER

Time Allowed: 1 hour
This paper must be answered in English

Candidates are required to attempt any **TWO** questions.

Write all answers in the answer book.

Not to be taken away before the
end of the examination session

1. (a) Figure 1(a) shows a circuit diagram.

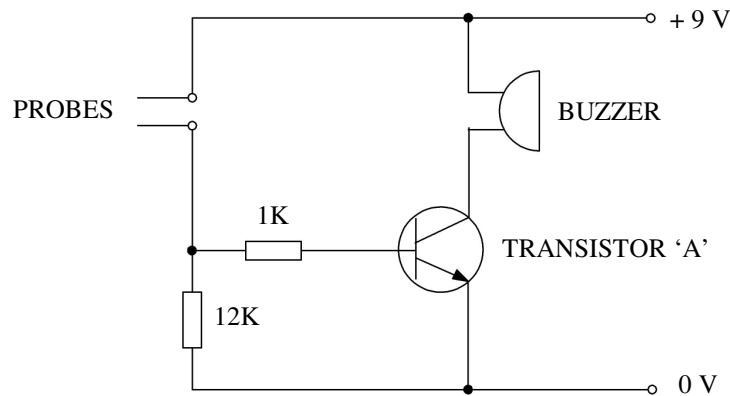

Figure 1(a)

- (i) Explain the function of transistor 'A' in this circuit.
- (ii) Explain the operation of the circuit.
- (iii) Suggest one practical application of the circuit. (6 marks)

- (b) (i) Copy and complete Figure 1(b) into the answer book to show another circuit of similar function using a 741 Operational Amplifier and with an output that would help hearing impaired users. (5 marks)
- (ii) Explain the operation of the circuit that you have suggested in (b) (i). (4 marks)

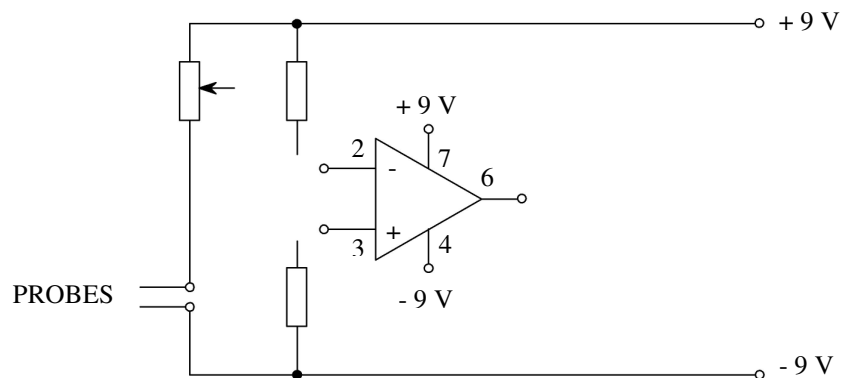

Figure 1(b)

- (c) (i) Give two advances in technology that have contributed to the 'miniaturisation' of consumer electronic products such as mobile phones and digital cameras. (4 marks)
- (ii) State one positive impact and one negative impact of 'miniaturisation' in consumer electronic products in daily life. Give one reason to support each of your answers. (6 marks)

2. Figure 2(a) shows the symbols of four logic gates.

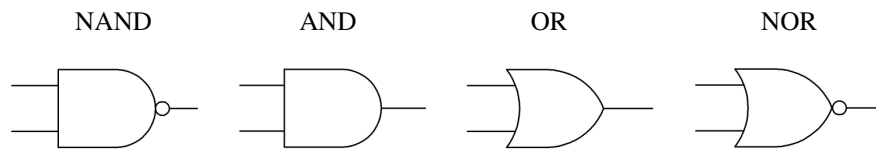

Figure 2(a)

- (a) Using annotated sketches, show how to build the AND, OR and NOR logic gates by combining a number of the NAND gates. (6 marks)
- (b) State two advantages of using only NAND gates to construct logic circuits. (4 marks)
- (c) Construct a time-delay circuit using two NAND gates together with a fixed resistor and a capacitor. Copy and complete Figure 2(b) below in the answer book to illustrate your answer. (4 marks)

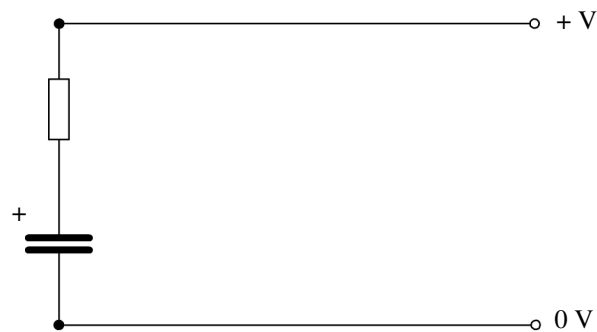

Figure 2(b)

- (d) (i) Construct a logic circuit of the set-reset flip-flop as shown in Figure 2(c) using two NAND gates. (4 marks)
- (ii) Draw the truth table of the logic circuit showing the logic states of S, R, Q and \bar{Q} . (2 marks)
- (iii) Explain briefly how a flip-flop works and suggest one application for it. (5 marks)

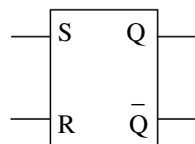

Figure 2(c)

3. Figure 3(a) shows a simple coin-operated compact diskette (CD) dispenser and Figure 3(b) its system diagram.

When a \$5 coin is deposited in the coin slot, the display light turns on, the drawer then opens to deliver one package of CD at a time. The dispenser accepts only \$5 coins and provides no change or return.

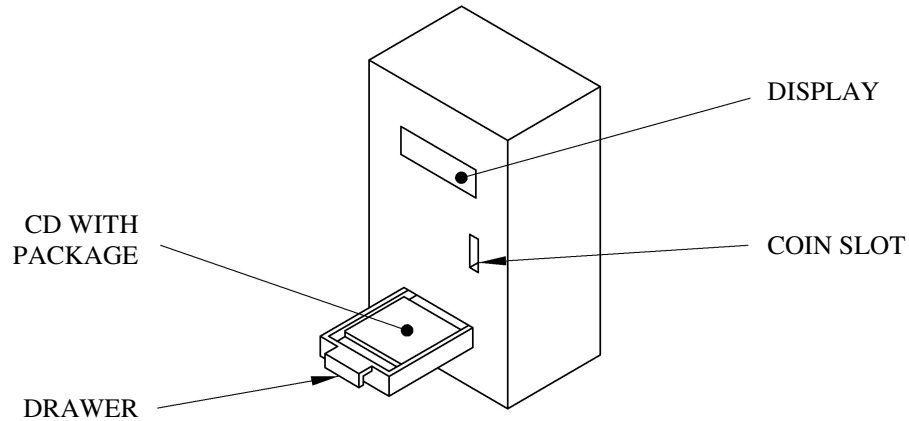

Figure 3(a)

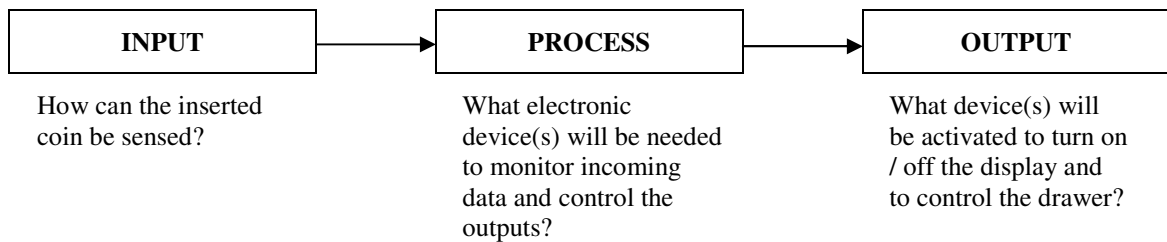

Figure 3(b)

(a) If a micro-controller is used as a major process device for the CD dispenser:

- (i) Suggest two input sensors and two output devices for the system. (4 marks)
- (ii) Show the control system that you have suggested in (a) (i) by copying the 'circuit board' shown in Figure 3(c) in the answer book and adding selected electronic / electrical modules given in Figure 3(d) with their appropriate names.

(Each module can be used once, more than once, or not at all. You may add extra module(s) whenever necessary.) (9 marks)

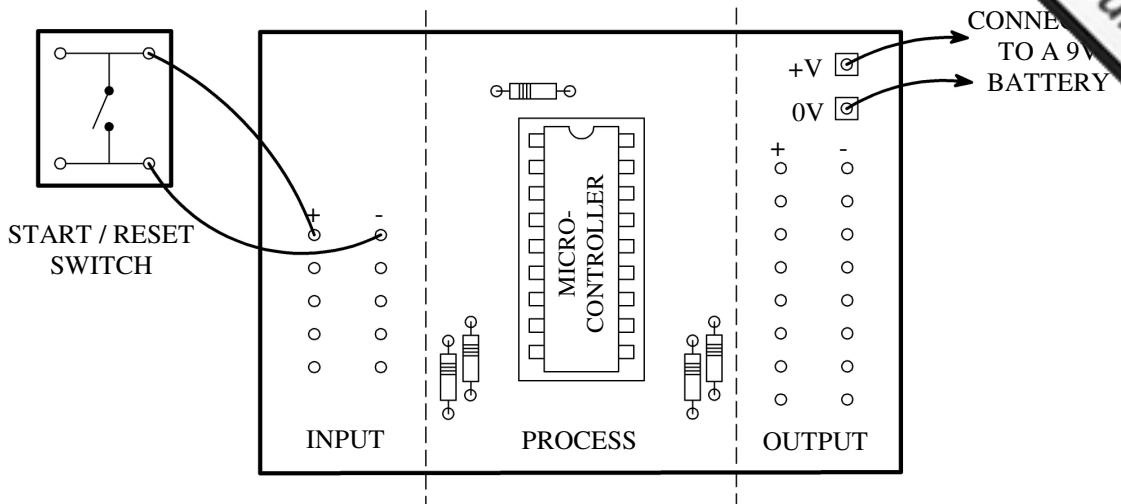

Figure 3(c)

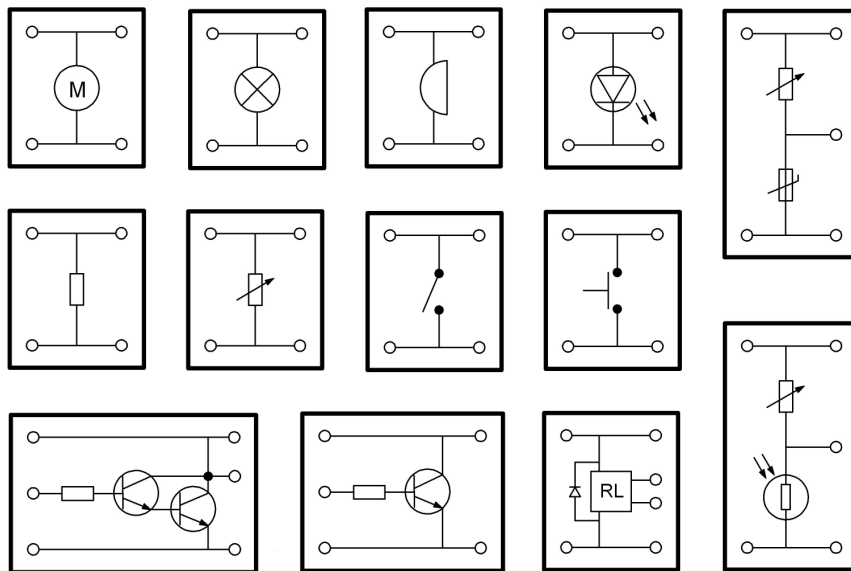

Figure 3(d)

- (b) Suggest three improvements on the function of the CD dispenser, taking into account the restricted number of input and output connections provided by the given micro-controller. (6 marks)
- (c) Describe briefly the function of each of the following components of a micro-controller:
- (i) program memory;
 - (ii) register;
 - (iii) random access memory (RAM).
- (6 marks)

END OF PAPER

DESIGN AND APPLIED TECHNOLOGY PAPER 2E
Visualisation and CAD Modelling

Question-Answer Book
SAMPLE PAPER

Time allowed: 1 hour
This paper must be answered in English

INSTRUCTIONS

- (1) Write your candidate number in the appropriate space provided on Page 1.
- (2) Stick the barcode label in the spaces provided on Pages 1, 5 and 9.
- (3) Candidates are required to answer any **TWO** questions only.
- (4) Attempt all answers in this Question-Answer Book.
- (5) Unless otherwise stated:
 - (a) all dimensions given are in millimetres;
 - (b) all solutions must be full size;
 - (c) all construction lines must be left in each solution.
- (6) Use your own judgement for any dimensions not given.

Please stick the barcode label in the spaces provided on Pages 1, 5 and 9.

| | | | | | | | | | | |
|------------------|--|--|--|--|--|--|--|--|--|--|
| Candidate Number | | | | | | | | | | |
|------------------|--|--|--|--|--|--|--|--|--|--|

| Marker's Use Only | Examiner's Use Only |
|-------------------|---------------------|
| Marker No. | Examiner No. |
| | |

| Question No. | MARKS | |
|--------------|-------|--|
| 1 | | |
| 2 | | |
| 3 | | |
| Total | | |

| Checker's Use Only | |
|--------------------|--|
| Checker No. | |
| Total | |

1. (a) Figure 1(a) shows the logo of an organisation. In the space given below, using 'P' as a centre of enlargement, enlarge the logo to a similar figure with sides in a ratio of 2:1.

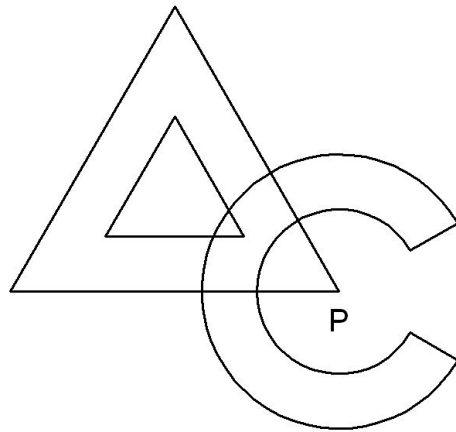

Figure 1(a)

1. (b) (i) Compare 'raster graphics' with 'vector graphics' in relation to digital imaging. Support your answer with annotated sketches. (6 marks)
- (ii) On Figure 1(b), indicate and explain how raster graphics and vector graphics are used in logo design. (4 marks)

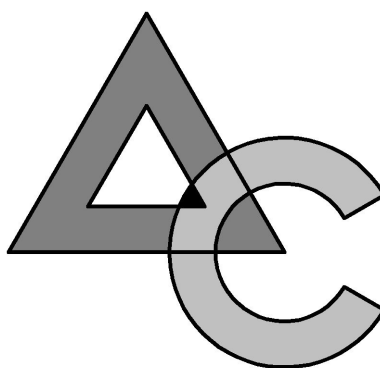

Figure 1(b)

1. (c) Discuss the impact of computer technology on each of the following aspects:
- (i) visualisation of graphic design;
 - (ii) prototyping in product design.

Illustrate each answer with one example.

(6 marks)

Please stick the barcode label here.

2. (a) Using annotated sketches, show the results of the following Boolean operations on the two primitive solids shown in Figure 2(a):
- (i) union;
 - (ii) subtract;
 - (iii) intersect.

(3 marks)

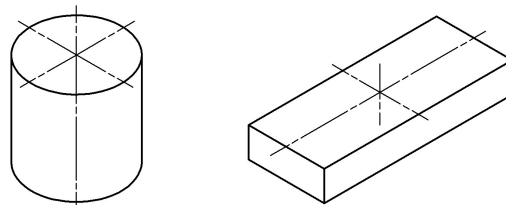

Figure 2(a)

2. (b) Figure 2(b) shows the 3D CAD model of an object.

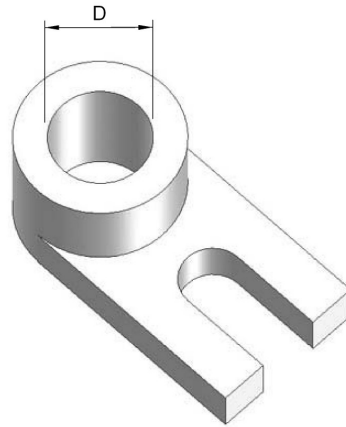

Figure 2(b)

- (i) Using annotated sketches, show the major steps in constructing the 3D CAD model. (10 marks)

2. (b) (ii) State two advantages of 'parametric modelling'.

(iii) Using annotated sketches, show how to use the parametric feature of a 3D CAD software to change the diameter of the hole from D to $0.5D$. (4 marks)

Please stick the barcode label here.

2. (c) State four advantages of 'CAD modelling' in an industrial design process. (4 marks)

3. Figure 3(a) shows two views of a wooden bookshelf.

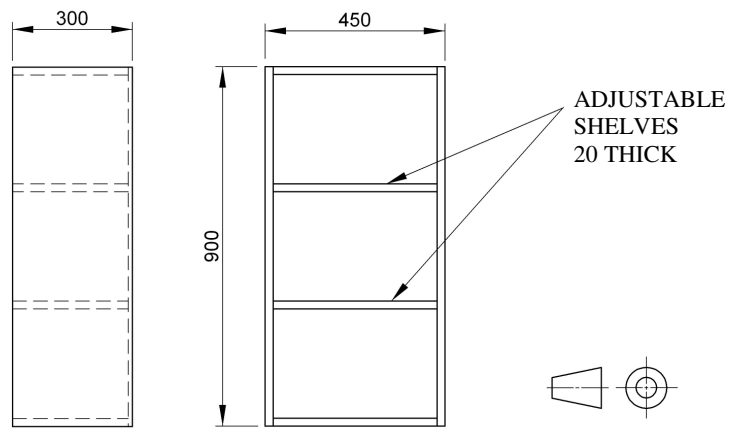

Figure 3(a)

- (a) In the space provided below:
- (i) Produce a two-point perspective sketch of the bookshelf. Add colour, shading and texture to your drawing. (10 marks)
 - (ii) Using an enlarged diagram, illustrate a method of holding the adjustable shelves in position. (5 marks)

3. (b) You are required to produce an animation using 3D CAD software for assembling the assembly from its component parts as shown in Figure 3(b).

Using annotated sketches, show the main stages of animating the assembly. (10 marks)

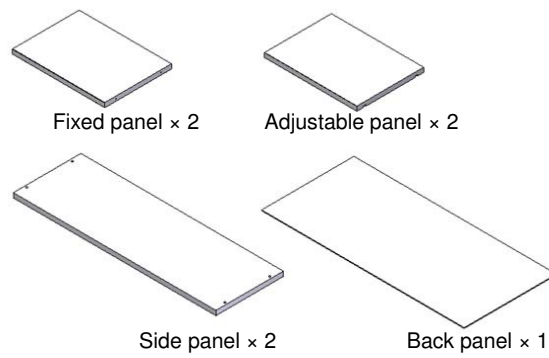

Figure 3(b)

End of Paper