

## BIOLOGY PAPER 1 (Sample Paper)

Time allowed: 2 hours 30 minutes  
This paper must be answered in English.

### GENERAL INSTRUCTIONS

1. There are **TWO** sections, A and B, in this Paper. Section A carries 36 marks and Section B carries 84 marks. You are advised to finish Section A in about 35 minutes.
  2. Section A consists of multiple-choice questions in this question book. Section B contains conventional questions printed separately in Question-Answer Book B.
  3. Answers to Section A should be marked on the Multiple-choice Answer Sheet while answers to Section B should be written in the spaces provided in Question-Answer Book B. **The Answer Sheet for Section A and the Question-Answer Book for Section B must be handed in separately at the end of the examination.**
- 

### SECTION A (MULTIPLE-CHOICE QUESTIONS)

#### INSTRUCTIONS FOR SECTION A

1. Read the instructions on the Answer Sheet carefully. Stick a barcode label and insert the information required in the spaces provided.
2. When told to open this book, you should check that all the questions are there. Look for the words '**END OF SECTION A**' after the last question.
3. All questions carry equal marks.
4. **ANSWER ALL QUESTIONS.** You are advised to use an HB pencil to mark all the answers on the Answer Sheet, so that wrong marks can be completely erased with a clean rubber.
5. You should mark only **ONE** answer for each question. If you mark more than one answer, you will receive **NO MARKS** for that question.
6. No marks will be deducted for wrong answers.

Not to be taken away before the  
end of the examination session

There are 36 questions in this section.

The diagrams in this section are NOT necessarily drawn to scale.

**Directions:** Questions 1 and 2 refer to the electron micrographs and the table below. The electron micrographs show two sub-cellular structures, P and Q, of a eukaryotic cell, while the table shows the relative abundance of these two structures in four cell types in the human body:

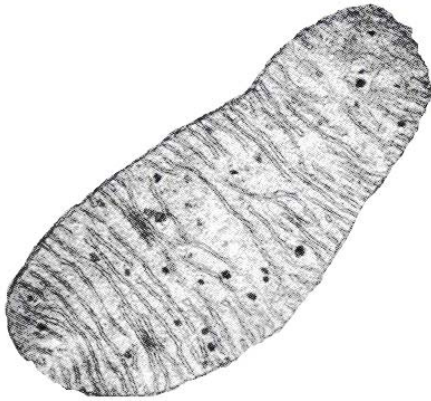

P

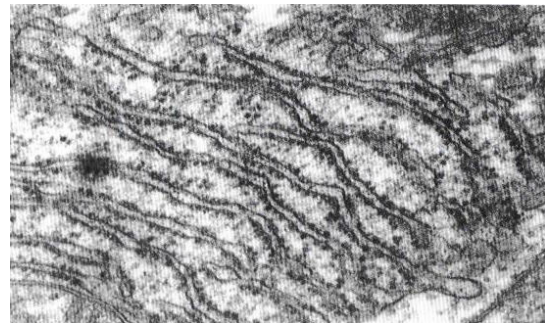

Q

Cell type	Structure P	Structure Q
1	++++	+++
2	++++	+
3	+	+
4	-	-

Key: number of '+' represents the relative abundance of the structure  
 '-' represents absence of the structure

- The relative abundance of structures P and Q in the epithelial cells of the air sacs of the lungs is most likely to be similar to that of
  - cell type 1.
  - cell type 2.
  - cell type 3.
  - cell type 4.
- Which of the following can be found in structure P?
  - ATP
  - enzymes
  - glycogen
  - (1) only
  - (1) and (2) only
  - (2) and (3) only
  - (1), (2) and (3)

3. The diagram below shows the fluid mosaic model of the cell membrane:

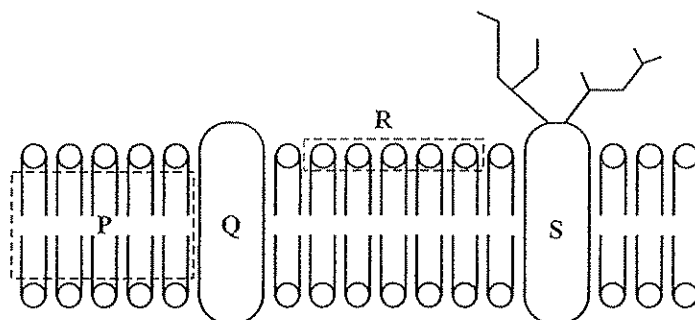

Which labelled part would restrict the movement of ions across the membrane?

- A. P
- B. Q
- C. R
- D. S

4. The diagram below shows the lengths of three fresh potato cylinders before and after they were immersed in three sucrose solutions of different concentrations for one hour:

	Solution X	Solution Y	Solution Z
Before immersion	[ ]	[ ]	[ ]
After immersion	[ ]	[ ]	[ ]

When arranged from the lowest to the highest water potential, the sequence of the three solutions would be

- A. X, Z, Y.
- B. Y, X, Z.
- C. Y, Z, X.
- D. Z, Y, X.

5. Which of the following are made up of proteins?

- (1) finger nails
- (2) chromosomes
- (3) amylase

- A. (1) and (2) only
- B. (1) and (3) only
- C. (2) and (3) only
- D. (1), (2) and (3)

6. A certain weed-killer acts by blocking the flow of electrons along the electron transport chains in photophosphorylation. Which of the following processes would still occur in the plant sprayed with the weed-killer?

- A. formation of ATP
- B. photolysis of water
- C. formation of NADPH
- D. photoactivation of chlorophyll

7. The word equation below shows the conversion of pyruvate to lactate by the enzyme lactate dehydrogenase.



Under anaerobic conditions, if lactate dehydrogenase in a mammalian cell is inhibited, which of the following would occur?

- A. The cell pH would decrease.
  - B. Glycolysis would become slower.
  - C. ATP production would increase.
  - D. The rate of reactions in the Krebs cycle would become higher.
8. The graph below shows the exchange of carbon dioxide between a green plant and the atmosphere under different light intensities:

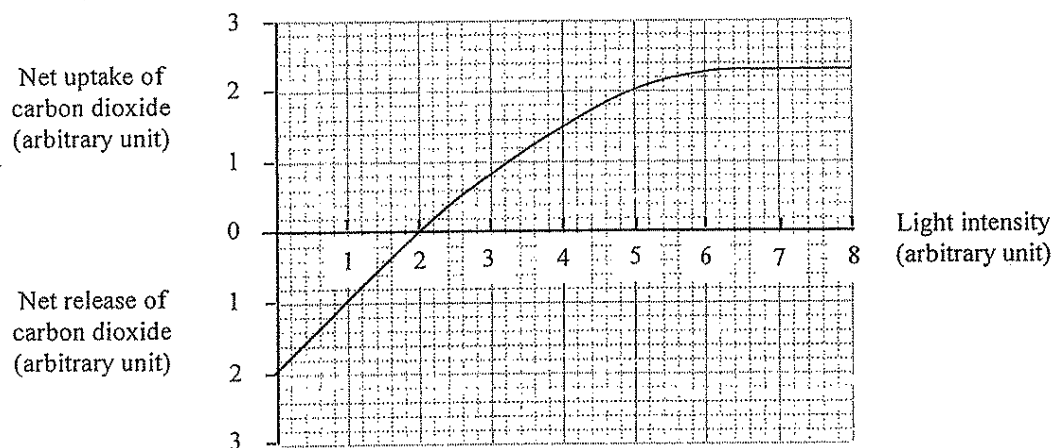

Which of the following can be deduced from the graph?

- (1) At 1 unit of light intensity, only respiration occurs.
  - (2) At 2 units of light intensity, no net photosynthesis occurs.
  - (3) At 7 units of light intensity, the rate of photosynthesis is higher than the rate of respiration.
- A. (1) and (2) only
  - B. (1) and (3) only
  - C. (2) and (3) only
  - D. (1), (2) and (3)
9. For a plant exposed to adequate light, under which of the following conditions would carbon dioxide concentration most likely be the limiting factor on its rate of photosynthesis?

	Temperature ( $^{\circ}\text{C}$ )	Carbon dioxide concentration (%)
A.	5	0.01
B.	5	0.04
C.	25	0.01
D.	25	0.04

**Directions:** Questions 10 and 11 refer to an investigation to study the effect of diet on the performance of athletes. Three groups of athletes were each fed on a different diet for three days. The concentration of glycogen in their leg muscles was then measured. The athletes then exercised on a cycle machine at maximum level until they were exhausted. The results of the investigation are shown in the bar chart below:

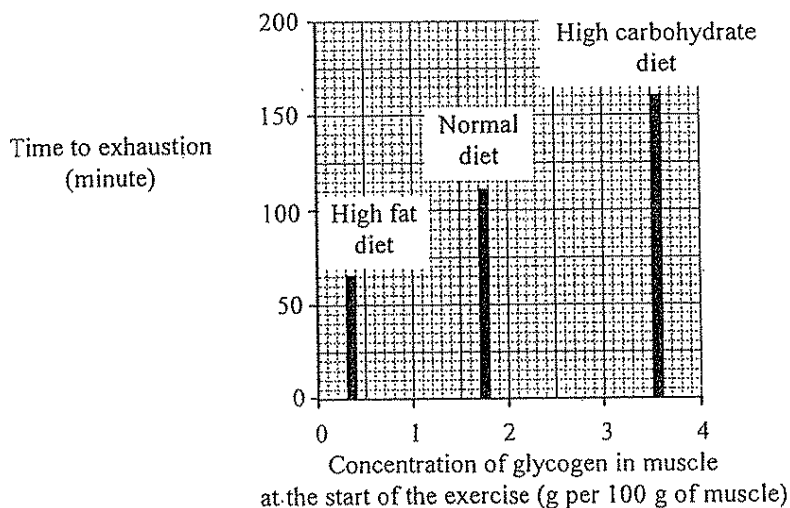

10. In order to make a valid comparison of the investigation results, the amount of proteins, vitamins and minerals in the diets have to be the same. Apart from these substances, what other parameter of the diets has to be identical?
- mass of the food intake
  - water content of the diet
  - energy content of the diet
  - proportion of dietary fibre in the diet
11. With reference to the bar chart, what conclusion can be drawn from the results of the investigation?
- A high-fat diet has a higher energy content than a high-carbohydrate diet.
  - The amount of fat stored in the leg muscles is smaller than the amount of glycogen stored.
  - The leg muscles undergo anaerobic respiration more readily when the athletes have a high-fat diet.
  - The more the glycogen stored, the longer the athlete can carry out vigorous exercise.
12. Which of the following secretions are alkaline and contain digestive enzymes?
- bile and saliva
  - saliva and gastric juice
  - bile and pancreatic juice
  - pancreatic juice and intestinal juice

**Directions:** Questions 13 and 14 refer to the diagram below, which shows a section of the heart:

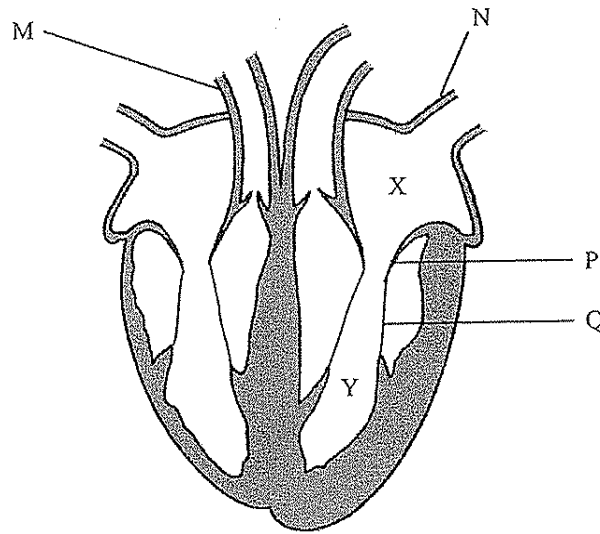

13. Which of the following comparisons of blood vessels M and N is correct?

	<i>Blood vessel M</i>	<i>Blood vessel N</i>
A.	thicker wall	thinner wall
B.	carbon dioxide present	carbon dioxide absent
C.	lower blood pressure	higher blood pressure
D.	lower urea content	higher urea content

14. Which of the following causes the closure of structure P?

- A. increase in tension of structure Q
- B. decrease in tension of structure Q
- C. decrease in pressure of chamber X
- D. increase in pressure of chamber Y

**Directions:** Questions 15 to 17 refers to the photomicrograph below which shows a section of the human

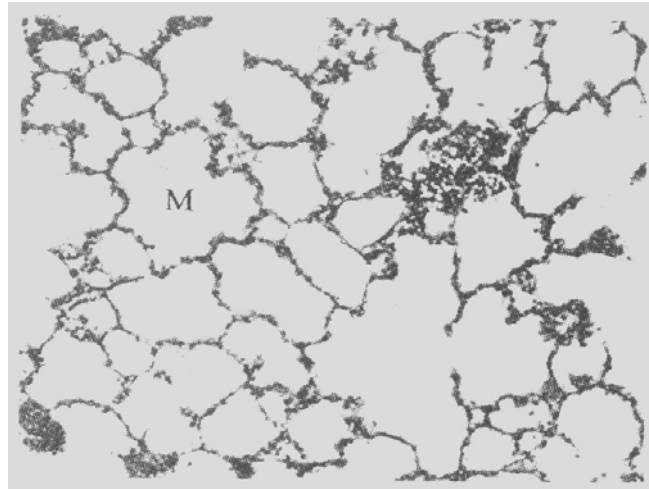

15. Which of the following features allow structures M to adapt to their function?

- (1) folded surface
- (2) thin and ciliated wall
- (3) rich supply of blood capillaries

- A. (1) and (2) only
- B. (1) and (3) only
- C. (2) and (3) only
- D. (1), (2) and (3)

16. The air in structure M consists mostly of

- A. nitrogen.
- B. oxygen.
- C. water vapour.
- D. carbon dioxide.

17. What is the long-term effect of cigarette smoking on structure M?

- A. The size of structure M decreases.
- B. The number of structure M decreases.
- C. The wall of structure M becomes more folded.
- D. The lumen of structure M becomes filled with blood.



18. Of the following groups of people, which group may have the highest risk of liver cancer?

- A. people suffering from alcoholism
- B. people suffering from diabetes
- C. people with smoking habits
- D. people with weight problems

**Directions:** Questions 19 and 20 refer to the diagrams below, which show four different types of cells found in humans:

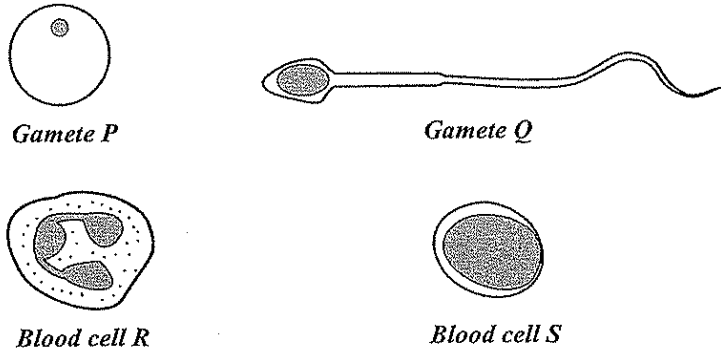

Key:  nucleus

19. Which of the following statements about the chromosome content of the cells is / are correct?

- (1) P and Q contain the same number of chromosomes.
- (2) P and R must contain an X chromosome.
- (3) Q and S must contain a Y chromosome.

- A. (1) only
- B. (3) only
- C. (1) and (2) only
- D. (2) and (3) only

20. Which of the following comparisons between the functions of blood cells R and S is correct?

- | <b>Blood cell R</b>    | <b>Blood cell S</b> |
|------------------------|---------------------|
| A. produces antitoxins | for blood clotting  |
| B. engulfs bacteria    | for blood clotting  |
| C. produces antitoxins | produces antibodies |
| D. engulfs bacteria    | produces antibodies |



**Directions:** Questions 21 and 22 refer to the diagram below which shows the distribution of a type of light-sensitive cells on the surface of the retina:

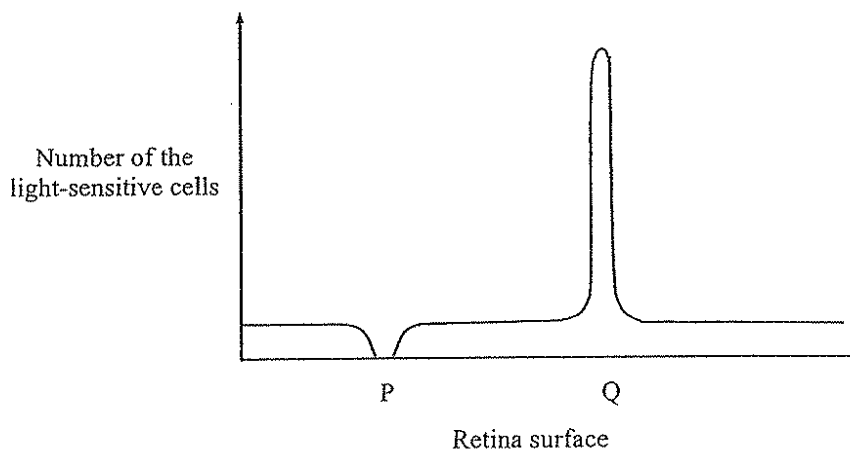

21. Which of the following correctly identifies the type of light-sensitive cells and region Q?

	<i>Type of light-sensitive cells</i>	<i>Region Q</i>
A.	rods	blind spot
B.	rods	yellow spot
C.	cones	blind spot
D.	cones	yellow spot

22. Which of the following will occur when light is focussed on region P?

- A. no image will be formed
- B. no vision will be generated
- C. only black and white vision will be generated
- D. colour vision will be generated

23. What is the role of the cerebrum and cerebellum when a person is swimming?

	<i>Cerebrum</i>	<i>Cerebellum</i>
A.	controls muscle contraction	coordinates muscular actions
B.	controls muscle contraction	regulates heart beat
C.	coordinates muscular actions	controls muscle contraction
D.	regulates heart beat	coordinates muscular actions

24. Which of the following is an example of primary succession?

- A. succession occurring on an abandoned farmland
- B. succession after a volcanic eruption
- C. succession after deforestation
- D. succession after a flood

**Directions:** Questions 25 to 27 refer to the diagram below, which shows the flow of energy in an ecosystem. X and Y represent different trophic levels and Z represents another group of organisms in the ecosystem.

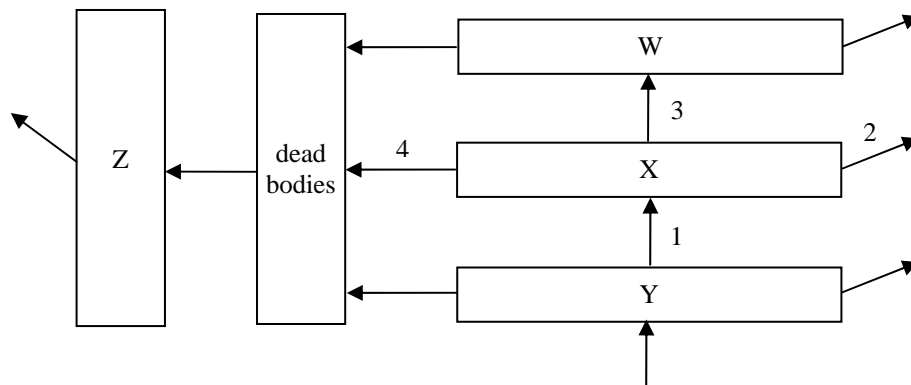

Key:  $\longrightarrow$  direction of energy flow

25. Organisms Z are
- predators.
  - pathogens.
  - parasites.
  - decomposers.
26. Energy is lost from the ecosystem through process 2. What is this process?
- excretion
  - respiration
  - transpiration
  - decomposition
27. With reference to trophic level X, the largest amount of energy flow occurs in
- 1.
  - 2.
  - 3.
  - 4.
28. The gene for colour vision is sex-linked. It can be found in
- cone cells.
  - egg cells.
  - liver cells.
- (1) only
  - (1) and (2) only
  - (2) and (3) only
  - (1), (2) and (3)

29. One of the mRNA codons for the amino acid proline is CCG. How many proline molecules are present in a short peptide which consists of five amino acids and is synthesized from the following DNA template

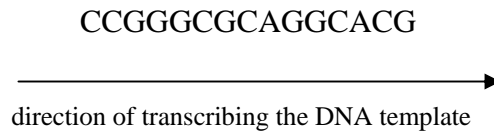

- A. 0  
B. 1  
C. 2  
D. 3
30. The chance of giving birth to a boy to that of a girl is 1:1. This is because
- (1) each egg is fertilized by one sperm only.  
(2) the fertilization of eggs and sperms is random.  
(3) sperms carrying different sex chromosomes are produced in equal proportions.
- A. (2) only  
B. (1) and (3) only  
C. (2) and (3) only  
D. (1), (2) and (3)
31. The photograph below shows the fruit of a plant:

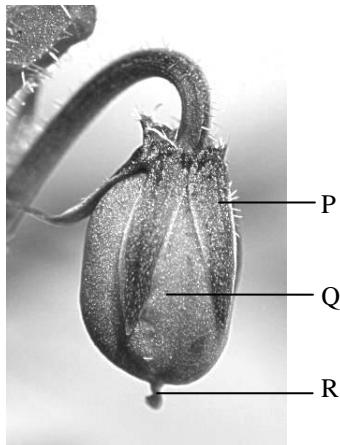

Which of the following statements about the fruit is correct?

- (1) Structure P is formed from the petal.  
(2) Structure Q is developed from the fertilized ovule.  
(3) Structure R is the remains of the style.
- A. (1) only  
B. (3) only  
C. (1) and (2) only  
D. (2) and (3) only

32. The graph below shows the average growth curve of the first 20 years of a girl's life:

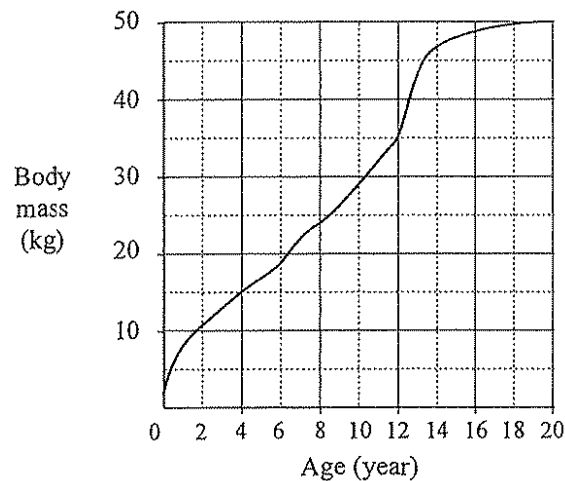

- Based on the curve, girls grow fastest between the ages of
- A. 0 – 2.
  - B. 6 – 8.
  - C. 12 – 14.
  - D. 18 – 20.
33. When the skin is infected by bacteria, the infected area will become swollen because
- A. a lot of bacteria are killed.
  - B. the blood capillaries dilate.
  - C. there is an accumulation of tissue fluid.
  - D. the concentration of antibodies increases.
34. Which of the following diseases **cannot** be prevented by good personal hygiene?
- A. cholera
  - B. haemophilia
  - C. tuberculosis
  - D. athlete's foot
35. Antibodies
- A. act on specific antigens.
  - B. are produced by T lymphocytes.
  - C. are made up of proteins and fats.
  - D. can develop a memory for pathogens.

36. A person was infected by a virus. Forty days later, he was infected again by the same virus. Blood samples were taken from the person at regular intervals and the concentration of the virus was determined. The results are shown in the graph below:

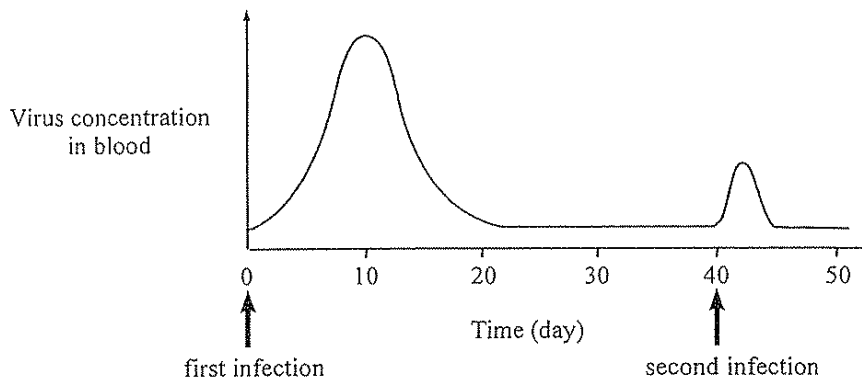

Which of the following graphs best represents the changes in concentration of antibody in the blood?

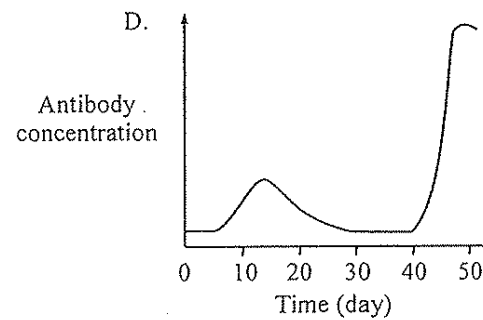
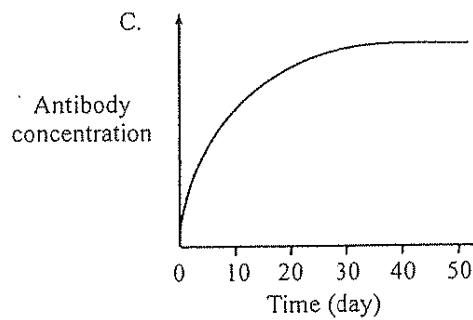
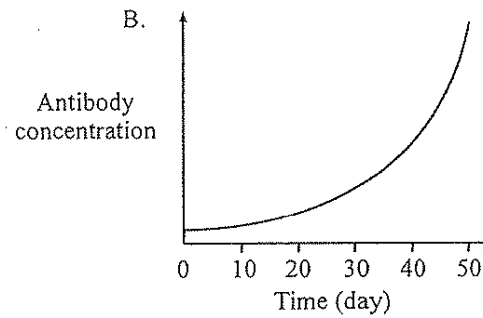
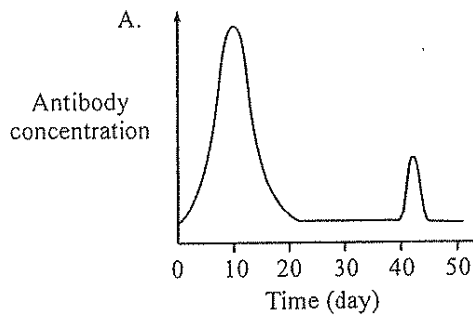

END OF SECTION A

Go on to Question-Answer Book B for questions on Section B

# B

HONG KONG EXAMINATIONS AND ASSESSMENT AUTHORITY  
HONG KONG DIPLOMA OF SECONDARY EDUCATION EXAMINATION

## BIOLOGY PAPER 1 (Sample Paper)

### SECTION B : Question-Answer Book B

This paper must be answered in English.

#### INSTRUCTIONS

- (1) Write your Candidate Number in the space provided on Page 1.
- (2) Stick barcode labels in the spaces provided on Pages 1, 3, 5, 7 and 9.
- (3) Refer to the general instructions on the cover of the Question Book for Section A.
- (4) The questions in this Question-Answer Book carry 84 marks. Answer **ALL** questions.
- (5) Write your answers to Section B in the spaces provided in this Question-Answer Book. Do not write in the margins. Answers written in the margins will not be marked.
- (6) Supplementary answer sheets will be provided on request. Write your candidate number, fill in the question number and stick a barcode label on each sheet. Tie them loosely but securely with a string **INSIDE** this Question-Answer Book.
- (7) Present your answers in paragraphs wherever appropriate.
- (8) The diagrams in this section are **NOT** necessarily drawn to scale.

©香港考試及評核局 保留版權  
Hong Kong Examinations and Assessment Authority  
All Rights Reserved 2008

Please stick the barcode label here.

Candidate Number

Question No.	Marker's Use Only	Examiner's Use Only
	Marker No.	Examiner No.
1		
2		
3		
4		
5		
6		
7		
8		
9		
10		
11		
12		
Total		

**SECTION B**

Answer **ALL** questions. Put your answers in the spaces provided.

1. For each of the biological processes listed in column 1, select **one** type of membrane transport mechanisms listed in column 2 that accounts for the process. Put the appropriate letter in the space provided. (2 marks)

**Column 1**

Haemolysis of red blood cells when placed in 0.1% sodium chloride solution .....

Uptake of oxygen into red blood cells .....

**Column 2**

- A. active transport
- B. diffusion
- C. osmosis
- D. phagocytosis

2. A piece of agricultural land can be used for growing crops, or for growing grass to raise cattle for meat. Explain why crop-growing can provide more food for human consumption than cattle-raising. (4 marks)

.....

.....

.....

.....

.....

.....

.....

.....

.....

Answers written in the margins will not be marked.

Answers written in the margins will not be marked.

Answers written in the margins will not be marked.



Please stick the background paper here.

3. The photograph below shows a kind of dolphin that can be found in the coastal areas of Hong Kong:



(a) Based on *two* features of the dolphin observed in the photograph, state how each feature enables it to adapt to this habitat. (2 marks)

.....

.....

.....

(b) This dolphin is a protected species in Hong Kong. State how *two* human activities might pose threats to its survival in Hong Kong waters. (2 marks)

.....

.....

.....

(c) According to the modern classification systems, dolphin and goldfish belong to the same group but different sub-groups. State *two* structural differences between these two animals that form the basis for classifying them into different sub-groups. (2 marks)

.....

.....

.....

Answers written in the margins will not be marked.

Answers written in the margins will not be marked.

Answers written in the margins will not be marked.

4. The photomicrographs below show changes in a cell when it undergoes a certain type of cell division:

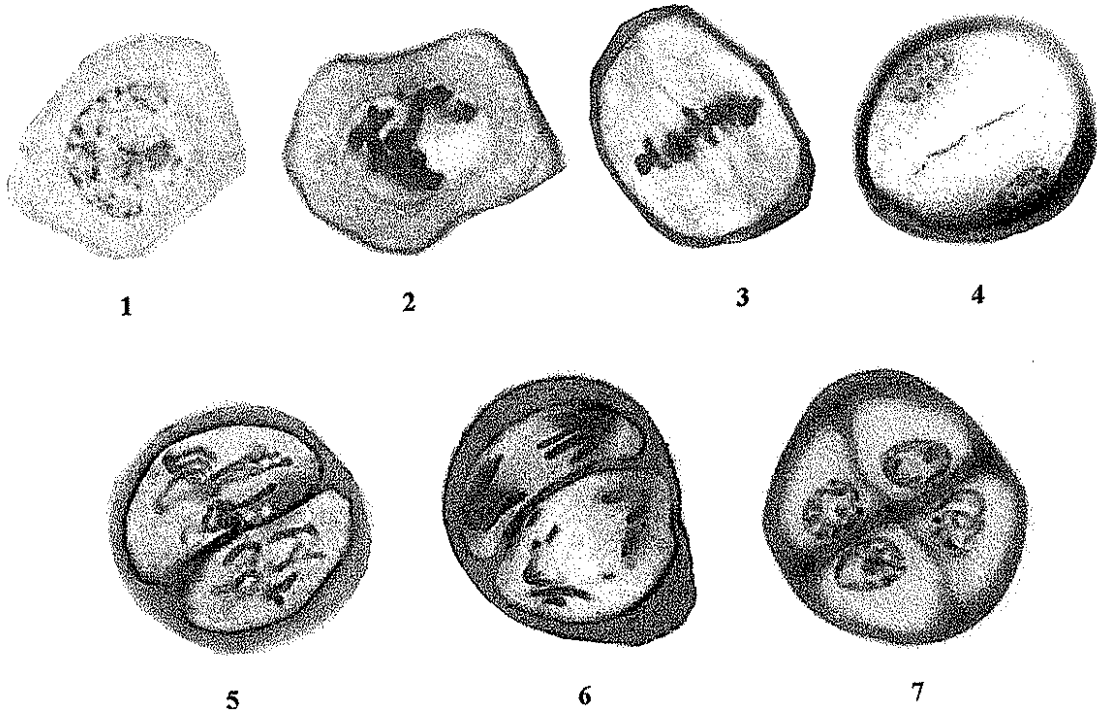

(a) State *two* processes occurring in stage 1 which prepare the cell for this type of cell division. (2 marks)

.....

.....

.....

.....

Answers written in the margins will not be marked.

Answers written in the margins will not be marked.

Answers written in the margins will not be marked.

Please stick the barcode label here.

- (b) Explain the significance of the behaviour of chromosomes in stage 3 to the outcomes of this type of cell division. (4 marks)

---

---

---

---

---

---

---

---

---

---

Answers written in the margins will not be marked.

Answers written in the margins will not be marked.

Answers written in the margins will not be marked.

5. During the course of history, scientists have developed different systems for classifying the diverse range of living organisms based on different criteria. The table below lists some of the different classification systems developed in the past centuries:

Scientist	Linnaeus	Chatton	Copeland	Whittaker	Woese et al.	Woese et al.
Year of proposal	1735	1937	1956	1969	1977	1990
System	2 kingdoms	2 empires	4 kingdoms	5 kingdoms	6 kingdoms	3 domains
Group	(not treated)	Prokaryota	Prokaryota	Prokaryota	Eubacteria	Bacteria
					Archaeobacteria	Archaea
	Vegetabilia	Eukaryota	Protoctista	Protista	Protista	Eukarya
			Plantae	Fungi	Fungi	
Plantae	Plantae			Plantae		
Animalia	Animalia		Animalia	Animalia		

(a) In 1937, Chatton classified all living organisms into two empires. List *two* major differences between these two empires. (2 marks)

.....

.....

.....

.....

(b) Complete the key below, which serves to classify eukaryotic organisms into four kingdoms as proposed by Whittaker: (3 marks)

1a Predominantly unicellular.....Protista  
 1b Multicellular.....2

2a  .....

2b  .....

3a  .....

3b  .....

Answers written in the margins will not be marked.

Answers written in the margins will not be marked.

Answers written in the margins will not be marked.

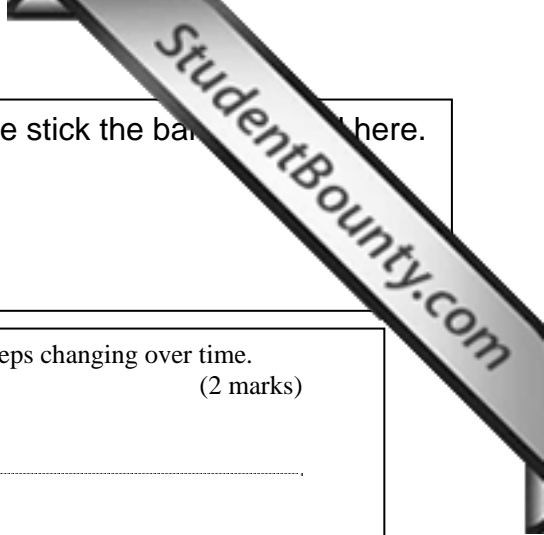

Please stick the barcode here.

(c) Suggest *two* reasons why the classification system of organisms keeps changing over time. (2 marks)

.....

.....

.....

.....

Answers written in the margins will not be marked.

Answers written in the margins will not be marked.

Answers written in the margins will not be marked.

6. The diagram below shows some structures of the leg and a neurone supplying the leg muscle:

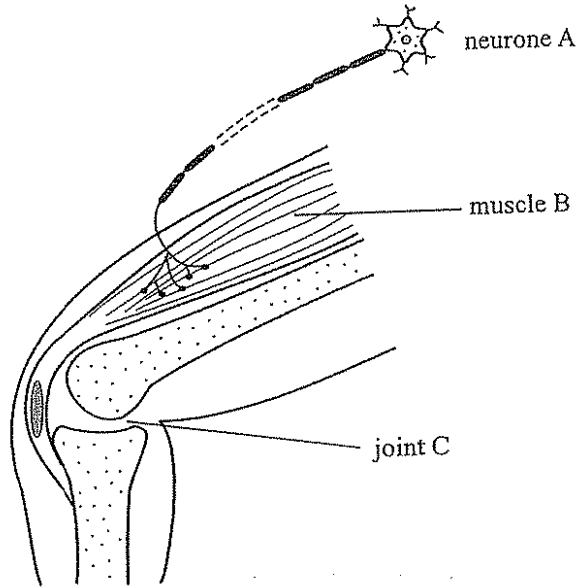

(a) Outline how the arrival of nerve impulses at the nerve endings of neurone A leads to the contraction of muscle B. (3 marks)

.....

.....

.....

.....

.....

.....

(b) Describe the role of joint C in the movement of the leg. (2 marks)

.....

.....

.....

.....

Answers written in the margins will not be marked.

Answers written in the margins will not be marked.

Answers written in the margins will not be marked.

Please stick the barcode label here.

7. Mr and Mrs Chan gave birth to a pair of twins, Anne and Jane. The table below lists some characters shown by the twins:

Character	Anne	Jane
Body mass (at the age of 6)	20 kg	21 kg
Colour vision	normal	normal
Blood group	O	AB
IQ	110	105

(a) State the type of twins they belong to. Explain how you arrive at your answer. (3 marks)

.....

.....

.....

.....

(b) Given that the alleles for the antigens that determine blood groups are  $I^A$ ,  $I^B$  and  $i$ , state the genotypes of Mr and Mrs Chan. (2 marks)

.....

.....

(c) Allele  $I^A$  codes for an enzyme responsible for forming antigen A on the surface of red blood cells. Outline the processes in which allele  $I^A$  is expressed to form this enzyme. (6 marks)

.....

.....

.....

.....

.....

.....

.....

.....

.....

.....

Answers written in the margins will not be marked.

Answers written in the margins will not be marked.

Answers written in the margins will not be marked.



8. The graph below shows the oxygen content of blood in the aorta and that in the vena cava, and the oxygen uptake of a person performing exercise of different intensities. The intensity of exercise is expressed as the energy requirement of the exercise.

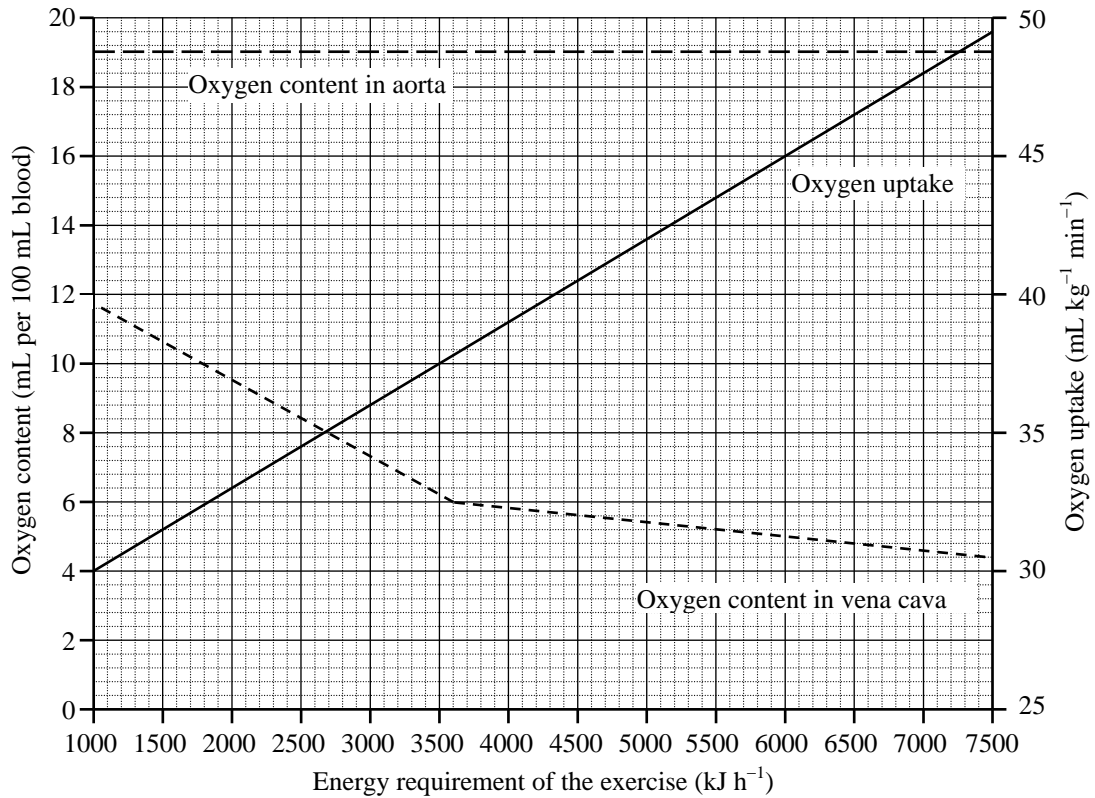

- (a) The energy requirements for running and leisurely cycling are 3600 kJ h<sup>-1</sup> and 1800 kJ h<sup>-1</sup> respectively. Calculate the difference in the blood oxygen content between the aorta and the vena cava for each type of exercise. (2 marks)

Running : \_\_\_\_\_

Cycling : \_\_\_\_\_

Answers written in the margins will not be marked.

Answers written in the margins will not be marked.

Answers written in the margins will not be marked.

Answers written in the margins will not be marked.

(b) How does the difference in blood oxygen content between the two blood vessels change with the intensity of exercise? Account for this change. (4 marks)

---

---

---

---

---

---

---

---

---

---

(c) How does the oxygen uptake of the person change with the intensity of exercise? Suggest a physiological response that leads to this change. (2 marks)

---

---

---

---

Answers written in the margins will not be marked.

Answers written in the margins will not be marked.

9. One of the applications of enzymes in everyday life is found in biological washing powders. To study the effectiveness of a biological washing powder, three identical skirts with identical fat stains were washed with the washing powder solutions of the same concentration but at different water temperatures. The investigation and its results are outlined below:

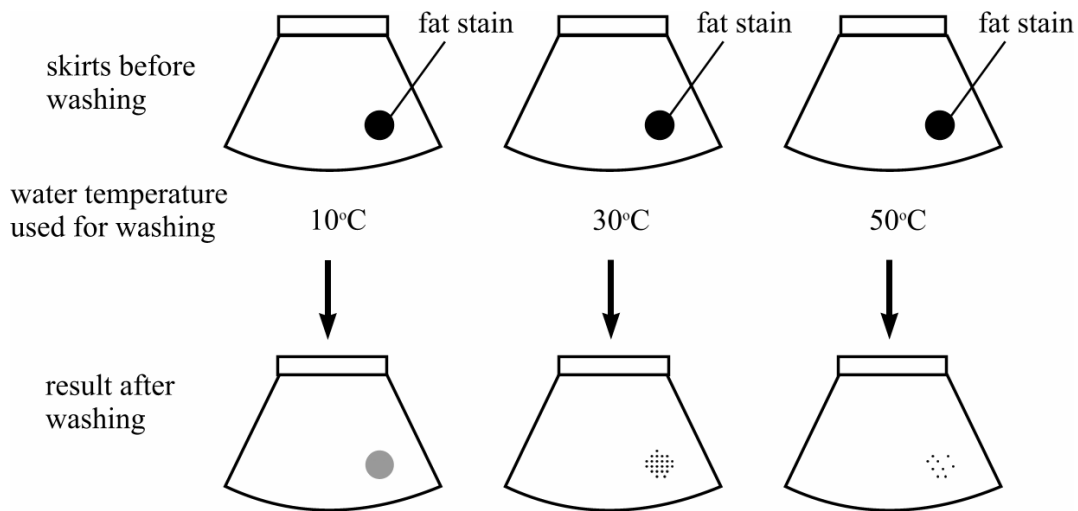

(N.B. The investigation was repeated at the three temperatures, but no washing powder was used. The fat stains on all three skirts remained unchanged.)

(a) Suggest an explanation why the fat stain can be removed by using the biological washing powder. (3 marks)

.....

.....

.....

.....

.....

.....

(b) What conclusion can be drawn from the results of this investigation? (1 mark)

.....

.....

Answers written in the margins will not be marked.

Answers written in the margins will not be marked.

Answers written in the margins will not be marked.



10. Below is an extract from a pamphlet about influenza:

Influenza (abbreviated flu) is a common infection of the respiratory tract. The pathogens that cause flu are divided into types A, B and C. Each type differs slightly with regard to the antigens carried on the surface of the pathogens. In Hong Kong, the common types of flu are types A and B. If infected, most healthy people will recover by themselves within a week. Antibiotics are not recommended for treating flu. For protection against flu, people can have a vaccination before the onset of the flu season. Each year, the World Health Organization (WHO) will review the composition of the flu vaccines and recommend the type of flu vaccines to be used in the coming flu season.

(a) How is flu transmitted? (1 mark)

.....

(b) Give *two* reasons why antibiotics are not recommended for treating flu. (2 marks)

.....

.....

.....

.....

(c) Suggest why the composition of the flu vaccines has to be reviewed each year. (2 marks)

.....

.....

.....

.....

(d) In a class of students, one of them got flu. Some of his neighbouring classmates became infected while some did not. Besides vaccination, suggest *two* other reasons why some of his neighbouring classmates were not infected by flu. (2 marks)

.....

.....

.....

.....

Answers written in the margins will not be marked.

Answers written in the margins will not be marked.

Answers written in the margins will not be marked.

11. (a) The graph below shows changes in the rate of secretion of two pancreatic hormones, A and B, at different blood glucose levels in humans:

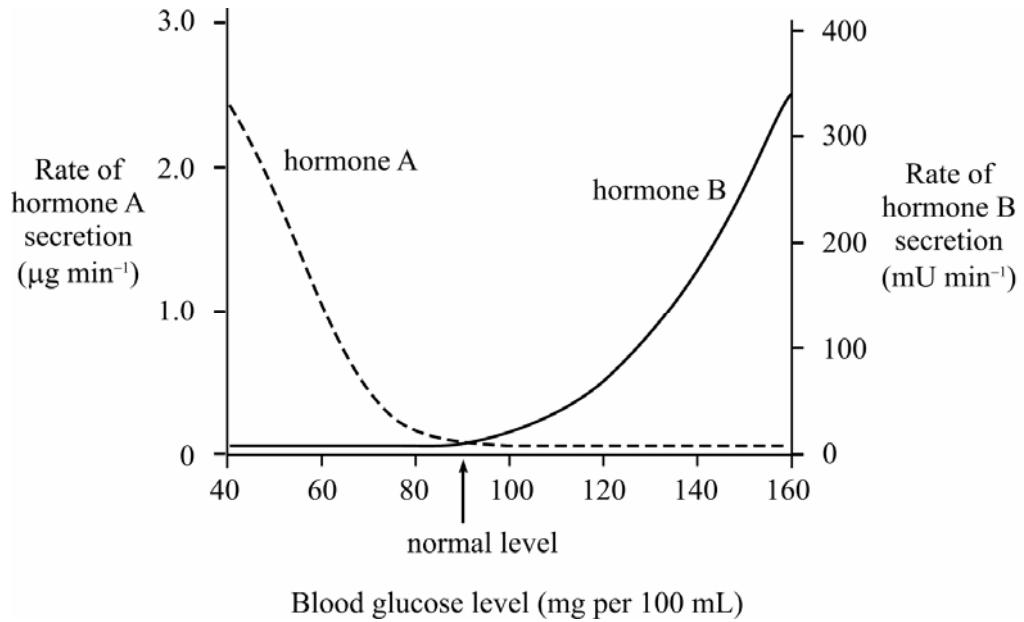

- (i) Which hormone will play an active role in the homeostatic control of blood glucose level when it drops from the normal level to 40 mg per 100 mL? Give evidence from the graph to support your answer. (3 marks)

.....

.....

.....

.....

.....

- (ii) Name hormone A and state how this hormone contributes to the homeostatic control of blood glucose level. (3 marks)

.....

.....

.....

.....

.....

Answers written in the margins will not be marked.

Answers written in the margins will not be marked.

Answers written in the margins will not be marked.

- (b) John suffers from a certain type of diabetes because his body cells fail to respond to one of the pancreatic hormones. If you were a doctor, give *two* pieces of advice to John for controlling the severity of his disease. (2 marks)

---

---

---

---

Answers written in the margins will not be marked.

Answers written in the margins will not be marked.

Answers written in the margins will not be marked.



12. Hydrogen and nitrogen are essential components of proteins. Compare and contrast the processes by which non-leguminous plants acquire these two elements from the environment and describe how they can be incorporated together to form proteins in mesophyll cells. (11 marks)

---

---

---

---

---

---

---

---

---

---

---

---

---

---

---

---

---

---

---

---

---

---

---

---

---

---

---

---

---

---

Answers written in the margins will not be marked.

Answers written in the margins will not be marked.

Answers written in the margins will not be marked.

Answers written in the margins will not be marked.

Answers written in the margins will not be marked.

Lined writing area with 20 horizontal dashed lines for student answers.

**END OF PAPER**

Answers written in the margins will not be marked.