



General Certificate of Secondary Education
2015

Centre Number

--	--	--	--	--

Candidate Number

--	--	--	--	--

Technology and Design

Unit 2:
Systems and Control

Element 1: Electronic and
Microelectronic Control Systems



GTD21

[GTD21]

MONDAY 8 JUNE, AFTERNOON

TIME

1 hour.

INSTRUCTIONS TO CANDIDATES

Write your Centre Number and Candidate Number in the spaces provided at the top of this page.

You must answer the questions in the spaces provided.

Do not write outside the boxed area on each page or on blank pages.

Questions which require drawing or sketching should be completed using an H.B. pencil.

All other questions must be completed using blue or black ink only.

Do not write in pencil or with a gel pen.

Answer **all** questions.

INFORMATION FOR CANDIDATES

The total mark for this paper is 80.

Figures in brackets printed down the right-hand side of pages indicate the marks awarded to each question or part question.



BLANK PAGE
DO NOT WRITE ON THIS PAGE

9397



16GTD2102



Formulae for GCSE Technology and Design

You should use, where appropriate, the formulae given below when answering questions which include calculations.

1 Potential Difference = current \times resistance ($V = I \times R$)

2 For potential divider

$$V_2 = \frac{R_2}{R_1 + R_2} \times V_T$$

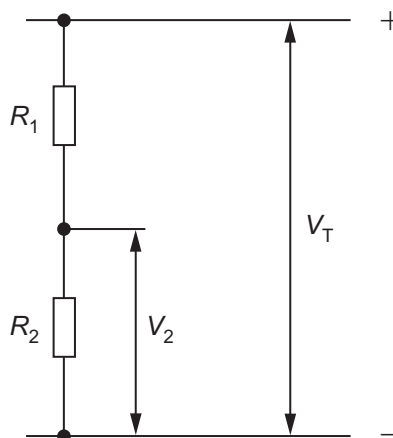

3 Series Resistors $R_T = R_1 + R_2 + R_3 \text{ etc}$

Parallel Resistors $\frac{1}{R_T} = \frac{1}{R_1} + \frac{1}{R_2}$ or $R_T = \frac{R_1 \times R_2}{R_1 + R_2}$

4 Time Constant $T = R \times C$

[Turn over



Answer **all** questions

1 (a) Analogue and digital signals are both used in electronic circuits.

(i) From the list below select **two** digital electronic components and **two** analogue electronic components

- PTM switch
- Thermistor
- LDR
- LED

Digital components _____

Analogue components _____

_____ [4]

(ii) Use the Voltage/Time graph below to show an example of a digital signal and an analogue signal

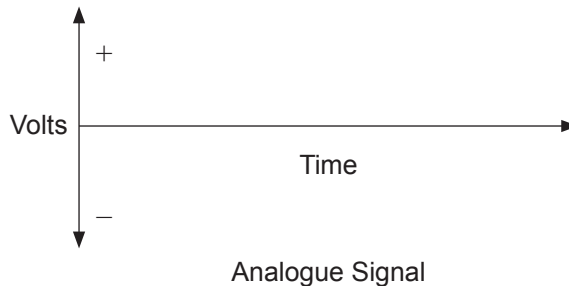
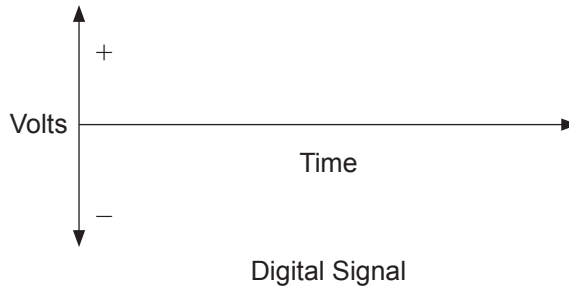

[2]



(b) Fig. 1 shows two circuit outlines (a) and (b) each of which requires the inclusion of a 9 volt battery, a $3.3\text{ k}\Omega$ and a $4.7\text{ k}\Omega$ resistor. The battery should be included at **A** and the resistors between **B** and **C**. In (a) the resistors should be in series and in (b) the resistors should be in parallel.

(i) Complete both circuits.

[3]

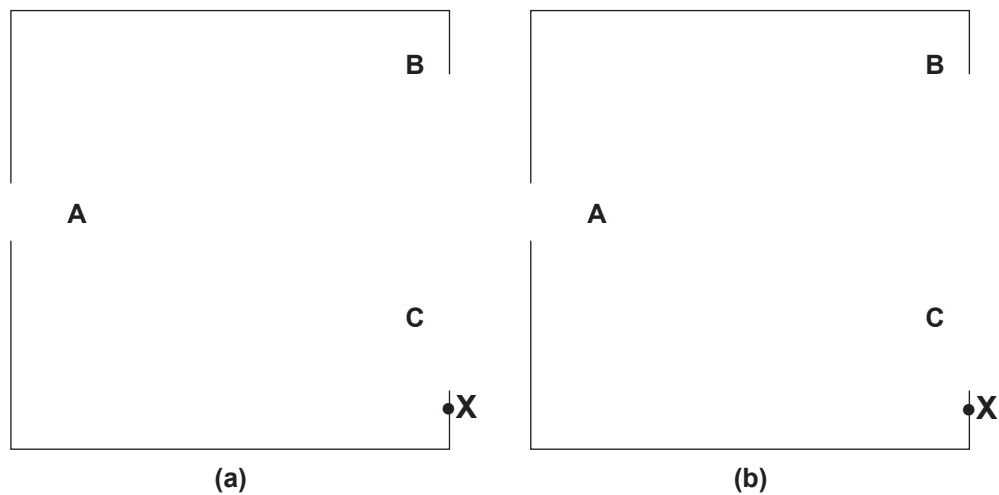

Fig. 1

(ii) Calculate the current at point **X** in each circuit in Fig. 1.

Current Fig. 1(a) _____ [3]

Current Fig. 1(b) _____ [4]

[Turn over



(c) Fig. 2 shows a potential divider circuit.

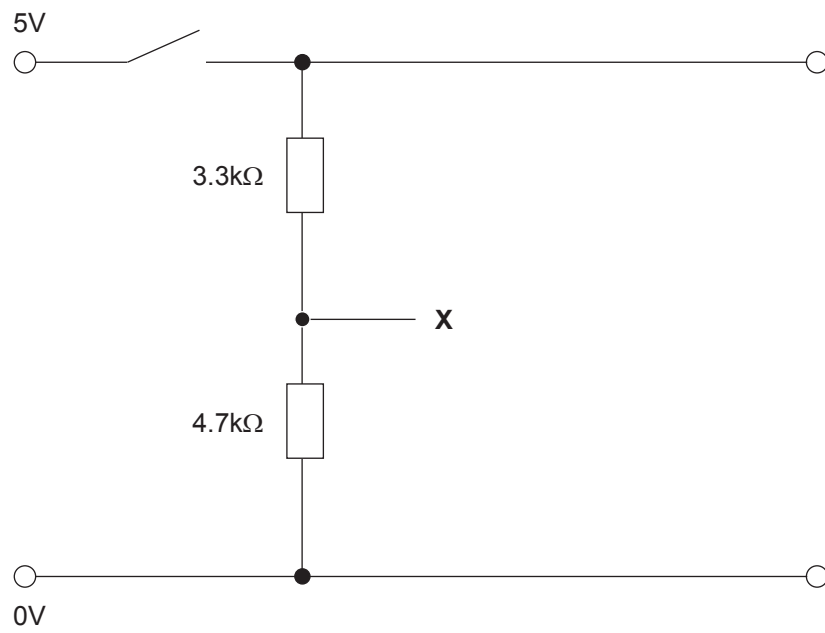

Fig. 2

(i) Calculate the output voltage at point X.

[4]



The circuit in **Fig. 3** has some component symbols missing.

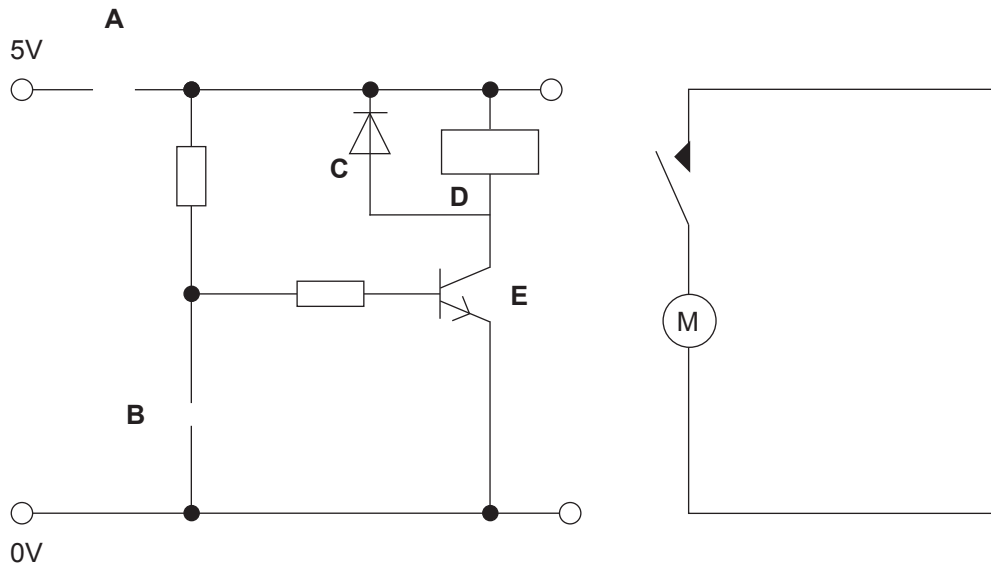

Fig. 3

(ii) Insert a PTM switch symbol at **A** and a capacitor symbol at **B** in **Fig. 3**. [2]

(iii) What do the letters PTM stand for?

_____ [1]

(iv) The value of a capacitor is often expressed in μF and nF . What do μF and nF stand for?

μF _____

nF _____ [2]

[Turn over



(d) (i) Name the electronic component symbols labelled **C**, **D** and **E** in **Fig. 3**.

C _____

D _____

E _____ [3]

(ii) Explain how this circuit operates to produce an output, ensuring that the function of all components is discussed.

_____ [8]

(iii) When testing this circuit it was decided that a second PTM switch could be helpful in the circuit.

Add this switch to the circuit in **Fig. 3** so that it is parallel with the capacitor. [2]



Explain the purpose of adding this second switch.

Explanation _____ [2]

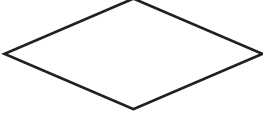

- 2 (a) In the construction of flow charts it is important to use the correct and appropriate symbols. Complete **Table 1** by inserting the correct name or drawing of the symbol.

Table 1

Symbol	Name of Symbol
	
	Expression or Increment
	
	Do Macro
	Macro
	

[6]

[Turn over



(b) (i) Draw the electronic symbol for a microcontroller (PIC).

[2]

(ii) Draw the electronic symbol for an LED.

[1]

(iii) Draw and name the electronic component that is used to protect an LED within a PIC electronic circuit.

Name of electronic component: _____ [2]



(c) A systems program is required for a washing machine that controls a wash and spin routine.

Three flow charts are required to represent the operating routines for the washing machine.

(i) The first flow chart macro is called WATER IN. It should be completed in Fig. 4 as follows:

A water valve is opened for 8 seconds to fill the washing machine and then the valve is closed.

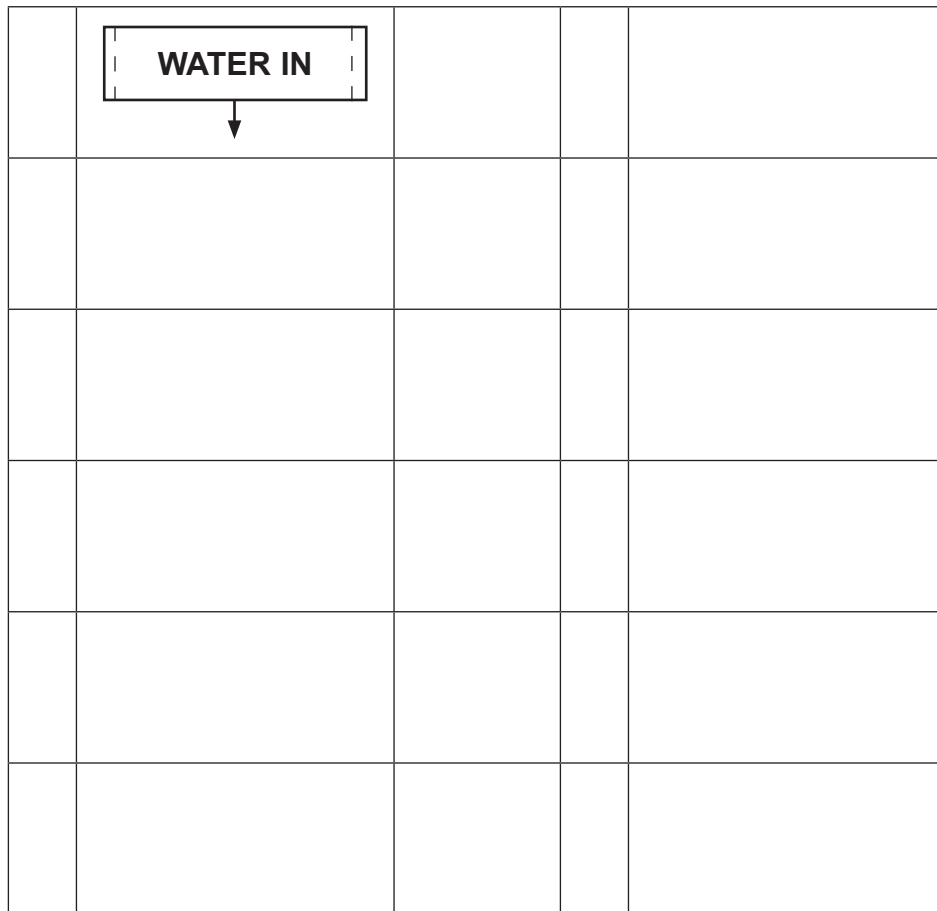

Fig. 4

[4]

[Turn over



- (ii) The second flow chart macro is called HOT. It should be completed in **Fig. 5** as follows:

The temperature of the water entering the washing machine can vary. If the temperature of the water is below 70 °C a heater is turned on until the temperature reaches 70 °C then the heater is turned off and the macro ends.

If however, the temperature of the water entering the machine is 70 °C or above the macro ends.

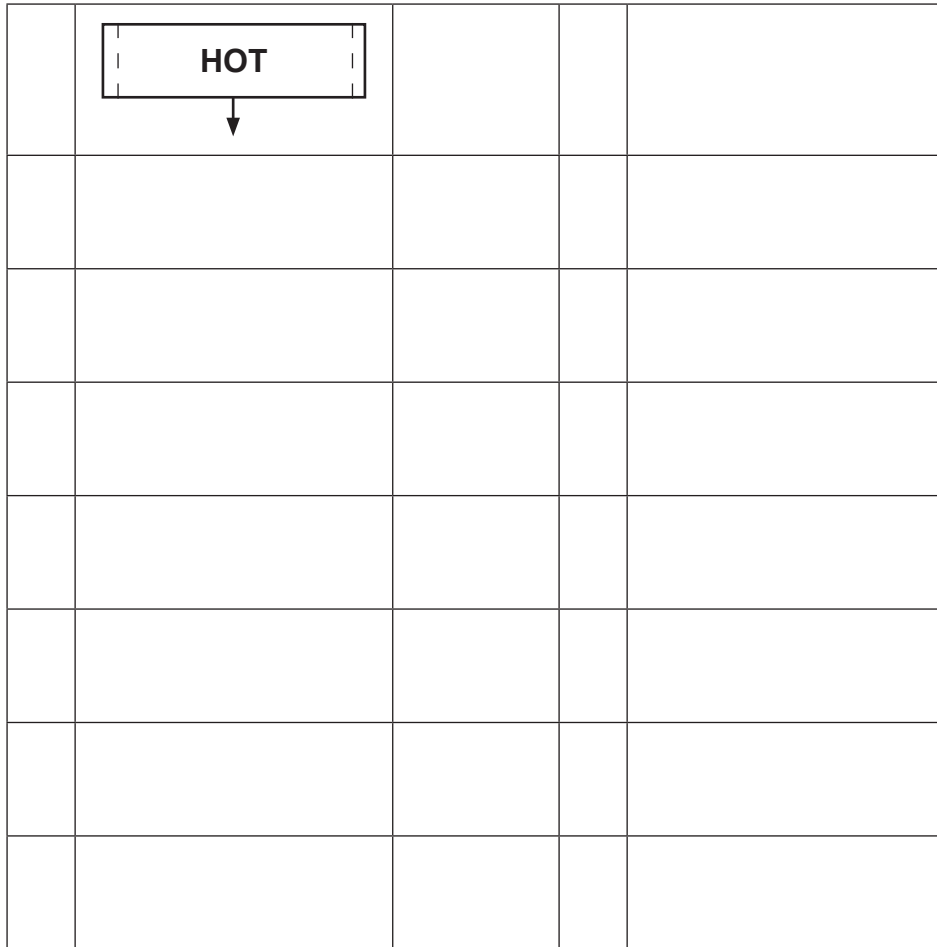

Fig. 5

[7]



(iii) The third flow chart macro is called EMPTY & SPIN. It should be completed in Fig. 6 as follows:

A water pump is turned on for 8 seconds to empty the washing machine at the end of the wash cycle. A fast spin cycle is then switched on to remove moisture from the machine. This spin cycle is operated by an electric motor and switches off after 15 seconds to end the macro.

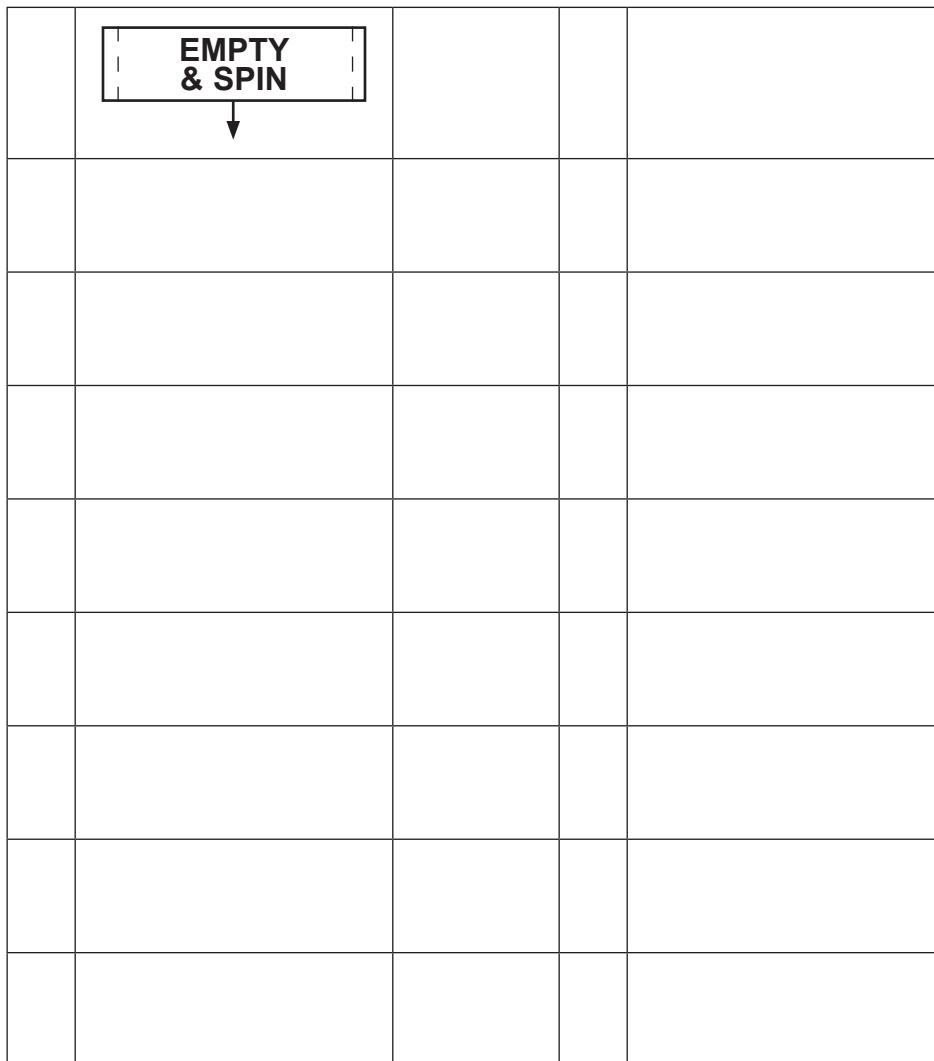

Fig. 6

[7]

[Turn over



(d) Complete the flow chart in **Fig. 7** for the washing machine system as follows:

When a push switch is pressed a red LED comes on and the WATER IN macro operates followed by the HOT macro and the EMPTY & SPIN macro. The macros should operate three times before the red LED is turned off and the washing machine stops.

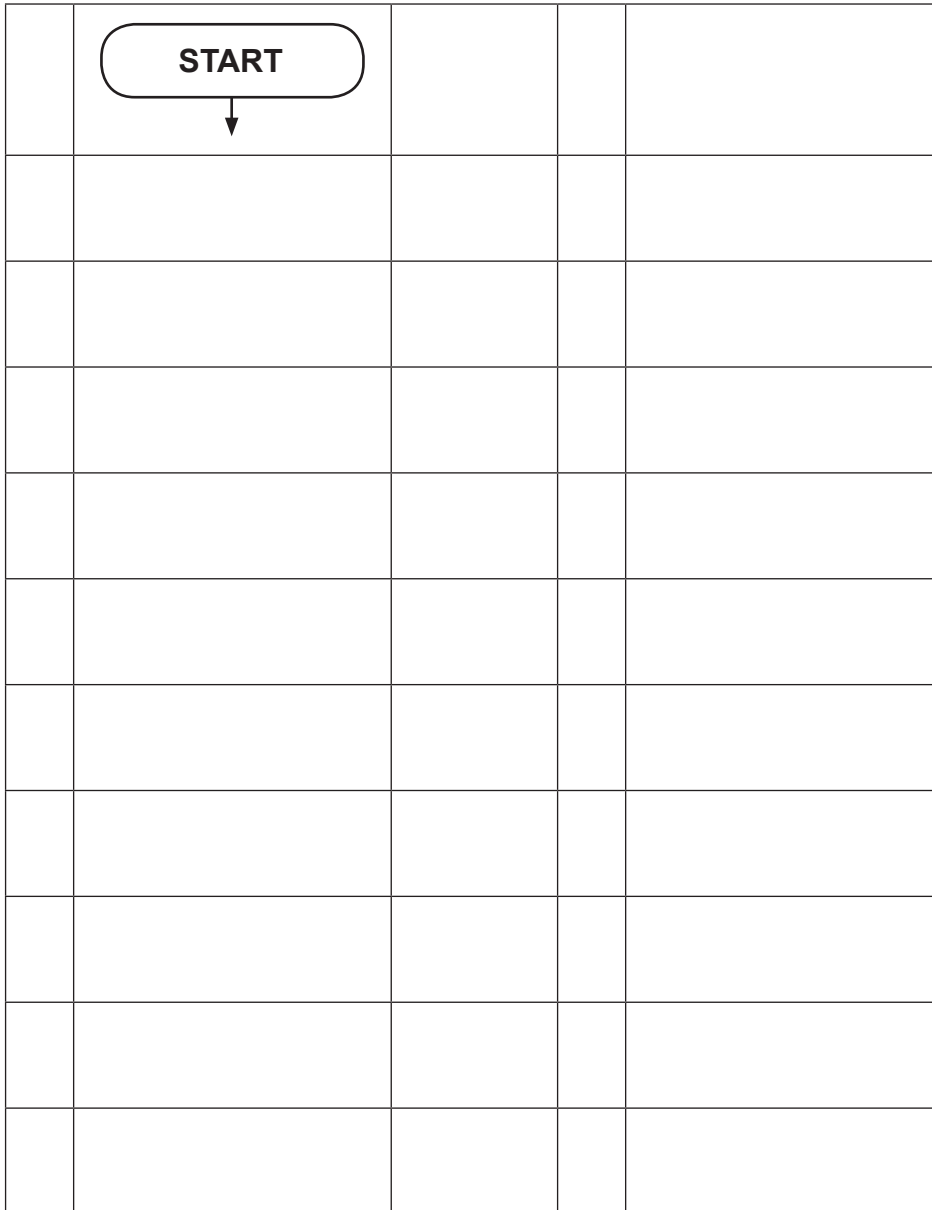

Fig. 7

[11]





BLANK PAGE
DO NOT WRITE ON THIS PAGE

9397



16GTD2115

DO NOT WRITE ON THIS PAGE

For Examiner's use only	
Question Number	Marks
1	
2	
Total Marks	

Examiner Number

Permission to reproduce all copyright material has been applied for.
In some cases, efforts to contact copyright holders may have been unsuccessful and CCEA will be happy to rectify any omissions of acknowledgement in future if notified.

177587



16GTD2116

