



Centre Number

71

Candidate Number

StudentBounty.com

General Certificate of Secondary Education
2013

Technology and Design

Unit 2:

Systems and Control

Element 2: Mechanical and
Pneumatic Control Systems

[GTD22]

MV18

FRIDAY 7 JUNE, AFTERNOON

TIME

1 hour, plus your additional time allowance.

INSTRUCTIONS TO CANDIDATES

Write your Centre Number and Candidate Number in the spaces provided at the top of this page.

Write your answers in the spaces provided in this question paper. Complete in blue or black ink only. **Do not write in pencil or with a gel pen.**

Answer **all** questions.

INFORMATION FOR CANDIDATES

The total mark for this paper is 80.

Three inserts have been provided for visual clarity (**Fig. 3**, **Fig. 4** and **Fig. 5**) for use with questions **1(c)** and **1(d)**.

Figures in brackets printed at the end of each question indicate the marks awarded to each question or part question.

BLANK PAGE

Formulae for GCSE Technology and Design

You should use, where appropriate, the formulae given below when answering questions which include calculations.

1 Gear ratio of a simple gear train = $\frac{\text{number of teeth on driven gear}}{\text{number of teeth on driver gear}}$

For a compound gear train:

Total Gear ratio = the product of the gear ratios of all the subsystems

i.e. $GR_T = GR_1 \times GR_2 \times GR_3 \dots$

2 Mechanical Advantage = $\frac{\text{Load}}{\text{Effort}}$

3 Velocity Ratio = $\frac{\text{Distance moved by effort}}{\text{Distance moved by load}}$

4 Pneumatics

Force = Pressure \times Area ($F = P \times A$)





Element 2

Mechanical and Pneumatic Control Systems

Answer **all** questions

- 1 (a) (i) **Table 1** shows the symbols for different methods of operating pneumatic valves.

Table 1

Symbol	Name of Symbol
	
	
	
	

Complete **Table 1** by inserting the correct name for each symbol from **Table 2**. [4]

Table 2

Roller
Push Button
Plunger
Lever
Pilot Air

(ii) Select the methods from **Table 2** that would be used to operate:

- A valve to confirm the position of a piston rod [1]

- A valve which is to be operated from a distance [1]

(b) **Fig. 1** shows the components used to give a time delay.

Fig. 1

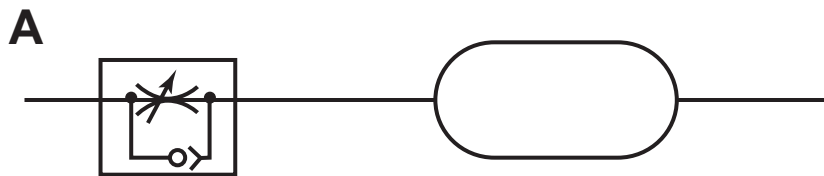

(i) Describe the function of valve **A** in the circuit. [1]

(ii) State **two** ways in which the time delay can be increased. [4]

1. _____

2. _____

(c) **Fig. 2** shows a pneumatic cylinder which is used to push heavy boxes onto a delivery chute.

Fig. 2

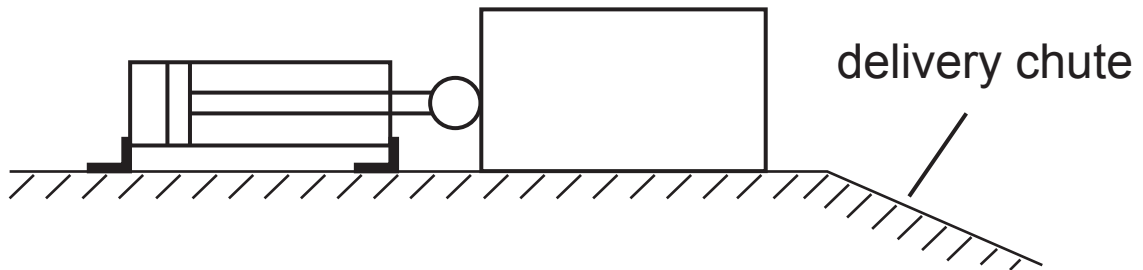

Fig. 3 (insert) shows the pneumatic circuit to control the cylinder in **Fig. 2**.

(i) State **two** factors which determine the size of the force the cylinder can exert. [2]

1. _____

2. _____

(ii) Describe briefly how the circuit operates. [3]

(iii) Explain the purpose of valve **E** in **Fig. 3**. [2]

(iv) During the building of the circuit two errors were made:

Error 1: Valve **D** was omitted as shown in **Fig. 4** (insert).
(Compare with **Fig. 3**) (insert).

Explain what happens to the supply air when button **A** is pressed. [3]

Error 2: The valve shown below was fitted in **Fig. 4** (insert) instead of valve **E**, as shown in **Fig. 3** (insert).



Explain the effect this error would have on the operation of the circuit. [3]

(d) **Fig. 5** (insert) shows part of a pneumatic circuit.

- (i) When the start button is pressed for an instant the cylinders are to move in the following sequence:
- Cylinder **A** and cylinder **B** outstroke at the same time.
 - When the **outstroke** of cylinder **B** is confirmed cylinder **A** instrokes.
 - When the **instroke** of cylinder **A** is confirmed cylinder **B** instrokes.

Complete **Fig. 5**, showing the connecting pipes and additional valves needed, for the circuit to operate in this sequence. [12]

- (ii) The circuit is to be modified so that cylinder **A** cannot instroke until the outstroke of **both** cylinders is confirmed.

Outline how this could be achieved [4]

BLANK PAGE
(Questions continue overleaf)

2 (a) **Table 3** shows four different mechanisms. Complete **Table 3** by inserting the correct name for each mechanism and the appropriate letter from the list opposite to describe its function. Each letter may be used only once. [8]

Table 3

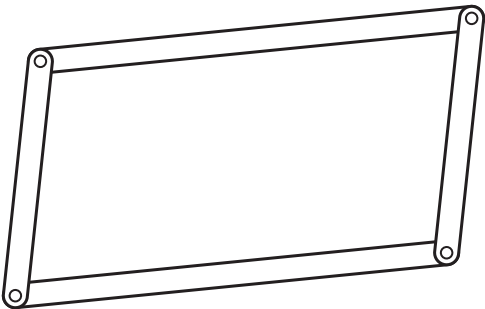
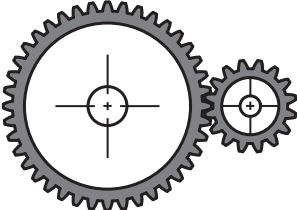
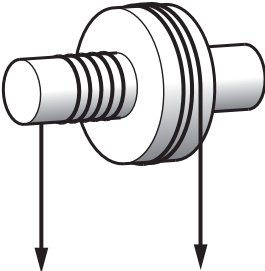
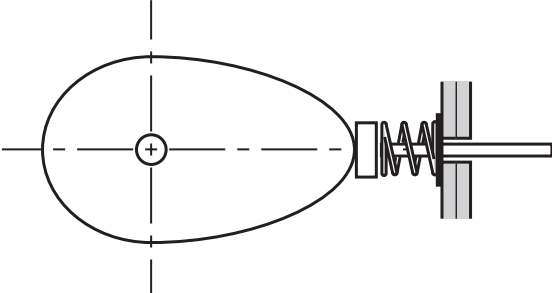
Mechanism	Name	Function
		
		
		
		

Function

- A** To transmit motion between parallel shafts.
- B** To convert rotary motion into reciprocating motion.
- C** To keep surfaces an equal distance apart as they are moved.
- D** To enable heavy loads to be raised by small efforts.

(b) Fig. 6 shows a lever used in a can crusher.

Fig. 6

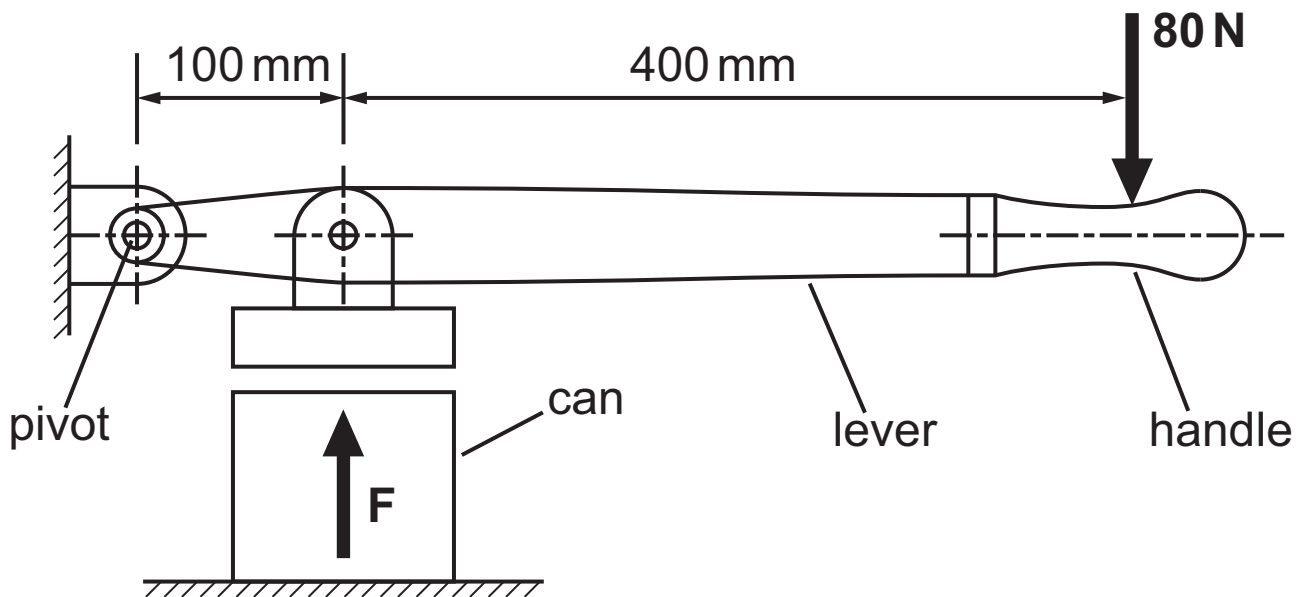

- (i) Suggest a suitable material for the lever. Give a reason for your answer. [2]

Lever material _____

Reason _____

- (ii) Calculate the force F at the can when a force of 80 N is applied to the handle. [4]

(c) (i) Name **three** types of belt and give **one** application for each type. [6]

1. _____

Application _____

2. _____

Application _____

3. _____

Application _____

(ii) Some belts can become slack. Explain why this can be a disadvantage and describe **one** method for overcoming it. [4]

Disadvantage _____

Method for overcoming _____

(iii) Fig. 7 shows a gearbox which is driven by an electric motor through a belt and pulley system.

Fig. 7

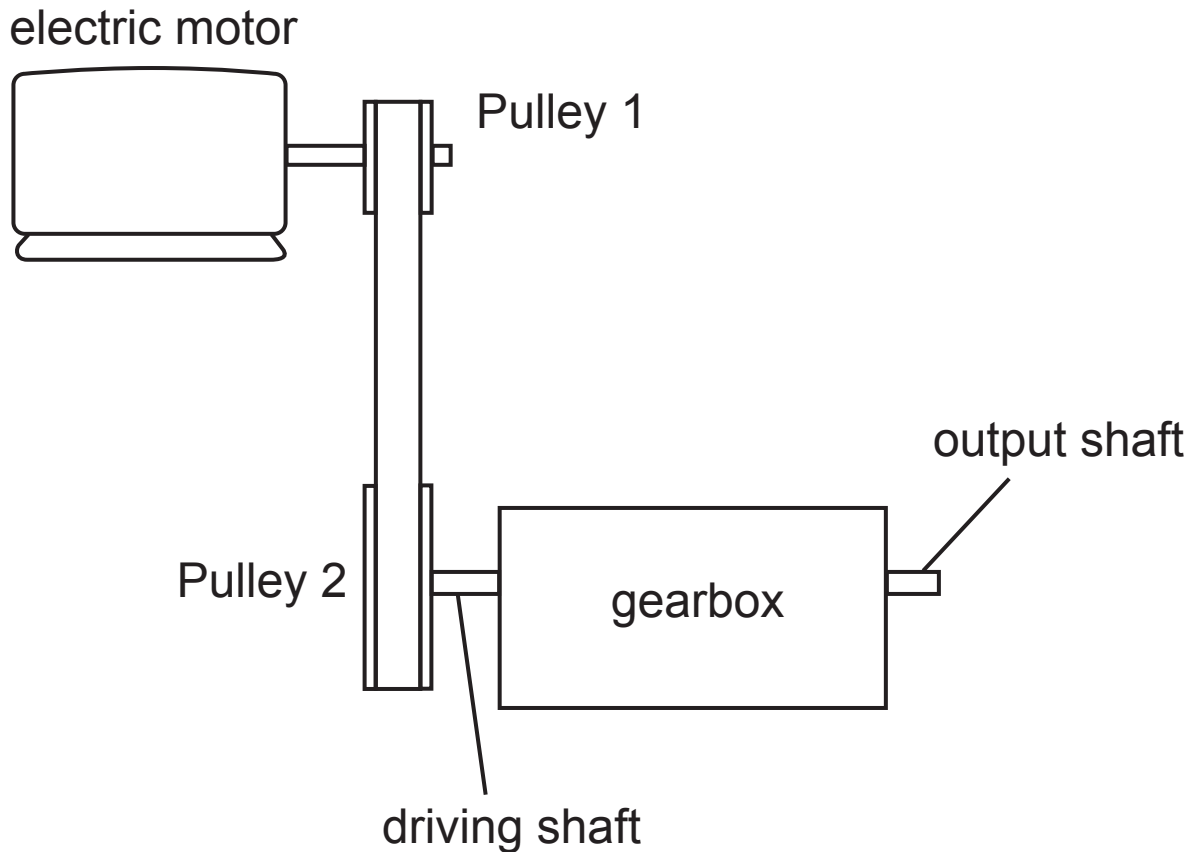

Is the speed of Pulley 1 faster or slower than Pulley 2?

Give a reason for your answer. [2]

BLANK PAGE
(Questions continue overleaf)

(d) **Fig. 8** shows the internal layout of the gearbox in **Fig. 7** where the gear wheels have the number of teeth (**T**) shown. The driving shaft rotates at 800 rev/min.

Fig. 8

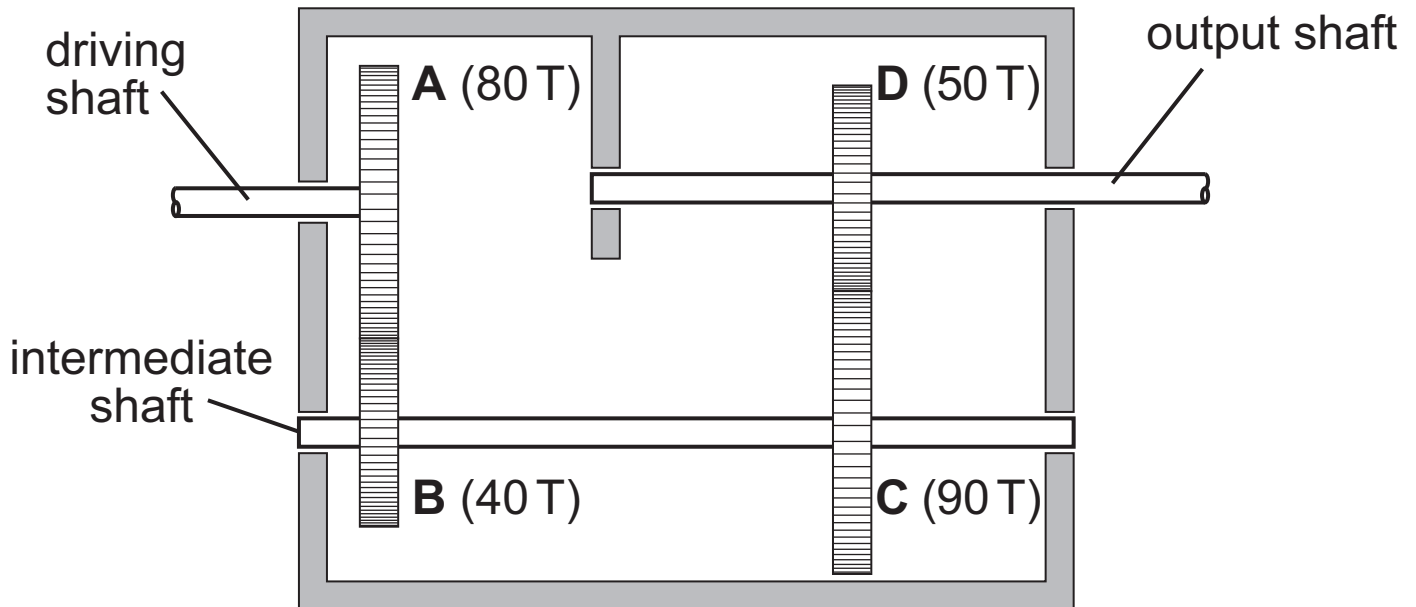

(i) State the type of gear train shown in **Fig. 8**. [2]

(ii) State **one** advantage of this type of gear train. [2]

(iii) Calculate the speed of the output shaft. [6]

(iv) The gearbox in **Fig. 8** is to be changed to give an output speed of 3200 rev/min by changing wheels **C** and **D** only. The following gear wheels are available. 30T, 45T, 60T, 75T.

Select **two** of the above wheels to replace **C** and **D** and make up a suitable drive.

Label the chosen wheels as **C** and **D**. [4]

THIS IS THE END OF THE QUESTION PAPER

For Examiner's use only	
Question Number	Marks
1	
2	
Total Marks	

Examiner Number

Permission to reproduce all copyright material has been applied for.
In some cases, efforts to contact copyright holders may have been unsuccessful and CCEA will be happy to rectify any omissions of acknowledgement in future if notified.

8117.02 **MV18**

Fig. 3 (insert) to be used with question 1(c).

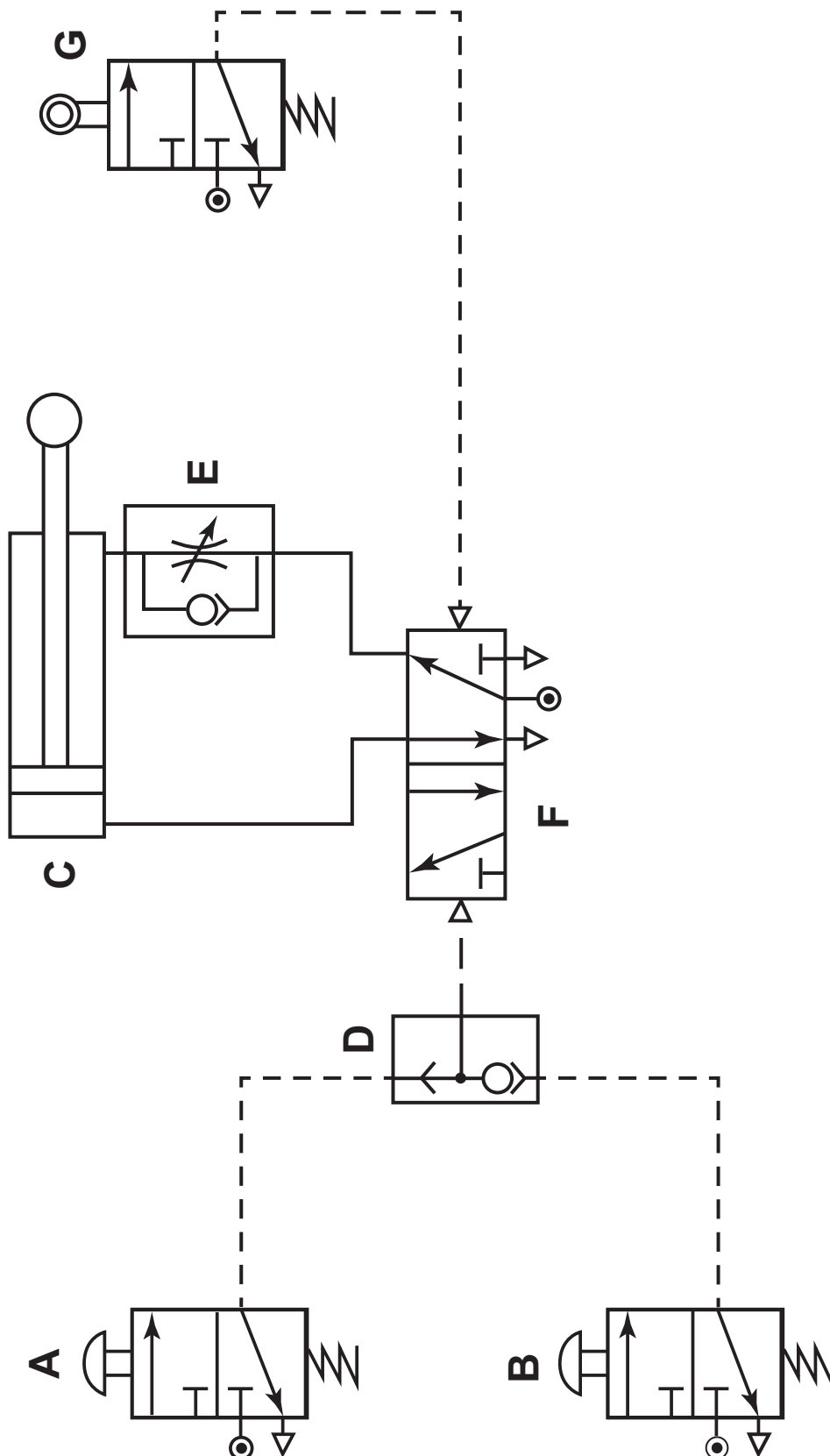

Fig. 4 (insert) to be used with question 1(c)(iv).

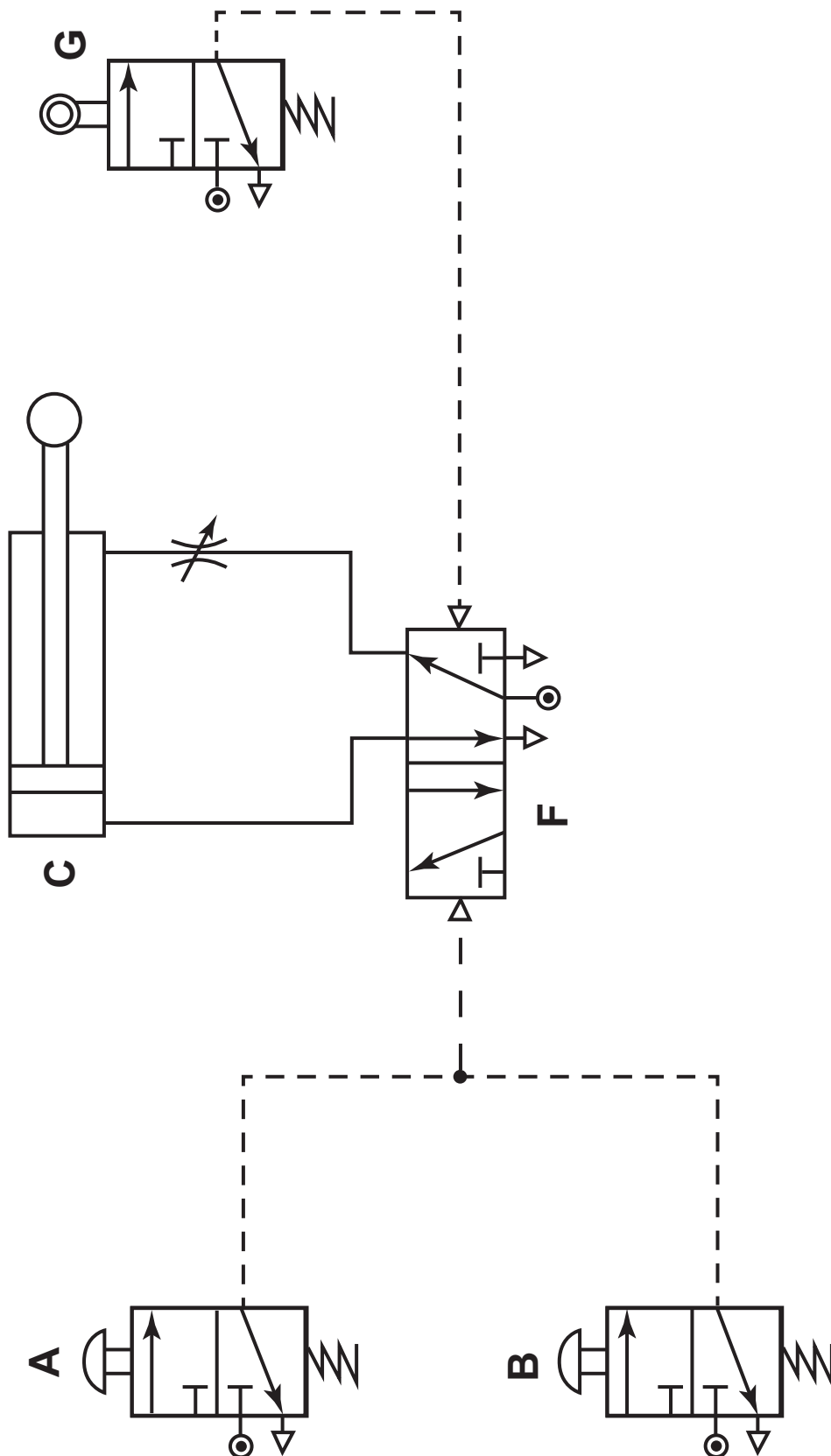

Fig. 4 (insert) to be used with question 1(c)(iv).

