



Rewarding Learning

General Certificate of Secondary Education
2012

Technology and Design

Unit 2: Systems and Control

Element 1: Electronic and Microelectronic Control Systems

[GTD21]

TUESDAY 29 MAY, AFTERNOON

StudentBounty.com

Centre Number
71

Candidate Number



TIME

1 hour.

INSTRUCTIONS TO CANDIDATES

Write your Centre Number and Candidate Number in the spaces provided at the top of this page.

Write your answers in the spaces provided in this question paper.

Answer **all** questions.

On **page 3** we have provided formulae for you to use with this paper.

INFORMATION FOR CANDIDATES

The total mark for this paper is 80.

Figures in brackets printed down the right-hand side of pages indicate the marks awarded to each question or part question.



7323

For Examiner's use only	
Question Number	Marks
1	
2	

Total Marks	
--------------------	--

BLANK PAGE

Formulae for GCSE Technology and Design

You should use, where appropriate, the formulae given below when answering questions which include calculations.

1 Potential Difference = current \times resistance ($V = I \times R$)

2 For potential divider

$$V_2 = \frac{R_2}{R_1 + R_2} \times V_T$$

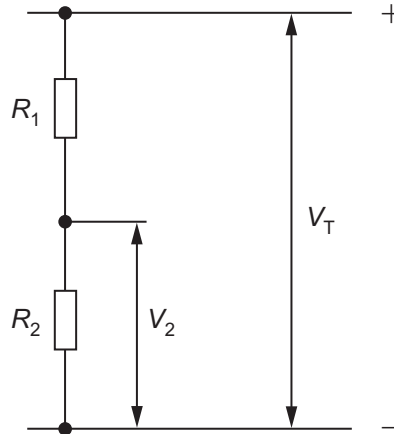

3 Series Resistors $R_T = R_1 + R_2 + R_3 \text{ etc}$

Parallel Resistors $\frac{1}{R_T} = \frac{1}{R_1} + \frac{1}{R_2}$ or $R_T = \frac{R_1 \times R_2}{R_1 + R_2}$

4 Time Constant $T = R \times C$

- 2 **Fig. 3** shows an animated display to give directions to subject areas for a school open night. The arms will move up and down as shown by the arrows labelled **A** and **B**. The LEDs will switch on and off and the disc can rotate. The display will be controlled by PIC microcontroller.

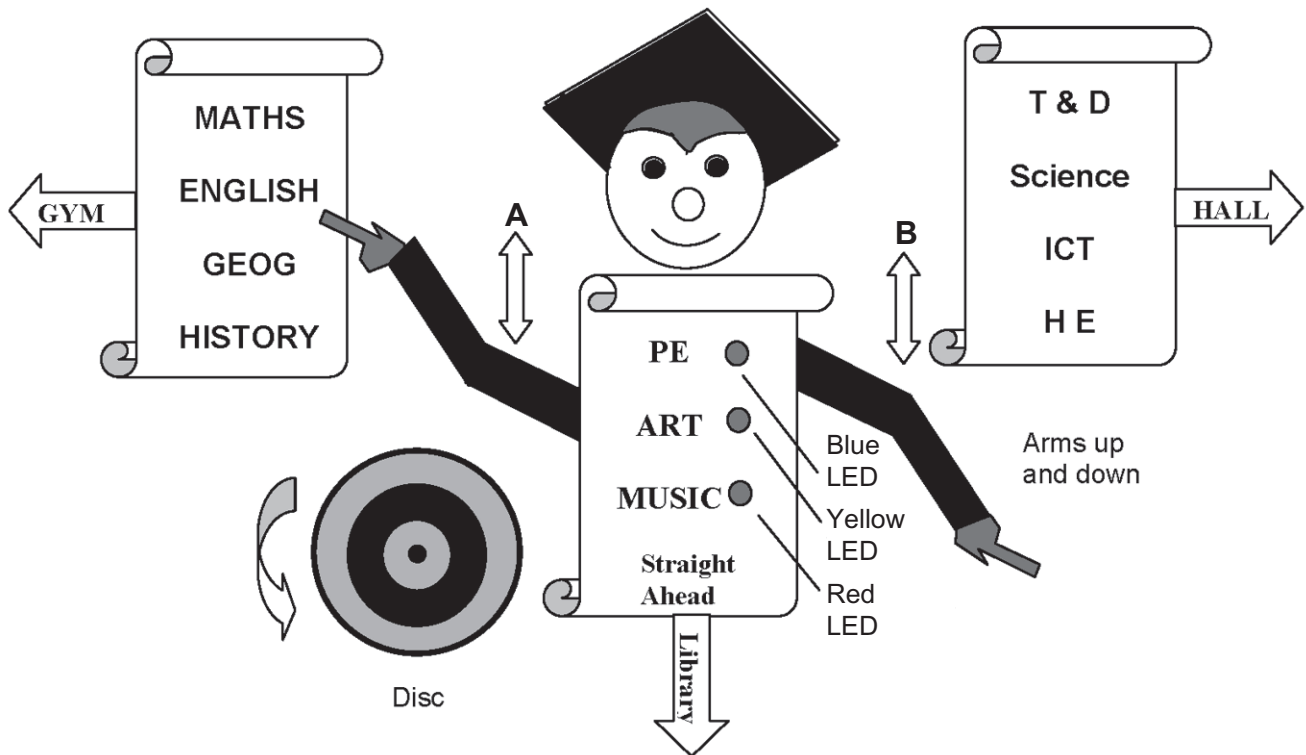

Fig. 3

Six of the eight PIC outputs and two of the PIC inputs are to be used to control the display unit. The output connections are shown in **Table 1** and the inputs are shown in **Table 2**.

Outputs 0, 1 and 2 control the LEDs to illuminate three subjects. Outputs 3 and 4 control the movement of the arms to point to groups of subjects and output 5 controls the revolving disc.

Table 1

PIC Outputs	Not used	Not used	Disc	Arm "B"	Arm "A"	Blue LED	Yellow LED	Red LED
BIT	7	6	5	4	3	2	1	0

Table 2

PIC Inputs	Not used	Not used	Switch 1	Switch 2	Not used
BIT	4	3	2	1	0

(b) A student constructs a series of flowcharts to represent the overall operation of the animated display unit in **Fig. 3**.

(i) Complete a flowchart and its relevant bit pattern in **Fig. 4** as follows:

- Switch 1 must be pressed to start the routine
- Both arms rise up
- The red and blue LEDs turn on
- All outputs turn off

[10]

	START			BIT PATTERN

Fig. 4

(ii) The student decided to improve the routine for the animated display unit. Complete the flowchart and bit pattern in **Fig. 5** as follows:

- Switch 1 is pressed to start the routine
- Arm A rises and remains in position for 3 seconds and then falls back to its original position
- The Red LED goes on for 7 seconds
- After 2 seconds the Yellow LED goes on for 5 seconds
- All LEDs turn off
- Arm B rises and remains in position for 6 seconds before falling back. During this time the disc rotates
- This routine repeats until switch 2 is pressed. If this switch is pressed the system stops.

Examiner Only	
Marks	Remark

Permission to reproduce all copyright material has been applied for.
In some cases, efforts to contact copyright holders may have been unsuccessful and CCEA
will be happy to rectify any omissions of acknowledgement in future if notified.