

Leave blank

UNOS REGALOS

¿Qué quieren estos jóvenes?

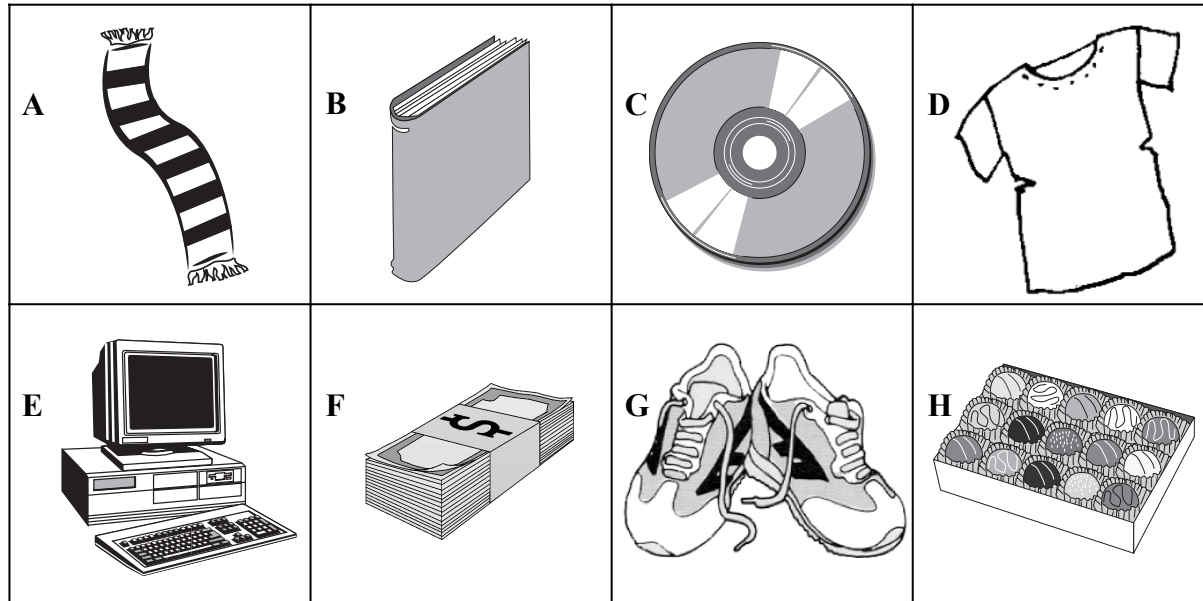

Pon la letra adecuada en cada casilla.

Ejemplo	H
1.	
2.	
3.	
4.	
5.	

Q1-5

(Total 5 marks)



Leave blank

EL FIN DE SEMANA

¿Qué dice esta persona?

Pon una equis (☒) en la casilla adecuada.

Ejemplo: Se llama.....



Javier	Antonio	José
<input checked="" type="checkbox"/>	<input checked="" type="checkbox"/>	<input checked="" type="checkbox"/>

6. Se levanta a las.....

8 :15	8 :30	8 :45
<input checked="" type="checkbox"/>	<input checked="" type="checkbox"/>	<input checked="" type="checkbox"/>

(1)

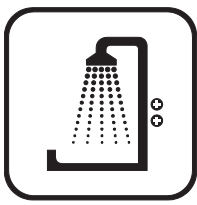
7. Por la mañana.....



		
<input checked="" type="checkbox"/>	<input checked="" type="checkbox"/>	<input checked="" type="checkbox"/>

(1)



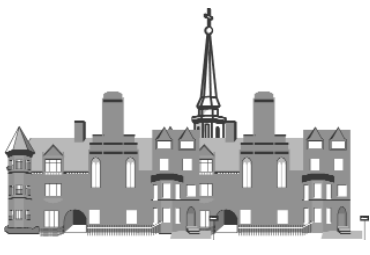

Leave blank

8. Por la tarde.....

		
<input type="checkbox"/>	<input type="checkbox"/>	<input type="checkbox"/>

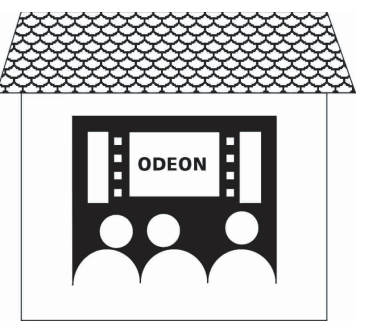

(1)

9. Le gusta.....

		
<input type="checkbox"/>	<input type="checkbox"/>	<input type="checkbox"/>

(1)

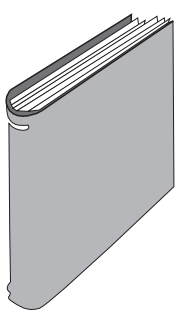
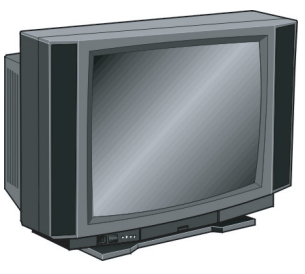
10. Por la noche.....

		
<input type="checkbox"/>	<input type="checkbox"/>	<input type="checkbox"/>

(1)

(Total 5 marks)

Q6-10



Leave blank

EL COLEGIO

Unos jóvenes hablan del colegio.

Lee los temas siguientes.

A	La cantina.
B	Las asignaturas.
C	Su profesor favorito.
D	Los alumnos.
E	Las reglas.
F	Sus planes futuros.
G	El horario.

Pon la letra adecuada en cada casilla.

Ejemplo:	Santi	B
11.	Ana	
12.	Raúl	
13.	Carla	
14.	Jorge	
15.	Inés	

(Total 5 marks)

Q11-15



Leave blank

EL PERRO PERDIDO

16. ¿Qué ha desaparecido?

Lee la pregunta siguiente.

Completa el formulario **en español**.

Detalles	
Ejemplo: Nombre	Tobi
(a) Edad : (1)
(b) Pelo : (1)
Otros detalles :	
(c)
(d)
(e) (3)

(Total 5 marks)

Q16









Leave blank

BEBIDAS FAVORITAS

¿Qué les gusta beber?

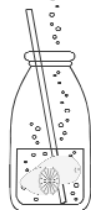
Pon una equis (☒) en las casillas adecuadas.

	A	B	C	D	E	F	G	H
Ejemplo:	 <input checked="" type="checkbox"/>	 <input checked="" type="checkbox"/>	 <input checked="" type="checkbox"/>	 <input checked="" type="checkbox"/>	 <input checked="" type="checkbox"/>	 <input checked="" type="checkbox"/>	 <input checked="" type="checkbox"/>	 <input checked="" type="checkbox"/>
17.	<input type="checkbox"/>	<input type="checkbox"/>	<input type="checkbox"/>	<input type="checkbox"/>	<input type="checkbox"/>	<input type="checkbox"/>	<input type="checkbox"/>	<input type="checkbox"/>
18.	<input type="checkbox"/>	<input type="checkbox"/>	<input type="checkbox"/>	<input type="checkbox"/>	<input type="checkbox"/>	<input type="checkbox"/>	<input type="checkbox"/>	<input type="checkbox"/>
19.	<input type="checkbox"/>	<input type="checkbox"/>	<input type="checkbox"/>	<input type="checkbox"/>	<input type="checkbox"/>	<input type="checkbox"/>	<input type="checkbox"/>	<input type="checkbox"/>
20.	<input type="checkbox"/>	<input type="checkbox"/>	<input type="checkbox"/>	<input type="checkbox"/>	<input type="checkbox"/>	<input type="checkbox"/>	<input type="checkbox"/>	<input type="checkbox"/>
21.	<input type="checkbox"/>	<input type="checkbox"/>	<input type="checkbox"/>	<input type="checkbox"/>	<input type="checkbox"/>	<input type="checkbox"/>	<input type="checkbox"/>	<input type="checkbox"/>

(Total 5 marks)

Q17-21



7

Turn over

Leave
blank

LA MODA

22. Chus habla de la moda.

¿Qué dice?

Pon una equis (☒) en las 5 casillas apropiadas.

Ejemplo: Se llama Chus	<input checked="" type="checkbox"/>
(a) La moda no le importa	<input type="checkbox"/>
(b) La moda es muy importante	<input type="checkbox"/>
(c) La moda es cara	<input type="checkbox"/>
(d) La moda no cambia nunca	<input type="checkbox"/>
(e) Prefiere el color rojo	<input type="checkbox"/>
(f) Le gusta ser diferente	<input type="checkbox"/>
(g) Su estilo es único	<input type="checkbox"/>
(h) Lleva una falda	<input type="checkbox"/>
(i) Los pantalones no son cómodos	<input type="checkbox"/>
(j) Le gusta la ropa deportiva	<input type="checkbox"/>

Q22

(Total 5 marks)



BLANK PAGE



EL VIAJE

23. (a) Pilar habla de un viaje escolar.

Lee las preguntas siguientes.

Pon una equis (☒) en las casillas apropiadas.

Ejemplo: Fue a ...

Madrid	A	☒
Barcelona	B	☒
Sevilla	C	☒

(i) Pasó ...

un fin de semana	A	☒
una semana	B	☒
dos semanas	C	☒

(ii) Salió ...

temprano	A	☒
al mediodía	B	☒
después de las clases	C	☒

(iii) El viaje fue ...

aburrido	A	☒
largo	B	☒
caro	C	☒



(b) (i) Visitó ...

catedrales

A

museos

B

playas

C

(ii) También fue ...

de compras

A

de excursión

B

a nadar

C

Leave
blank

Q23

(Total 5 marks)



Leave blank

LA CLASE DE ESPAÑOL

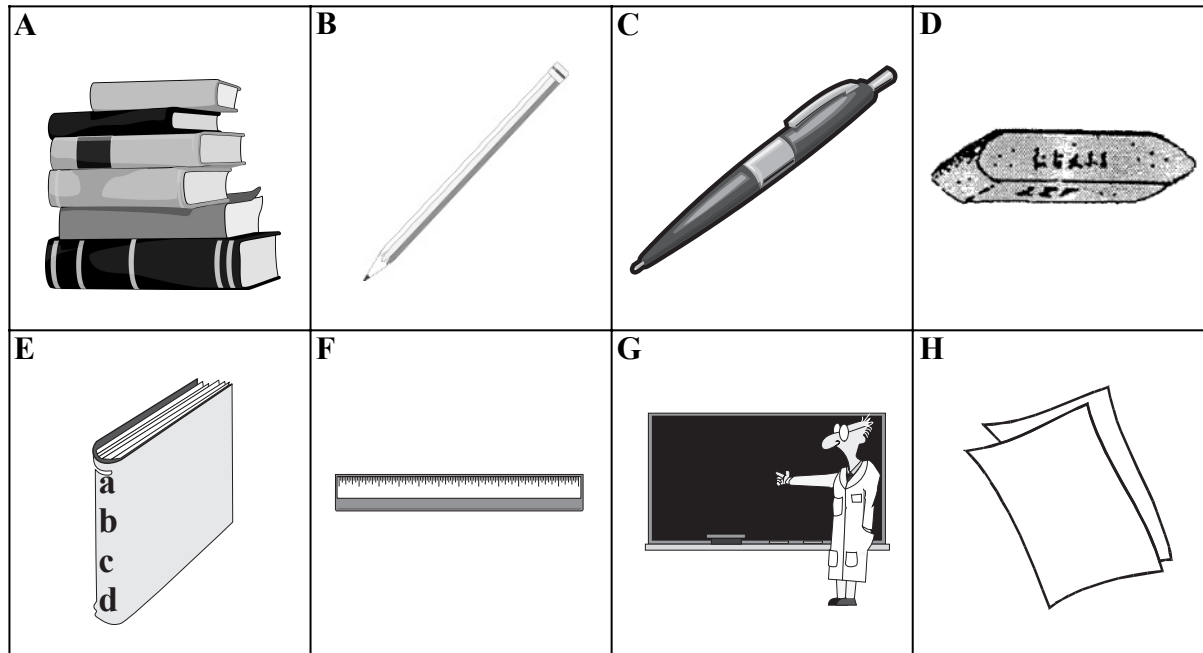

Pon la letra adecuada en cada casilla.

Ejemplo:	G
24.	
25.	
26.	
27.	
28.	

Q24-28

(Total 5 marks)



Leave blank

ECO SCHOOLS

Tito is talking about his school project.

Read the following questions.

Make notes for your own school project.

Answer the questions **in English**.

29. (i) When did this project begin?

.....
(1)

(ii) What did Tito have to do?

.....
(1)

(iii) What was the prize?

.....
(1)

(Total 3 marks)

Q29

30. (i) What area of the school was targeted?

.....
(1)

(ii) What did they stop selling?

.....
(1)

(Total 2 marks)

Q30



Leave blank

A PART TIME JOB

You hear this announcement on the local radio about a part time job.

Read the following questions.

Make notes of the details for your Spanish friend.

Answer the questions **in English**.

31. (i) When is the job for?

.....
(1)

(ii) How old do you have to be?

.....
(1)

(iii) What abilities do you need?

.....
(1)

(Total 3 marks)

Q31

32. What should you do if you are interested?

.....and

.....

(Total 2 marks)

Q32

TOTAL FOR PAPER: 50 MARKS

END



BLANK PAGE



BLANK PAGE

