

Surname	Centre Number	Candidate Number
Other Names		0



GCSE

4461/01



W15-4461-01

SCIENCE A/BIOLOGY

**BIOLOGY 1
FOUNDATION TIER**

A.M. WEDNESDAY, 7 January 2015

1 hour

For Examiner's use only		
Question	Maximum Mark	Mark Awarded
1.	6	
2.	5	
3.	7	
4.	9	
5.	4	
6.	5	
7.	6	
8.	6	
9.	6	
10.	6	
Total	60	

ADDITIONAL MATERIALS

In addition to this paper you may require a calculator and a ruler.

INSTRUCTIONS TO CANDIDATES

Use black ink or black ball-point pen.

Write your name, centre number and candidate number in the spaces at the top of this page.

Answer **all** questions.

Write your answers in the spaces provided in this booklet.

INFORMATION FOR CANDIDATES

The number of marks is given in brackets at the end of each question or part-question.

You are reminded that assessment will take into account the quality of written communication used in your answer to question **10**.

Answer all questions.

1. (a) The table below shows changes in the populations of some farmland birds between 1980 and 2010.

bird	population (millions)		percentage fall (%)
	1980	2010	
Starling	85	40	53
Sparrow	53	25	53
Linnet	37	15	59
Dove	13	4	69
Bunting	6	1	83

- (i) Which bird had the greatest **percentage** fall? [1]

.....

- (ii) Which bird had the greatest fall in **population**? [1]

.....

- (b) The diagram shows land use on a farm in 1980 and in 2010.

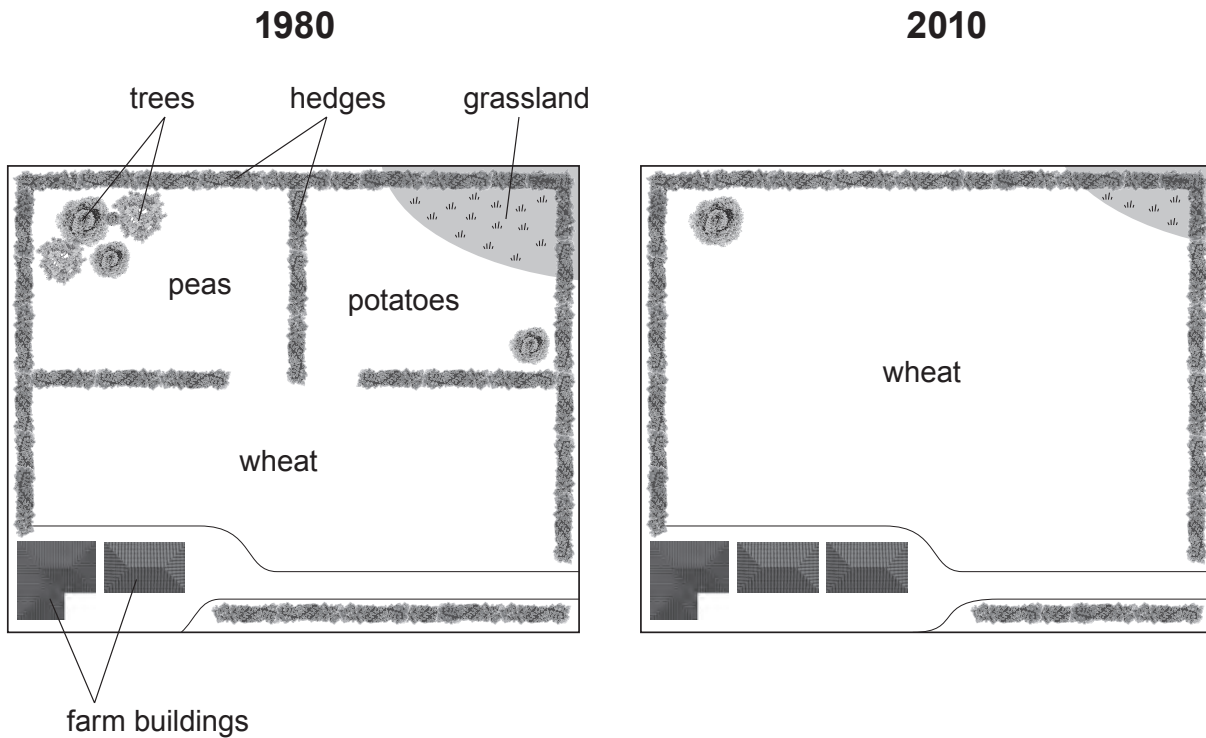

(i) The farmer cut down most of the trees in 1981.

From the diagram, give **two other** changes to land use on the farm that affected the farmland birds. [2]

1

2

(ii) The farmer will plant more trees on his farm next year.

Suggest **two** ways that trees help birds to live on the farm. [2]

1

2

6

2. Classification of the cow (*Bos taurus*) and a part classification of the horse (*Equus ferus*) are shown in the box below.

Cow		Horse	
Kingdom	Animal	Kingdom	Animal
Phylum	Vertebrates	Phylum
Class	Mammals	Class	Mammals
Genus	<i>Bos</i>	Genus
Species	<i>taurus</i>	Species

- (a) Complete the classification of the horse in the box above. [3]

- (b) In 2013, scientists made genetic profiles of meat taken from some beef burgers.

- (i) State the chemical that is studied in a genetic profile.

.....

[1]

- (ii) Two *different* genetic profiles were found. The scientists then concluded that the beef burgers had meat from cows **and** horses.

Complete the following sentence by underlining the correct word.

[1]

The samples had two different genetic profiles because they contained meat from animals of two different **herds / breeds / species**.

3. The table below lists some human conditions and their causes.

(a) Complete the table by placing a tick (✓) in each row to show a possible cause of each condition. *The first row has been done for you.* [3]

condition	cause			
	bacteria	excess alcohol	excess energy in food	excess salt in food
high blood pressure				✓
infection				
drug dependence				
obesity				

(b) Which of the above conditions may be treated by:

(i) antibiotics; [1]

(ii) reduced fat in the diet? [1]

(c) Cystic fibrosis is a disease that affects the lungs.

Why do people with cystic fibrosis have difficulty breathing? [2]

.....

.....

.....

4. The drawing shows some water plants called Duckweed (*Lemna minor*).



Students investigated the effect of nitrate on the numbers of living Duckweed plants growing in beakers as shown below.

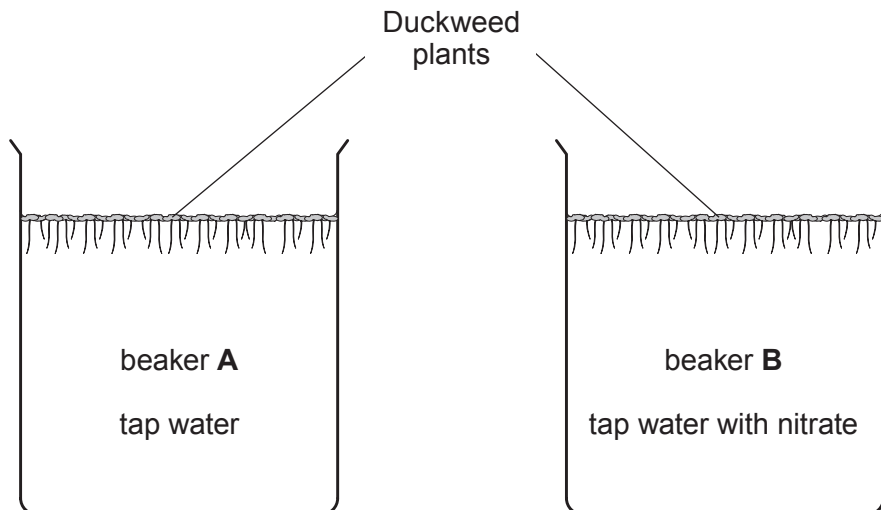

The results are shown in the table below.

day	number of living plants	
	beaker A	beaker B
1	100	100
2	120	140
3	160	180
4	180	280
5	200	360
6	210	340
7	220	300

(a) Complete the graph below to show the changes in the number of living plants in beaker **B** by:

(i) plotting the points; [2]

(ii) joining the points with a ruler. [1]

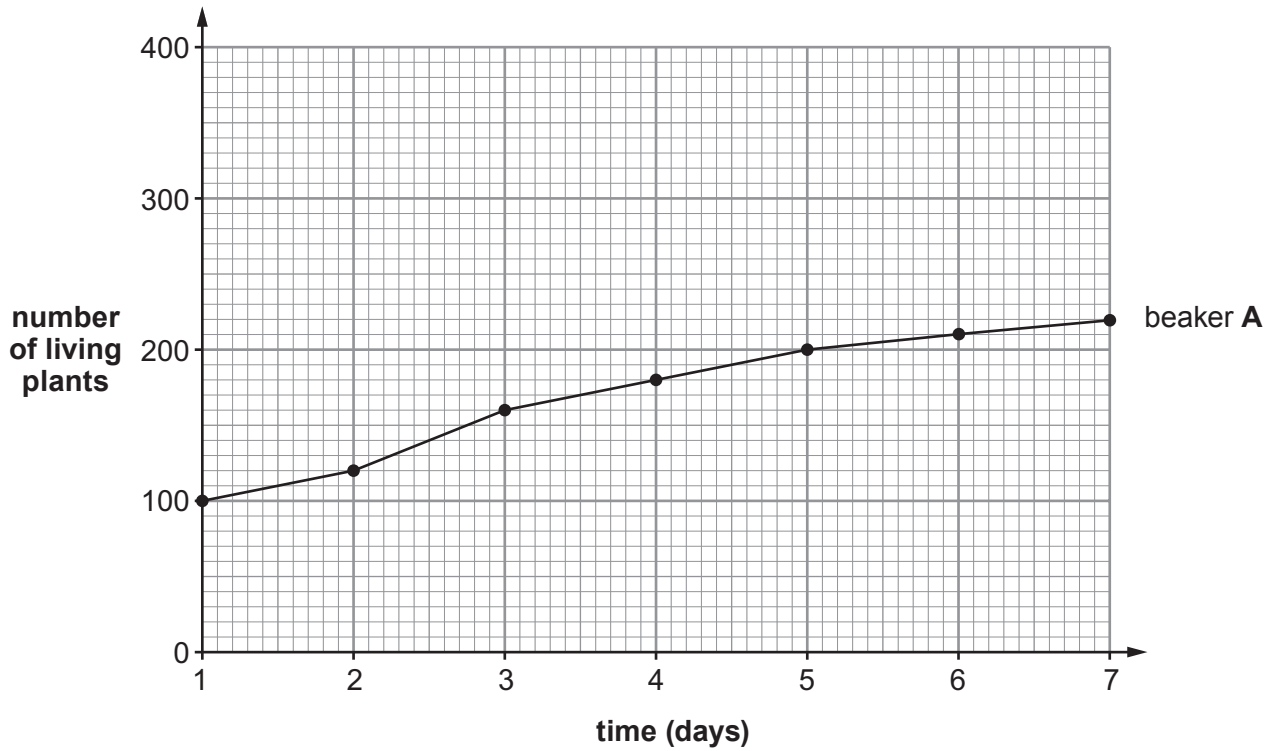

(iii) From the graph, describe the changes in the number of living plants in beaker **B** between days **1** and **7**. [1]

.....

.....

(b) The results in beaker **A** (the control) allow a comparison to be made with the results in beaker **B**.

Why is it necessary to compare the results in this investigation? [1]

.....

(c) The diagrams show the plants in beaker **B** during the investigation.

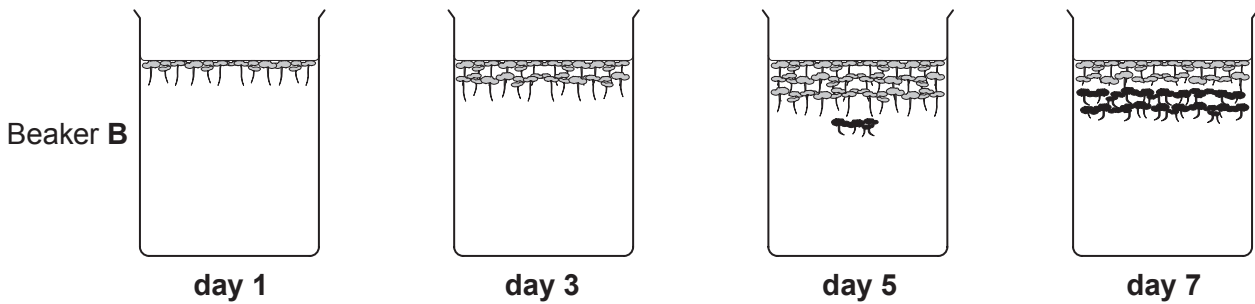

Key		living plants
		dead & decaying plants

(i) From the diagram above, on which day (1, 3, 5 or 7):

I is the level of dissolved oxygen in the water lowest?

Day [1]

II are the number of bacteria in the water highest?

Day [1]

(ii) Explain why the level of dissolved oxygen in beaker **B** changes during the investigation. [2]

.....

5. (a) A human body cell has 46 chromosomes.

How many chromosomes are in an **egg** cell?

[1]

(b) Male body cells have XY chromosomes. Female body cells have XX chromosomes.

Complete the diagram below to show how sex is inherited in humans by:

(i) completing the gametes present;

[1]

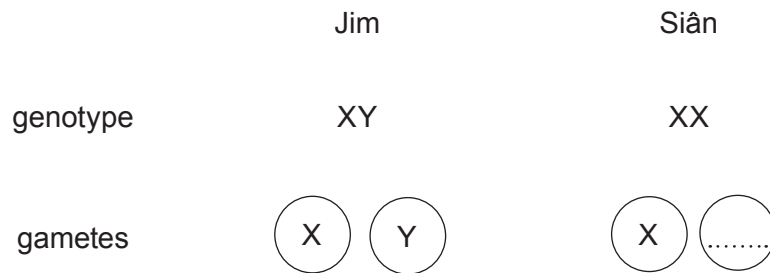

(ii) completing the Punnett square.

[2]

	Siân	
Jim	X	
X	XX	

6. The diagram shows an active sweat gland in the skin on a hot day.

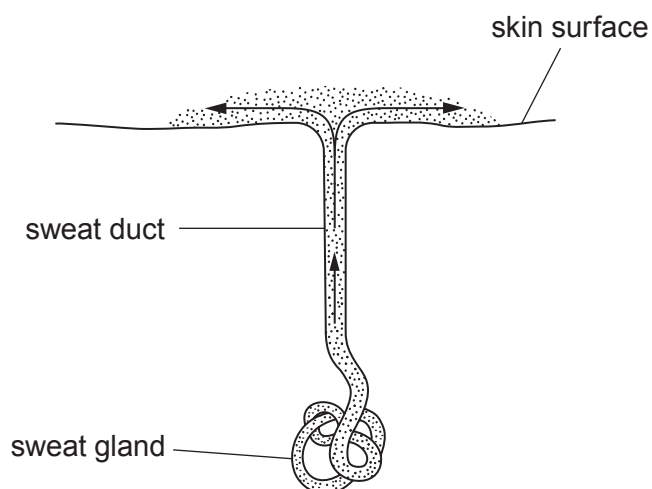

- (a) Use the structures named in the diagram above to describe the processes taking place. [2]

.....

.....

.....

.....

- (b) The diagram below shows sun cream spread on the skin surface.

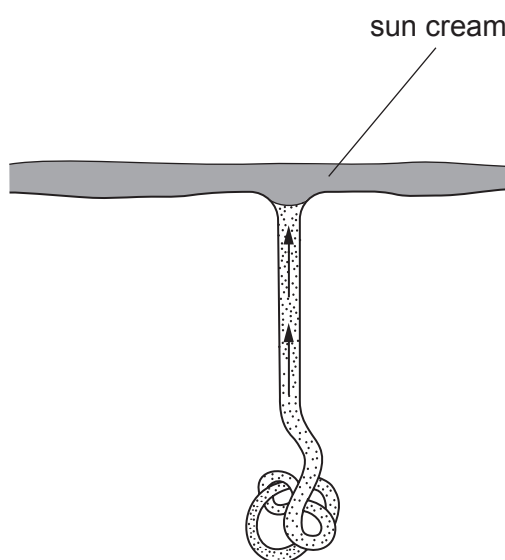

Use the information in **both** diagrams opposite to describe and explain how sun cream affects temperature control. [3]

Examiner
only

.....

.....

.....

.....

.....

.....

5

7. The diagram below shows the pyramid of numbers for a food chain found in a small wood.

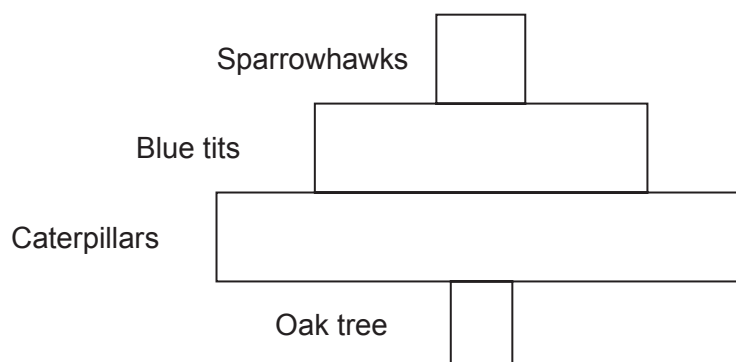

- (a) (i) Show the correct relationship in the food chain by adding **one** of the following numbers to **each** of the feeding levels in the above pyramid of numbers. [1]

1 17 3456 2

- (ii) I In the space below draw a **labelled** pyramid of biomass for this food chain. [1]

- II Show the correct relationship in the food chain by adding **one** of the following masses to **each** of the feeding levels in **your pyramid** of biomass shown in a(ii)I. [1]

0.18 kg 5137 kg 1.2 kg 43 kg

- (b) Use the information on the opposite page and your own knowledge to complete the following diagram. [2]

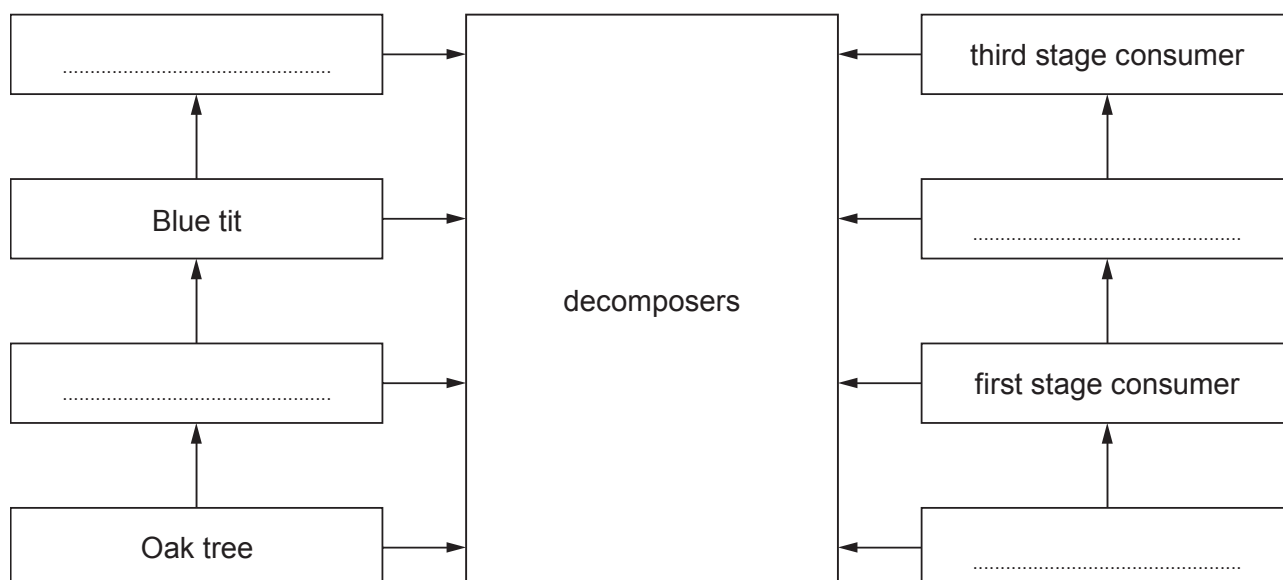

- (c) In which of the following do **all** of the processes **add** carbon dioxide to the air? Underline the correct answer. [1]

- (i) decomposition and respiration and photosynthesis
- (ii) decomposition and respiration and photosynthesis and combustion
- (iii) respiration and combustion and photosynthesis
- (iv) respiration and combustion and decomposition

8. Rhys used the apparatus shown below to find the energy in a piece of food.

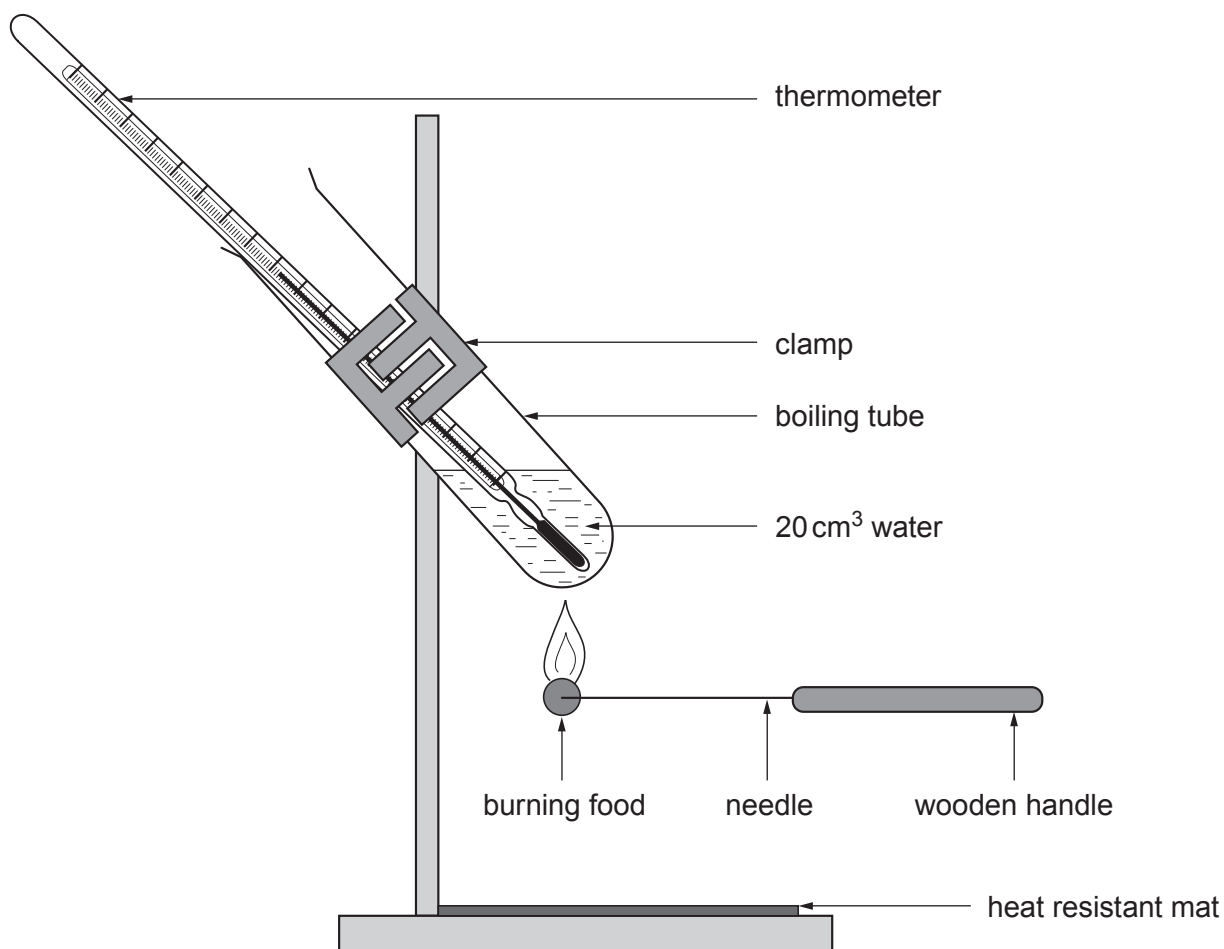

- (a) The first time Rhys carried out the experiment he obtained the following results.

initial temperature of water (°C)	final temperature of water (°C)
19	35

- (i) Use the formula below to calculate the energy content of this piece of food. Show your working. [2]

Energy content (J) = rise in temperature (°C) x volume of water (cm³) x 4.2

Energy content J

- (ii) The mass of this piece of food was 0.2 g. Calculate the energy content of 1 g of this food. [1]

Energy content J

Rhys repeated the experiment and obtained the following results.

repeat	energy content of food (J/g)
1	5049
2	7260
3	6800
4	4896
5	5724

- (b) Suggest **three** possible reasons why the measured energy content in J/g of the food differed each time Rhys carried out the experiment. [3]

(i)

(ii)

(iii)

BLANK PAGE

9. Intensive farming methods use very large amounts of chemical pesticides to increase crop yields.

The Western flower thrips (*Frankliniella occidentalis*) is an insect which eats crops, including fruit and vegetables, causing world-wide damage.



A Western flower thrips

Scientists at Swansea University have done research into pest control using bacteria which naturally live only in the thrips. The bacteria affect a gene which controls eating in the thrips. The thrips stops feeding and dies. The bacteria pass naturally between the thrips.

- (a) Use the information above to suggest **one** advantage to the farmer of using this new method of pest control over the use of chemical pesticides. [1]

.....
.....

- (b) Apart from the use of pesticides state **one other** method farmers use to increase crop yields. [1]

.....
.....

- (c) DDT is a powerful insecticide which was extensively sprayed onto crops in the middle part of the twentieth century. Its use is now banned in many regions of the world because it resulted in the death of many top predators. One of the top predators affected was the American Bald Eagle (*Haliaeetus leucocephalus*) whose numbers in the USA dropped to only 834 in 1963.

The food chain below shows the concentration of DDT in ppm (parts per million) in the tissues of the organisms in a food chain.

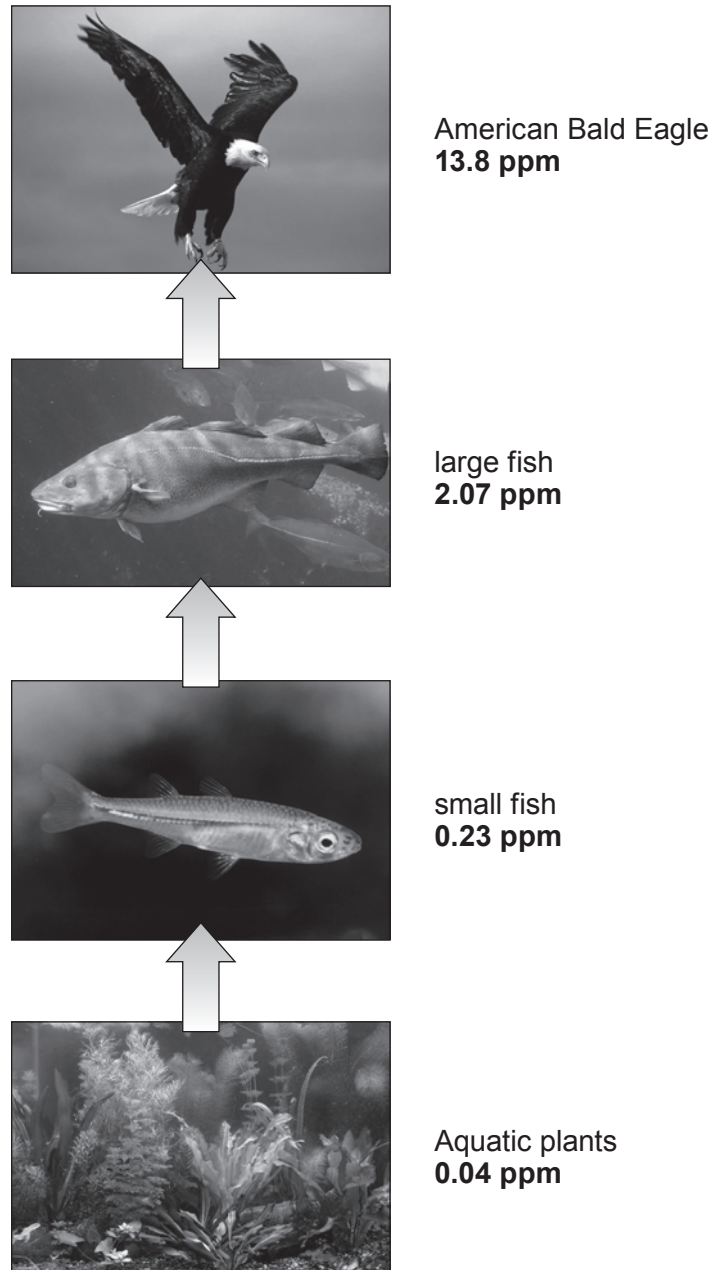

The graph below shows the number of breeding American Bald Eagles in Florida between 1942 and 1959.

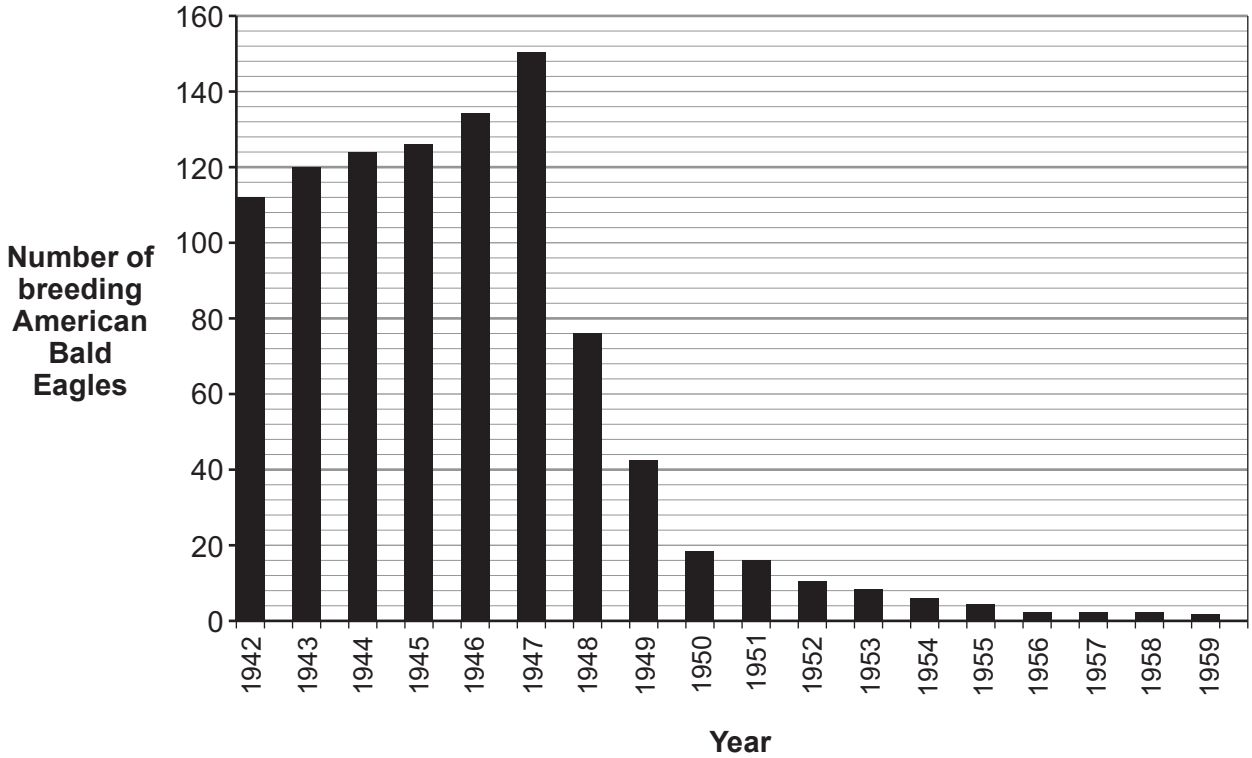

(i) From the graph, suggest the year in which DDT was first used in Florida as an insecticide. [1]

.....

(ii) Suggest why DDT is found in the aquatic plants if it is only sprayed onto crops grown on land. [1]

.....
.....

(iii) The aquatic plants and fish are not killed by the DDT but the American Bald Eagle is. Explain the reason for this. [2]

.....
.....
.....
.....

