



GCSE

4781/03

SCIENCE B

UNIT 1: Space, Energy and Life

**Pre-Release Article for use in the following
examinations on 6 June 2014:**

GCSE Science B foundation tier (4781/01)

GCSE Science B higher tier (4781/02)

4781
030001

Information for Teachers

The pre-release sets the scene for the questions in **Section B** of the foundation tier and **Section A** of the higher tier. Questions will be based around pre-release and related specification content. There will be an emphasis on data handling/analysis in this section. The questions on the pre-release will be common between the two tiers. These questions will be worth 24 marks.

No recall or terminology is required over and above that in the specification.

Students will be expected to have discussed and studied the article together with relevant specification content prior to the examination. However, they will not be expected to memorise any part of it as a clean copy will be provided with the examination paper.

Pre-Release Article – Home Insulation

Diagram 1 shows three houses of identical size. None of the houses are fully insulated.

Diagram 1 also shows how much heat is lost per second from the windows, walls and roof of each house when there is a temperature difference of 20 °C between the inside and the outside.

Diagram 1

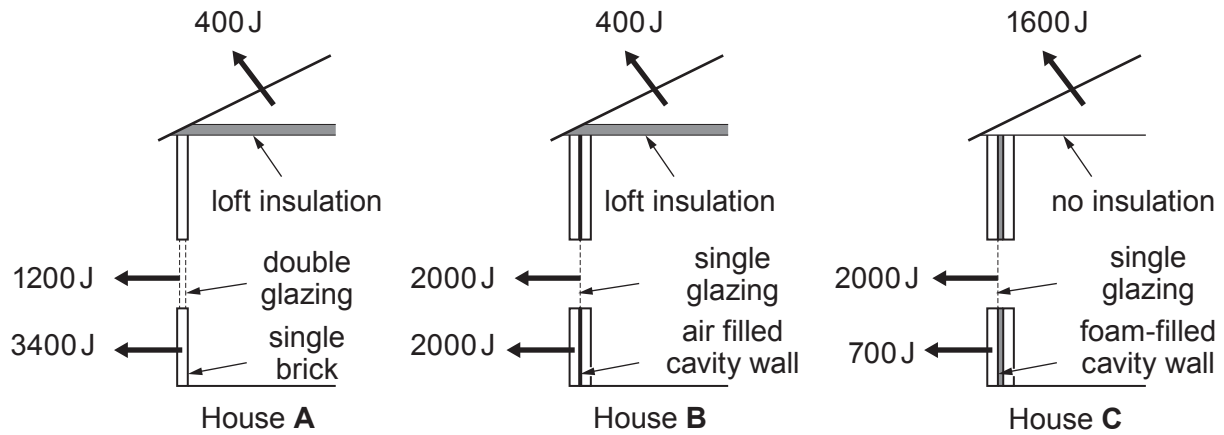

The cost of each type of insulation is shown in **Table 1** below.

Table 1

Type	Cost (£)
Loft	250
Double-glazing	4 000
Cavity wall insulation	1 200

Double glazing

The graph shows the results of an investigation to see how the rate of loss of energy through a double glazed window is affected by the width of the air gap between the two panes of glass. The investigation used a window of area 1 m^2 and kept a temperature difference of 20°C between the inside and the outside.

Graph 1

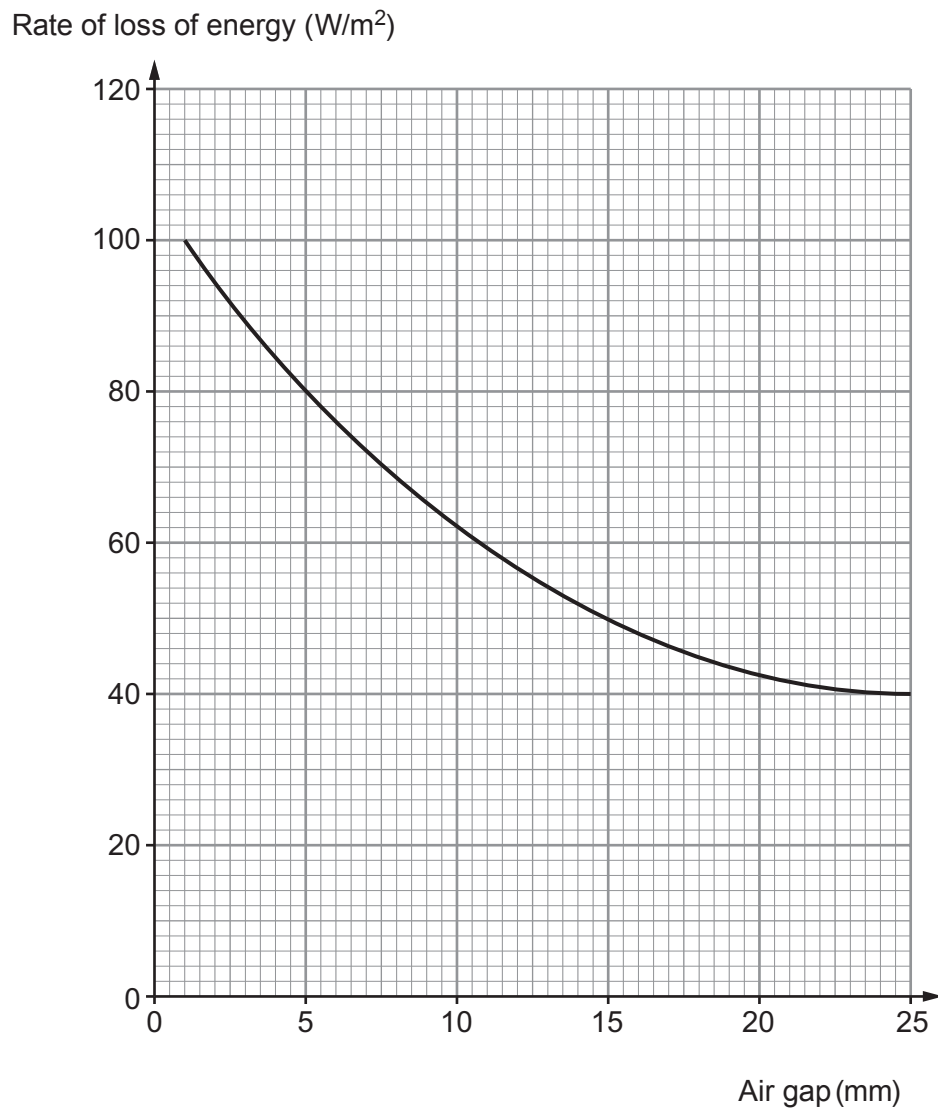

Cavity walls

Diagram 2 shows how a house wall is built. Its cavity is totally filled with foam.

Diagram 2

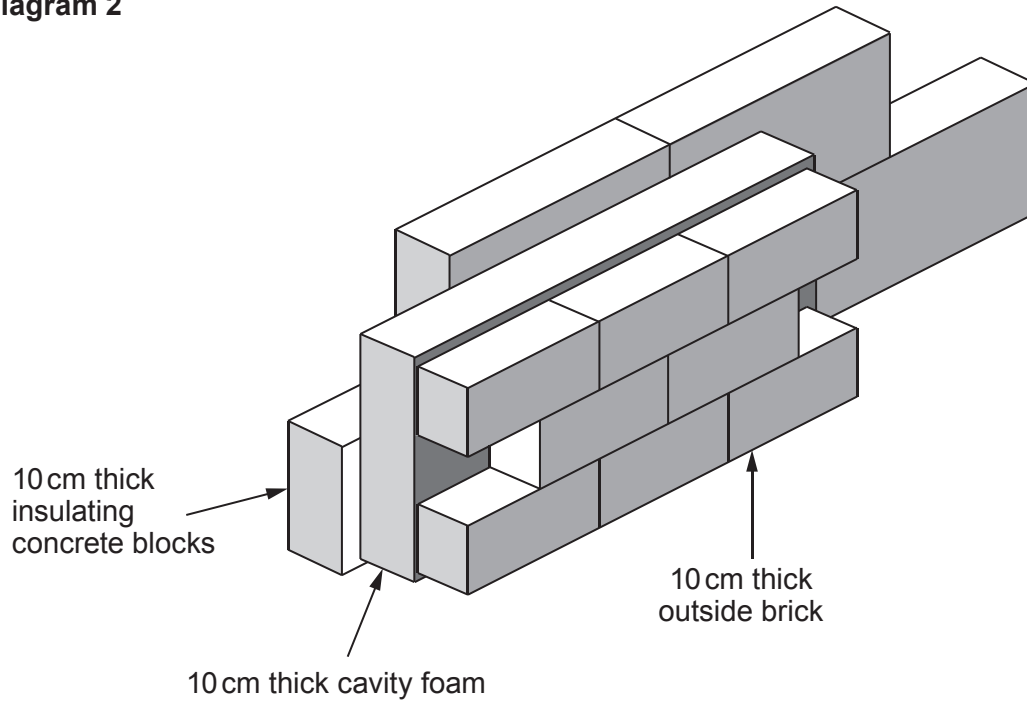

The insulating effectiveness of a material is given by a quantity called its R value.

R value is a measure of thermal resistance. The higher the R value of any material, the better its ability to resist the transmission of heat.

The R values for some common materials are shown in **Table 2** below. R values add together to give the total R value.

Table 2

Material	R value (Units)
A standard brick of thickness 10 cm	0.32
10 cm cavity wall insulating foam	3.60
10 cm thick insulating concrete block	2.08

Loft insulation

A **U value** tells us how much energy passes through a material per second.

It tells us the energy per second per square metre for a 1 °C temperature difference between the inside and the outside.

A U value of 1.61 means that 1.61 Joules of energy per second are transferred through 1 square metre of the material if the temperature difference between inside and outside is 1 °C.

U values are calculated using:

$$U = \frac{1}{R}$$

Modern regulations require that the heat loss through a roof should be limited so the U value is no more than 0.16 W/m²°C.

Table 3 shows how the U value varies with different thicknesses for two materials, **A** and **B**.

Table 3

Insulation Thickness	U value for A W/m ² °C	U value for B W/m ² °C
100 mm	0.30	0.20
120 mm	0.26	0.19
140 mm	0.23	0.17
160 mm	0.20	0.15
180 mm	0.18	0.14
200 mm	0.16	0.13

Making the most of our energy

The heat loss per second depends on the temperature difference between the inside and outside of the house.

To keep a house at a constant temperature, the energy losses must be balanced by energy produced by the heating system.

Electricity is convenient because it can be used in many ways including providing heating.

Power can be found using the equation:

$$\text{Power} = \frac{\text{energy}}{\text{time}}$$

The cost of electrical heating can be found using the equations:

$$\text{Units used} = \text{power (kW)} \times \text{time (h)}$$

$$\text{Total cost} = \text{cost of one unit} \times \text{units used}$$



GCSE

4781/03-A

SCIENCE B

UNIT 1: Space, Energy and Life

P.M. FRIDAY, 6 June 2014

Resource folder (Pre-Release Article)

For use with:

Section B of the foundation tier

Section A of the higher tier

4781
03A001

Pre-Release Article - Home Insulation

Diagram 1 shows three houses of identical size. None of the houses are fully insulated.

Diagram 1 also shows how much heat is lost per second from the windows, walls and roof of each house when there is a temperature difference of 20°C between the inside and the outside.

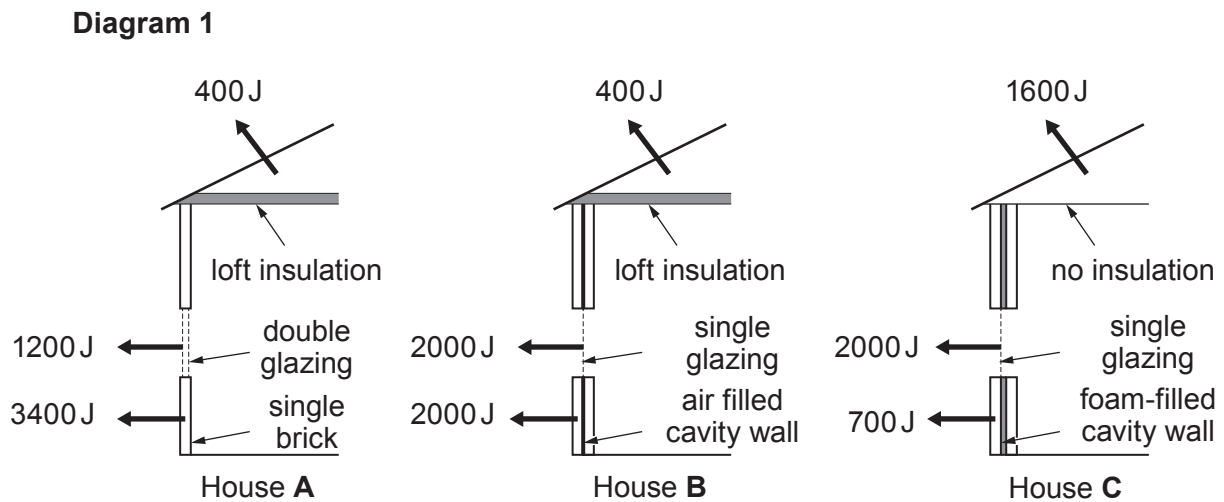

The cost of each type of insulation is shown in **Table 1** below.

Table 1

Type	Cost (£)
Loft	250
Double-glazing	4 000
Cavity wall insulation	1 200

Double glazing

The graph shows the results of an investigation to see how the rate of loss of energy through a double glazed window is affected by the width of the air gap between the two panes of glass. The investigation used a window of area 1 m^2 and kept a temperature difference of 20°C between the inside and the outside.

Graph 1

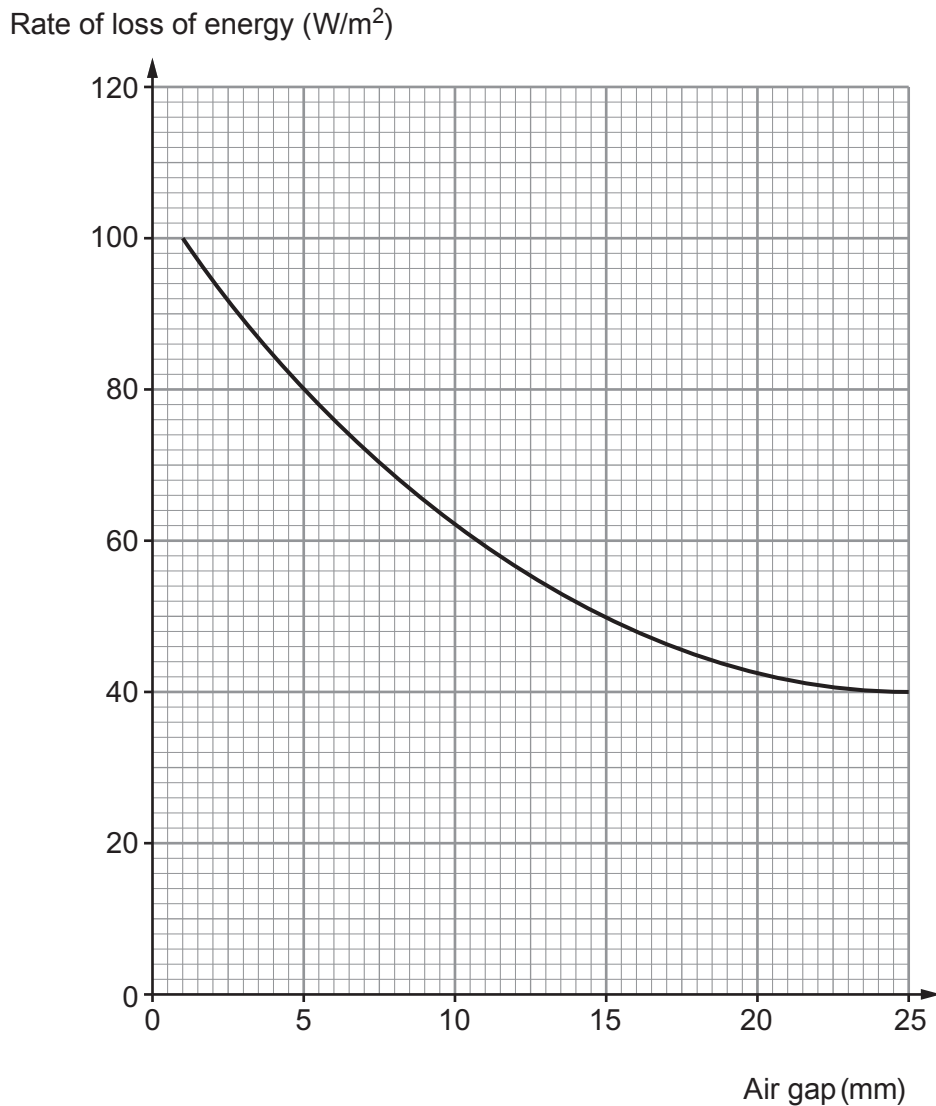

Cavity walls

Diagram 2 shows how a house wall is built. Its cavity is totally filled with foam.

Diagram 2

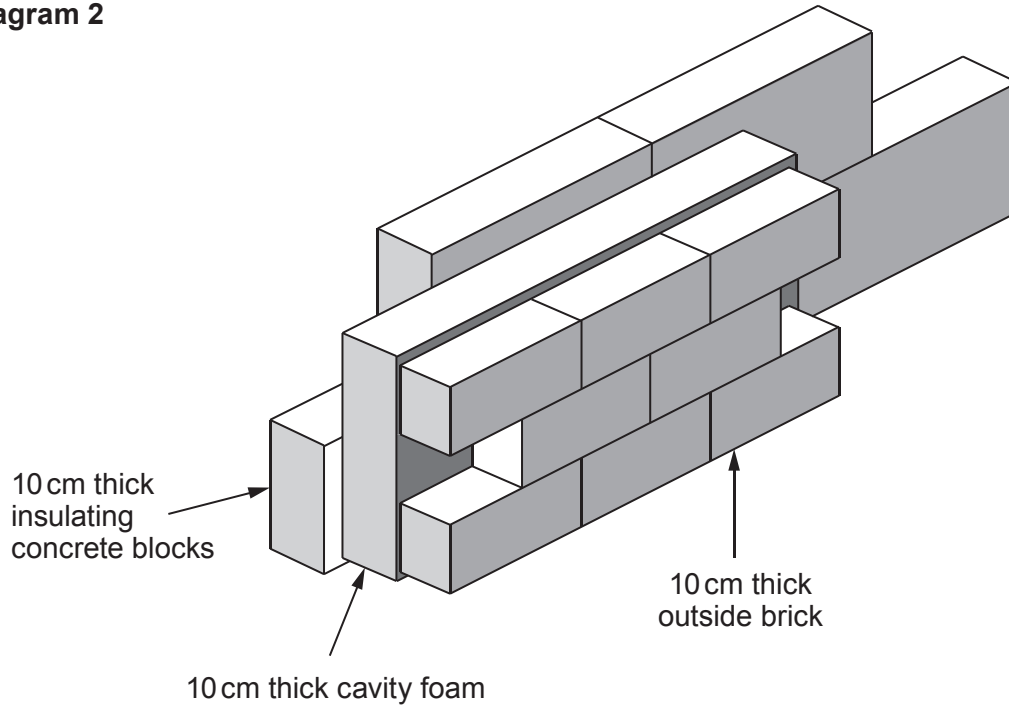

The insulating effectiveness of a material is given by a quantity called its R value.

R value is a measure of thermal resistance. The higher the R value of any material, the better its ability to resist the transmission of heat.

The R values for some common materials are shown in **Table 2** below. R values add together to give the total R value.

Table 2

Material	R value (Units)
A standard brick of thickness 10 cm	0.32
10 cm cavity wall insulating foam	3.60
10 cm thick insulating concrete block	2.08

Loft insulation

A **U value** tells us how much energy passes through a material per second.

It tells us the energy per second per square metre for a 1 °C temperature difference between the inside and the outside.

A U value of 1.61 means that 1.61 Joules of energy per second are transferred through 1 square metre of the material if the temperature difference between inside and outside is 1 °C.

U values are calculated using:

$$U = \frac{1}{R}$$

Modern regulations require that the heat loss through a roof should be limited so the U value is no more than 0.16 W/m²°C.

Table 3 shows how the U value varies with different thicknesses for two materials, **A** and **B**.

Table 3

Insulation Thickness	U value for A W/m ² °C	U value for B W/m ² °C
100 mm	0.30	0.20
120 mm	0.26	0.19
140 mm	0.23	0.17
160 mm	0.20	0.15
180 mm	0.18	0.14
200 mm	0.16	0.13

Making the most of our energy

The heat loss per second depends on the temperature difference between the inside and outside of the house.

To keep a house at a constant temperature, the energy losses must be balanced by energy produced by the heating system.

Electricity is convenient because it can be used in many ways including providing heating.

Power can be found using the equation:

$$\text{Power} = \frac{\text{energy}}{\text{time}}$$

The cost of electrical heating can be found using the equations:

$$\text{Units used} = \text{power (kW)} \times \text{time (h)}$$

$$\text{Total cost} = \text{cost of one unit} \times \text{units used}$$

BLANK PAGE