

**GENERAL CERTIFICATE OF SECONDARY EDUCATION
TWENTY FIRST CENTURY SCIENCE
ADDITIONAL SCIENCE A**

A218/01

Unit 4: Ideas in Context (Foundation Tier)

**Tuesday 7 June 2011
Afternoon**

Duration: 45 minutes

Candidates answer on the question paper.
A calculator may be used for this paper.

OCR supplied materials:

- Insert (inserted)

Other materials required:

- Pencil
- Ruler (cm/mm)

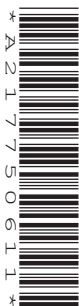

Candidate forename		Candidate surname	
-----------------------	--	----------------------	--

Centre number						Candidate number				
---------------	--	--	--	--	--	------------------	--	--	--	--

INSTRUCTIONS TO CANDIDATES

- The insert will be found in the centre of this document.
- Write your name, centre number and candidate number in the boxes above. Please write clearly and in capital letters.
- Use black ink. Pencil may be used for graphs and diagrams only.
- Read each question carefully. Make sure you know what you have to do before starting your answer.
- Write your answer to each question in the space provided. Additional paper may be used if necessary but you must clearly show your candidate number, centre number and question number(s).
- Answer **all** the questions.
- Do **not** write in the bar codes.

INFORMATION FOR CANDIDATES

- The number of marks is given in brackets [] at the end of each question or part question.
- The total number of marks for this paper is **40**.
- A list of physics equations is printed on page two.
- The Periodic Table is printed on the back page.
-  Where you see this icon you will be awarded marks for the quality of written communication in your answer.
- This document consists of **12** pages. Any blank pages are indicated.

TWENTY FIRST CENTURY SCIENCE EQUATIONS

Useful Relationships

Explaining Motion

$$\text{speed} = \frac{\text{distance travelled}}{\text{time taken}}$$

$$\text{momentum} = \text{mass} \times \text{velocity}$$

$$\text{change of momentum} = \text{resultant force} \times \text{time for which it acts}$$

$$\text{work done by a force} = \text{force} \times \text{distance moved in the direction of the force}$$

$$\text{change in energy} = \text{work done}$$

$$\text{change in GPE} = \text{weight} \times \text{vertical height difference}$$

$$\text{kinetic energy} = \frac{1}{2} \times \text{mass} \times [\text{velocity}]^2$$

Electric Circuits

$$\text{resistance} = \frac{\text{voltage}}{\text{current}}$$

$$\frac{\text{voltage across primary coil}}{\text{voltage across secondary coil}} = \frac{\text{number of turns in primary coil}}{\text{number of turns in secondary coil}}$$

$$\text{energy transferred} = \text{power} \times \text{time}$$

$$\text{power} = \text{potential difference} \times \text{current}$$

$$\text{efficiency} = \frac{\text{energy usefully transferred}}{\text{total energy supplied}} \times 100\%$$

The Wave Model of Radiation

$$\text{wave speed} = \text{frequency} \times \text{wavelength}$$

BLANK PAGE

Question 1 starts on page 4

PLEASE DO NOT WRITE ON THIS PAGE

Answer **all** the questions.

1 This question is based on the article ‘Rocket science’.

(a) Use the graphs in the article to answer the following questions.

(i) How high does the rocket go?

answer = m **[1]**

(ii) At what time is the thrust biggest?

answer = seconds **[1]**

(b) These diagrams show thrust and weight forces acting on the rocket.

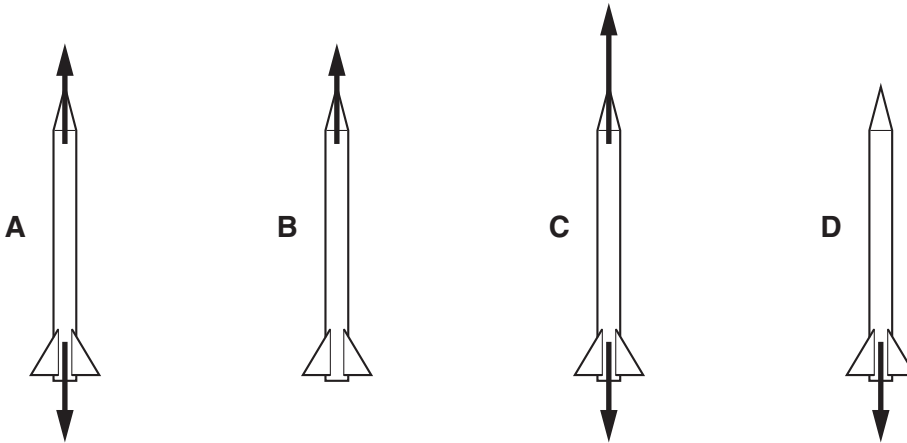

Which diagram, **A**, **B**, **C** or **D**, shows the forces on the rocket ...

... before the rocket engine starts?

answer

... when the rocket is increasing its speed going up?

answer

[2]

(c) The thrust from the rocket engine is the driving force.

Which **two** forces together act as the counter force, as the rocket goes up?

..... and **[1]**

(d) When the rocket engine is firing, the average upwards force on the rocket is 1800 N.

The rocket engine works for 7 seconds.

What is the change in momentum of the rocket during this time?

You must show your working.

change in momentum = Ns [2]

(e) After reaching its highest point the rocket falls back to the ground.

Complete the sentences about the energy changes as the rocket falls to the ground.

Use words from the list.

chemical force gravitational potential kinetic

As the rocket falls back to the ground, its energy increases.

As the rocket falls back to the ground, its energy decreases.

[2]

(f) (i) Explain how the rocket engine makes the rocket move.

Your answer should include

- the role of the exhaust gases
- the sizes and directions of the forces involved.

.....
.....
.....
.....
..... [3]

(ii) The rocket flies straight up.

At its highest point the rocket stops rising. It then falls.

What is the momentum of the rocket at its highest point?

momentum = kgm/s [1]

[Total: 13]

Turn over

2 This question is based on the article 'Brain power – the frontier of medical research into ageing'.

(a) The **cerebral cortex** is part of the human brain.

(i) Look at the article.

State **two** things that the cerebral cortex is involved in.

1

2 [1]

(ii) The cerebral cortex contains nerve cells called neurons.

What is the name of the **gap** between two neurons?

answer [1]

(b) (i) Which of the following are part of a neuron (nerve cell)?

Put a **ring** around the **two** correct answers.

cytoplasm

effector

gland

membrane [1]

(ii) Name **two** types of neuron.

answer and [1]

(iii) Complete the sentences about neurons.

Use correct words from the list.

chemical

electrical

impulses

light

resting

stimulated

turned off

Neurons transmit when they are

These are signals. [3]

(c) The **central nervous system** has two main parts.

One part is the brain.

What is the name of the other part?

..... [1]

(d) Professor Yankner studied the brains of thirty people.

The people were aged between 26 and 106 years.

Two people were over 100 years old.

What **percentage** of the group of people was over 100 years old?

Show your working.

answer = % [2]

(e) People do not remember all of their experiences.

Use the **information processing model**, including the diagram, to suggest why.



One mark is awarded for writing in sentences with correct spelling, punctuation and grammar.

.....
.....
.....
.....
..... [2+1]

(f) What may happen to **neuron pathways** in the brain when people become older?

.....
..... [1]

[Total: 14]

3 This question is based on the article ‘Copper – not just in mobile phones’.

- (a) The article mentions several metals that are used to make mobile phones.

Some of the metals are extracted from their compounds by heating with carbon and some are extracted by electrolysis.

Complete the table to show which method is used for each metal.

Use these metals.

aluminium iron lithium zinc

extracted by heating with carbon	extracted using electrolysis

[2]

- (b) From the article, give **one example** of an environmental problem caused by mining copper ore.

Give one method used by the mining industry to solve **this** problem.

environmental problem

.....

method to solve this problem

.....

[2]

- (c) Copper mines produce large amounts of waste rock.

The amount of waste rock is much larger than the amount of copper produced.

Explain why.

..... [1]

- (d) The ‘electrolysis’ process produces sulfuric acid.

Suggest how this sulfuric acid could be recycled in the process.

..... [1]

(e) Both the 'blister' process and the 'electrolysis' process use large amounts of energy.

Each process uses the energy in different ways.

Use information from the flow diagrams to say how the energy is used in each process.

.....

.....

..... [2]

(f) The diagram shows the electrolysis of dilute copper sulfate solution.

Complete the labels on the diagram.

Use words from the list.

- electron electrolyte indicator negative neutral positive**

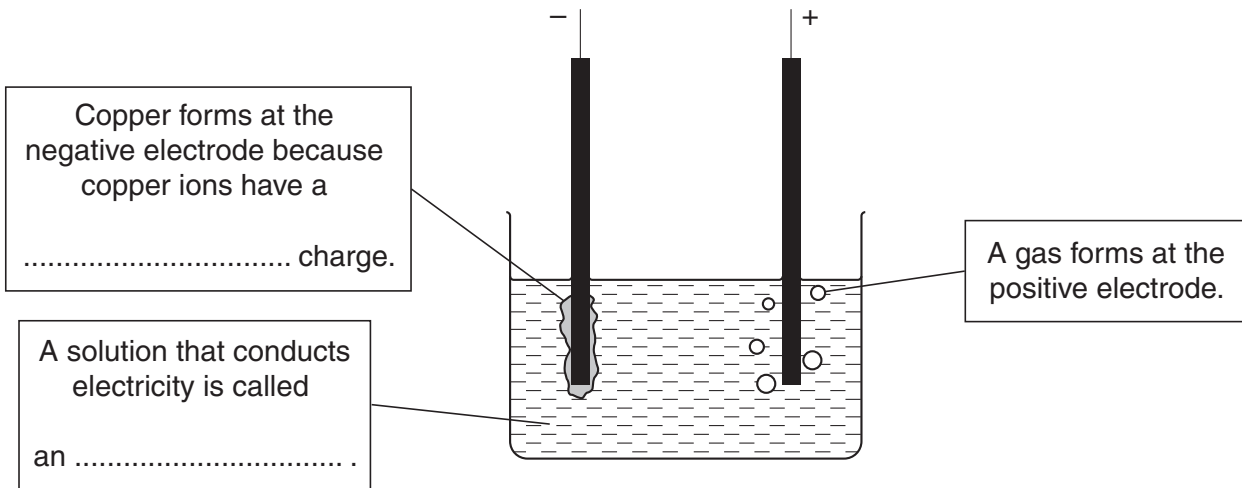

[2]

(g) The table in the article shows some properties of copper.

Copper is easily bent into shape when making jewellery.

Which property in the table shows this?

Put a ring around the correct answer.

electrical conductivity malleability melting point thermal conductivity [1]

(h) It is important that we recycle as much copper as possible rather than extract it from fresh ores.

Use information from the article to explain why.

.....
.....
.....
..... [2]

[Total: 13]

END OF QUESTION PAPER

PLEASE DO NOT WRITE ON THIS PAGE



Copyright Information

OCR is committed to seeking permission to reproduce all third-party content that it uses in its assessment materials. OCR has attempted to identify and contact all copyright holders whose work is used in this paper. To avoid the issue of disclosure of answer-related information to candidates, all copyright acknowledgements are reproduced in the OCR Copyright Acknowledgements Booklet. This is produced for each series of examinations and is freely available to download from our public website (www.ocr.org.uk) after the live examination series.

If OCR has unwittingly failed to correctly acknowledge or clear any third-party content in this assessment material, OCR will be happy to correct its mistake at the earliest possible opportunity.

For queries or further information please contact the Copyright Team, First Floor, 9 Hills Road, Cambridge CB2 1GE.

OCR is part of the Cambridge Assessment Group; Cambridge Assessment is the brand name of University of Cambridge Local Examinations Syndicate (UCLES), which is itself a department of the University of Cambridge.

The Periodic Table of the Elements

1	2	3	4	5	6	7	0	
7 Li lithium 3	9 Be beryllium 4	11 Na sodium 11	12 C carbon 6	13 Al aluminium 13	14 N nitrogen 7	15 O oxygen 8	16 F fluorine 9	17 Ne neon 10
19 K potassium 19	20 Ca calcium 20	23 Sc scandium 21	24 Ti titanium 22	25 V vanadium 23	26 Cr chromium 24	27 Mn manganese 25	28 Fe iron 26	29 Co cobalt 27
37 Rb rubidium 37	38 Sr strontium 38	39 Y yttrium 39	40 Zr zirconium 40	41 Nb niobium 41	42 Mo molybdenum 42	43 Tc technetium [98]	44 Ru ruthenium 44	45 Rh rhodium 45
55 Cs caesium 55	56 Ba barium 56	57 La* lanthanum 57	72 Hf hafnium 72	73 Ta tantalum 73	74 W tungsten 74	75 Re rhenium 75	76 Os osmium 76	77 Ir iridium 77
87 Fr francium 87	88 Ra radium 88	89 Ac* actinium 89	104 Rf rutherfordium 104	105 Db dubnium 105	106 Sg seaborgium 106	107 Bh bohrium 107	108 Hs hassium 108	109 Mt meitnerium 109
133 Cs caesium 55	137 Ba barium 56	139 La* lanthanum 57	178 Hf hafnium 72	181 Ta tantalum 73	184 W tungsten 74	186 Re rhenium 75	190 Os osmium 76	192 Ir iridium 77
223 Fr francium 87	226 Ra radium 88	227 Ac* actinium 89	261 Rf rutherfordium 104	262 Db dubnium 105	266 Sg seaborgium 106	268 Mt meitnerium 109	277 Hs hassium 108	272 Rg roentgenium 111
119 Ac actinium 89	120 Th thorium 90	121 Pa protactinium 91	122 U uranium 92	123 Np neptunium 93	124 Pu plutonium 94	125 Am americium 95	126 Cm curium 96	127 Bk berkelium 97
157 Fr francium 87	158 Ra radium 88	159 Ac* actinium 89	207 Pb lead 82	208 Bi bismuth 83	209 Po polonium 84	210 At astatine 85	211 Rn radon 86	212 Fr francium 87
287 Uu unbinilium 112	288 Uub unbinilium 113	289 Uu unbinilium 114	290 Uu unbinilium 115	291 Uu unbinilium 116	292 Uu unbinilium 117	293 Uu unbinilium 118	294 Uu unbinilium 119	295 Uu unbinilium 120
Elements with atomic numbers 112-116 have been reported but not fully authenticated								

1 H hydrogen 1

relative atomic mass atomic symbol name atomic (proton) number

* The lanthanoids (atomic numbers 58-71) and the actinoids (atomic numbers 90-103) have been omitted.

The relative atomic masses of copper and chlorine have not been rounded to the nearest whole number.