

GENERAL CERTIFICATE OF SECONDARY EDUCATION
GATEWAY SCIENCE
SCIENCE B

UNIT 1: Modules B1 C1 P1 (Higher Tier)

TUESDAY 15 JANUARY 2008

Afternoon
Time: 1 hour

Candidates answer on the question paper.

Additional materials (enclosed):
None

Calculators may be used.

Additional materials: Pencil
Ruler (cm/mm)



Candidate
Forename

Candidate
Surname

Centre
Number

--	--	--	--	--

Candidate
Number

--	--	--	--

INSTRUCTIONS TO CANDIDATES

- Write your name in capital letters, your Centre Number and Candidate Number in the boxes above.
- Use blue or black ink. Pencil may be used for graphs and diagrams only.
- Read each question carefully and make sure that you know what you have to do before starting your answer.
- Answer **all** the questions.
- Do **not** write in the bar codes.
- Do **not** write outside the box bordering each page.
- Write your answer to each question in the space provided.

INFORMATION FOR CANDIDATES

- The number of marks for each question is given in brackets [] at the end of each question or part question.
- The total number of marks for this paper is **60**.
- A list of physics equations is printed on page two.
- The Periodic Table is printed on the back page.

FOR EXAMINER'S USE

Section	Max	Mark
A	20	
B	20	
C	20	
TOTAL	60	

This document consists of **23** printed pages and **1** blank page.

EQUATIONS

$$\text{efficiency} = \frac{\text{useful energy output}}{\text{total energy input}}$$

$$\text{energy} = \text{mass} \times \text{specific heat capacity} \times \text{temperature change}$$

$$\text{energy} = \text{mass} \times \text{specific latent heat}$$

$$\text{fuel energy input} = \text{waste energy output} + \text{electrical energy output}$$

$$\text{power} = \text{voltage} \times \text{current}$$

$$\text{energy supplied} = \text{power} \times \text{time}$$

$$\text{energy (kilowatt hours)} = \text{power (kW)} \times \text{time (h)}$$

$$\text{wave speed} = \text{frequency} \times \text{wavelength}$$

Answer **all** the questions.

Section A – Module B1

1 Claudia had a motor-cycle accident and had to have one of her arms removed.

This arm has been replaced by an artificial arm.

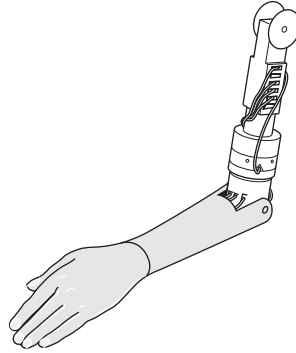

Scientists have managed to reconnect Claudia’s nerves to the artificial arm.

Claudia can now control the movement of her artificial arm by thinking about it.

(a) The nerves in Claudia’s healthy arm contain different types of nerve cells (neurones).

Look at the list of neurones.

- motor neurone**
- relay neurone**
- sensory neurone**

Put a **ring** around the type of neurone that takes signals to Claudia’s muscles. [1]

(b) Claudia touches a hot object with her artificial arm.

She does **not** automatically move her arm away.

Suggest why.

.....

..... [1]

[Total: 2]

2 This article appeared in a recent newspaper.

Did some mammoths have blond hair?

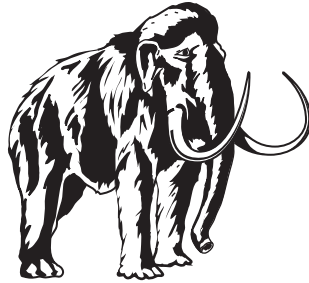

Scientists have managed to extract DNA from the cells of a mammoth that has been dead for 43 000 years.

They have discovered a gene that codes for a protein.

This protein affects hair colour in humans and other animals.

The mammoth had two versions of the gene.

One was dominant and would make the hair dark. The other was recessive and would make the hair blond coloured.

(a) Write down words from the passage that mean the same as the following sentences.

(i) The name given to a region of code on a chromosome. [1]

(ii) A chemical that is made up of amino acids. [1]

(b) Using your biological knowledge, finish the following sentences about the mammoth.

The dominant and recessive versions of the gene are called

A mammoth with a dominant and a recessive version of the gene is said to be

..... for this gene.

This means that its hair colour would have been [3]

[Total: 5]

3 Contraceptive pills can be taken by women to prevent pregnancy.

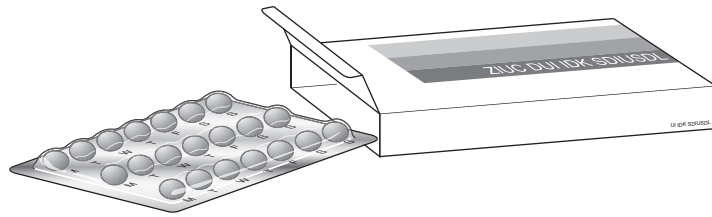

(a) Write down the name of **one** hormone that is usually in female contraceptive pills.

..... [1]

(b) A new method of contraception is being produced by scientists.

It is given to men and stops the production of sperm.

The men are given an injection.

This makes the man's body produce antibodies.

The antibodies attack proteins needed for sperm production.

Why will these antibodies attack only proteins that are needed for sperm production?

..... [1]

(c) New treatments can be tested on animals before they are given to humans.

(i) Suggest why new treatments are sometimes tested on animals.

.....
..... [1]

(ii) Write down **one** other way that treatments can be tested before human use **without** using live animals.

.....
..... [1]

[Total: 4]

4 This newspaper article gives some information about a new drug.

A New Drug – The Fat Controller?

A new drug has just been developed that might help people lose weight.

Experts say that about 10 million people in Britain are obese. This means they have a Body Mass Index (BMI) of over 30.

The drug works by stopping neurotransmitters passing messages between neurones in the brain. This stops people feeling hungry.

Scientists also believe that the drug can help people give up smoking and help people with diabetes.

(a) The scientists think that the drug works because its molecules are similar in shape to the neurotransmitter molecule.

Suggest why this stops the passing of messages.

.....
.....
..... [2]

(b) The new drug may help people to give up smoking.

Why is it so hard for people to give up smoking?

.....
..... [1]

(c) Barry thinks he might be obese.

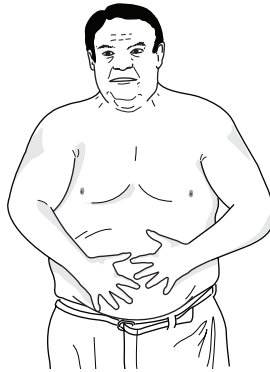

Barry's body mass is 100 kg and his height is 1.7 metres.

Use this formula to work out if Barry is obese.

$BMI = \text{mass in kg} / (\text{height in m})^2$

BMI =

Is Barry obese?

explanation [2]

[Total: 5]

5 The graph shows some information about how survival rates for different cancers have changed from 1975 to 1997.

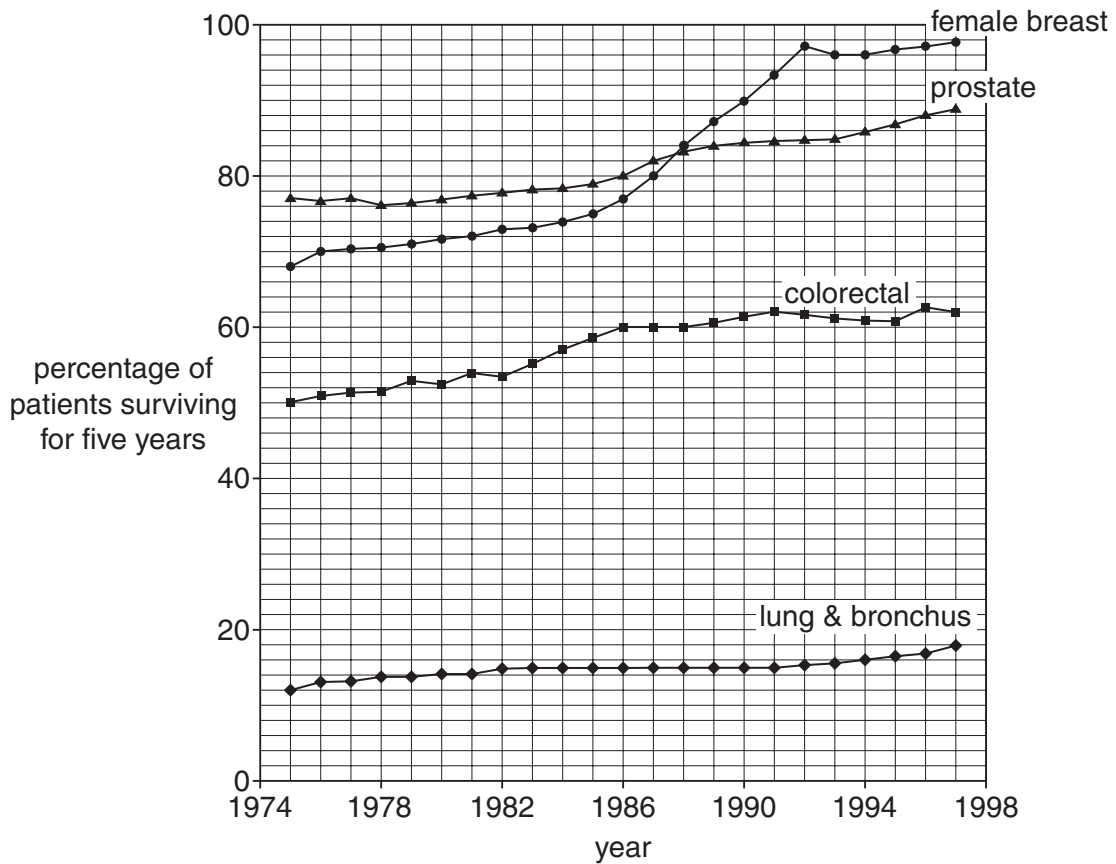

(a) A doctor used the graph to give some information about cancer treatment.

Finish the sentences in the box.



The type of cancer that had the highest survival rate in 1980 was

The greatest improvement in survival rates over the 22 year period is in cancer.

[2]

(b) Tumours in the lungs can be either malignant or benign.

How do malignant tumours differ from benign tumours?

.....

..... [2]

[Total: 4]

Section B – Module C1

6 Crude oil is a fossil fuel.

Crude oil is separated at an oil refinery into useful fractions.

This is done by fractional distillation.

Look at the diagram. It shows a fractionating column.

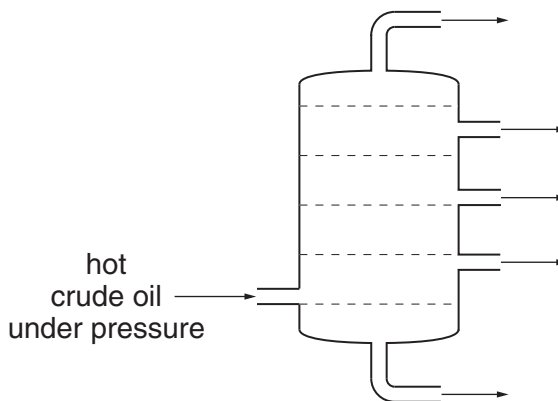

(a) Place an **X** on the diagram to show the **hottest** part of the fractionating column. [1]

(b) Complete the sentences to explain how fractional distillation works.

Choose from the list.

flammability

boiling temperature

reactivity

stronger

the same as

weaker

The forces between molecules are called intermolecular forces. During boiling, these forces become weaker.

Intermolecular forces between large hydrocarbon molecules are

..... than those between small hydrocarbon molecules.

Hydrocarbons with large molecules have a higher

than those of small molecules.

[2]

(c) Some fractions from crude oil are cracked.

Cracking changes large alkane molecules into smaller alkane and alkene molecules.

Why is cracking used?

.....

..... [1]

[Total: 4]

7 This question is about cooking and foods.

Look at the pictures of some foods.

apple

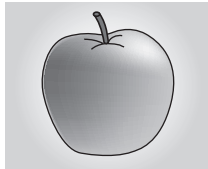

bread

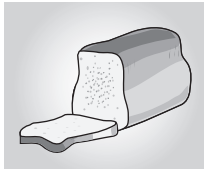

carrot



chicken



butter



fish



(a) Write down the name of **one** food that contains a lot of carbohydrate.

Choose from the foods in the pictures.

..... [1]

(b) Write down the name of **one** food that contains a lot of protein.

Choose from the foods in the pictures.

..... [1]

(c) Write about why we often cook fish before eating it.

.....
.....
.....
..... [2]

[Total: 4]

8 This question is about compounds that contain carbon.

Look at the displayed formulae.

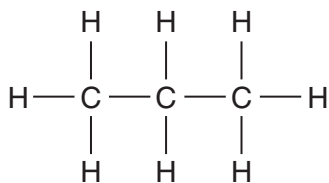

compound **A**

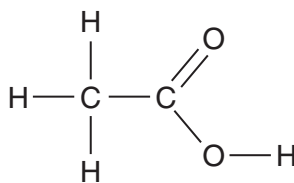

compound **B**



compound **C**

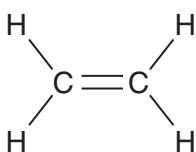

compound **D**

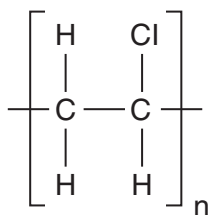

compound **E**

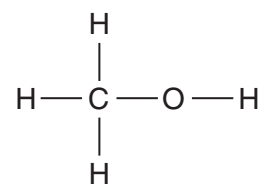

compound **F**

(a) Which compound is an **alkene**?

Choose from **A, B, C, D, E** or **F**.

..... [1]

(b) Which compound is a **polymer**?

Choose from **A, B, C, D, E** or **F**.

..... [1]

(c) Which compound is an **alkane**?

Choose from **A, B, C, D, E** or **F**.

..... [1]

(d) The molecular formula for compound **D** is C_2H_4 .

Write down the molecular formula for compound **A**.

..... [1]

[Total: 4]

9 Callum is using a Bunsen burner.

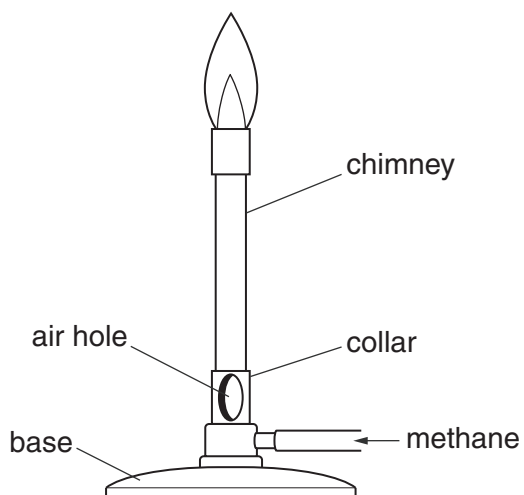

He has the air hole open.

There is a blue flame.

In the flame the methane reacts with oxygen as shown in this word equation.

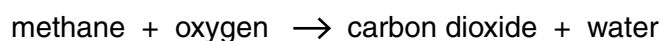

(a) During complete combustion, methane, CH_4 , reacts with oxygen, O_2 .

Carbon dioxide and water are made.

Write a balanced **symbol** equation for this reaction.

..... [2]

(b) Callum closes the air hole of the Bunsen burner.

Incomplete combustion happens.

The flame changes colour from blue to yellow.

One disadvantage of incomplete combustion is that less heat is released.

Write about **other** disadvantages of incomplete combustion.

.....

 [2]

(c) Ethene can be used as a fuel.

Look at the diagram. It shows the displayed formula of ethene.

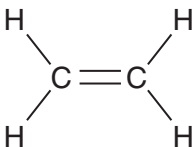

ethene

Ethene is an unsaturated hydrocarbon.

Explain why ethene is unsaturated.

..... [1]

[Total: 5]

10 David and Ryan investigate three fuels.

They want to find out which fuel gives off most energy.

They burn each fuel separately.

Look at the diagram. It shows the apparatus they use.

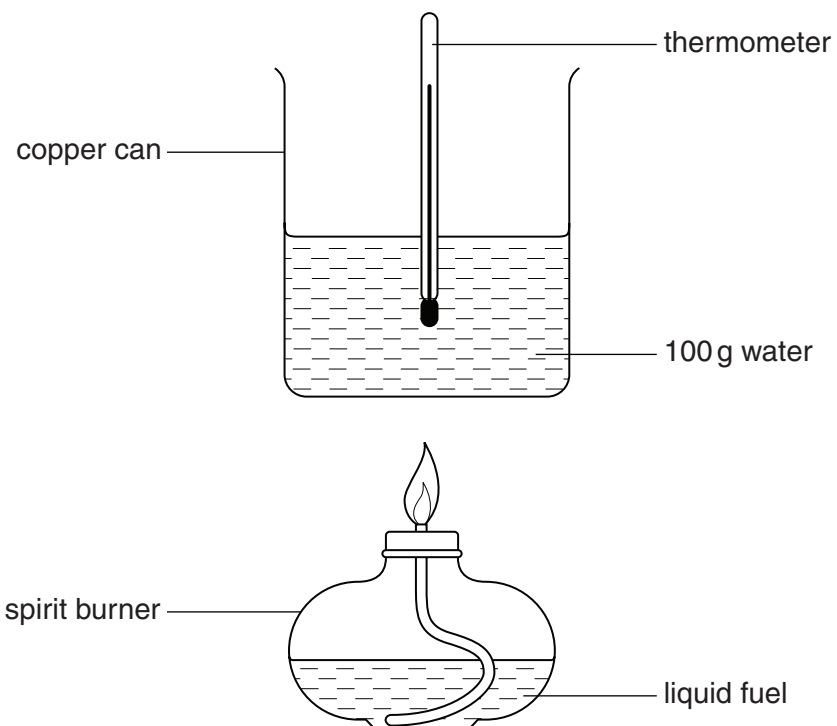

Look at the table.

It shows the results for burning 2 g of ethanol and heating 100 g of water.

fuel	temperature at start in °C	temperature at end in °C
ethanol	18	48

Calculate the amount of heat transferred. (Specific heat capacity of water is $4.2 \text{ J/g } ^\circ\text{C}$)

.....

.....

.....

answer J

[3]

[Total: 3]

15
BLANK PAGE

Question 11 starts on page 16
PLEASE DO NOT WRITE ON THIS PAGE

Section C – Module P1

11 This question is about heat energy.

Rajvir wants to investigate how things heat up.

He uses three metal blocks.

They all start at the **same temperature**.

Block **A** and block **B** have a mass of 1 kg. Block **C** has a mass of 2 kg.

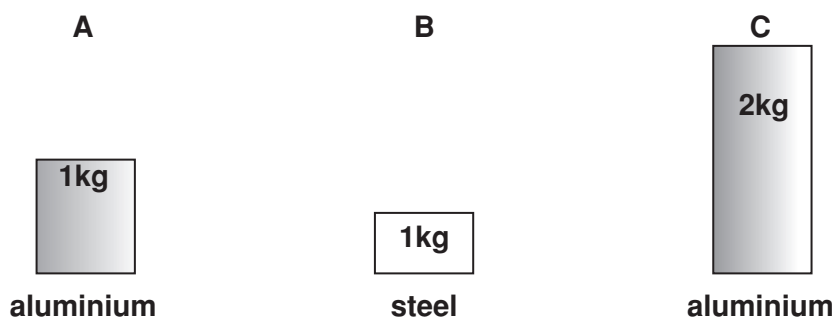

Rajvir heats the blocks for 5 minutes.

He uses **identical** heaters.

He measures the **final** temperature of each block.

Look at his table.

block	final temperature in °C	temperature rise in °C
A	60	40
B	100	80
C	40	20

He finds out that block **A** and block **B** have different **specific heat capacities**.

Block **A** has a specific heat capacity of **900 J/kg °C**.

(a) Complete the following sentence about specific heat capacity.

Specific heat capacity is the needed to raise the temperature of

1 kg of a material by

[2]

(b) Rajvir looks at his results.

He decides that the specific heat capacity of aluminium is approximately **twice** that of steel.

Explain why.

.....
..... [1]

(c) Rajvir leaves the blocks for ten minutes.

The blocks cool down. They have lost heat by **conduction**, **convection** and **radiation**.

Rajvir's house loses heat in a similar way.

He reduces the heat loss through the **walls** of his house.

Complete the following sentences.

Choose from the list.

- air
- conduction
- convection
- foam
- radiation
- water

Heat is lost through the brick walls of the house by

The **gap** between the inner and outer brick walls (the **cavity**) can be filled with

..... This reduces the heat loss across the gap by

..... and [2]

[Total: 5]

12 This question is about heat transfer and efficiency.

Tori has a radiator in her room.

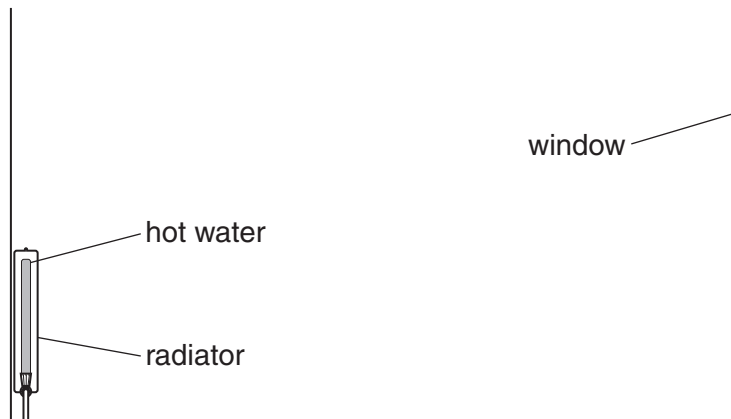

The radiator is made of metal.

It has hot water inside it.

(a) Tori thinks that a lot of energy from the radiator is **wasted**.

She thinks the radiator has a low **efficiency**.

She finds this diagram in a book.

It shows how much energy is lost from a radiator.

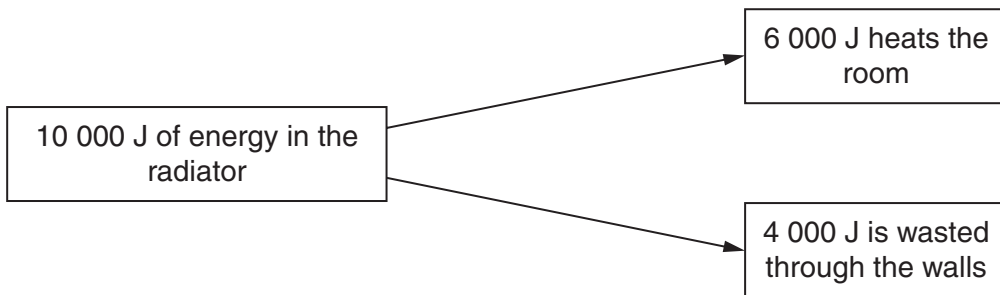

Calculate the efficiency of the radiator in heating the room.

The list of equations on page 2 may help you.

.....

.....

.....

.....

efficiency = %

[2]

(b) To reduce energy costs Tori changes the window to a **double glazed** one.

Explain how this reduces the amount of heat lost from her room.

In your answer, use ideas about particles.

.....

.....

..... [2]

[Total: 4]

13 This question is about ultraviolet radiation from the Sun.

Megan knows that ultraviolet radiation can harm people.

Megan wants to go outside on a sunny day.

She looks at these two sun creams.



SPF means **Sun Protection Factor**.

(a) (i) Megan uses Golden Glow sun cream.

How long can Megan safely stay in the Sun?

Complete the table below.

safe time in the Sun for Megan	
without sun cream	with Golden Glow sun cream, SPF 15
5 minutes	

[1]

(ii) She decides that Bronze Blush will be better for her in the Sun.

Suggest why.

In your answer write about

- exposure times
- risk.

.....

.....

.....

..... [3]

(b) Megan has light coloured skin.

Her skin burns easily when she is out in the Sun.

Suggest why.

.....
..... [1]

(c) Part of the Earth’s atmosphere protects us from ultraviolet radiation.

Some scientists are worried that the layer is being damaged.

Why are they worried?

In your answer you should

- name the protective layer
- describe how it provides protection
- say how the layer is being damaged.

.....
.....
.....
..... [2]

[Total: 7]

14 This question is about microwave cooking.

Look at the diagram of a microwave cooker.

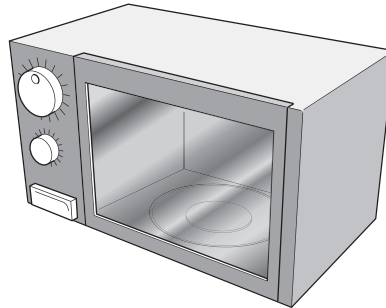

(a) Microwaves cook the food by transferring energy to it.

Complete the following sentences to explain how.

Microwaves are absorbed in the layers of the food.

The energy is absorbed by the fat and molecules in these layers.

This increases the energy of the molecules.

The energy is transferred to the centre of the food by and

.....

[3]

(b) The food would cook more quickly if microwaves with higher energy could be used.

What feature of the **waves** would have to be changed to make them carry more energy?

..... [1]

[Total: 4]

END OF QUESTION PAPER

PLEASE DO NOT WRITE ON THIS PAGE

Permission to reproduce items where third-party owned material protected by copyright is included has been sought and cleared where possible. Every reasonable effort has been made by the publisher (OCR) to trace copyright holders, but if any items requiring clearance have unwittingly been included, the publisher will be pleased to make amends at the earliest possible opportunity.

OCR is part of the Cambridge Assessment Group. Cambridge Assessment is the brand name of University of Cambridge Local Examinations Syndicate (UCLES), which is itself a department of the University of Cambridge.

The Periodic Table of the Elements

1	2	3	4	5	6	7	0										
7 Li lithium 3	9 Be beryllium 4	11 Na sodium 11	12 C carbon 6	13 Al aluminium 13	14 N nitrogen 7	15 P phosphorus 15	16 O oxygen 8	17 F fluorine 9	18 Ne neon 10								
19 K potassium 19	20 Ca calcium 20	23 Sc scandium 21	24 Ti titanium 22	25 V vanadium 23	26 Cr chromium 24	27 Mn manganese 25	28 Fe iron 26	29 Co cobalt 27	30 Ni nickel 28	31 Cu copper 29	32 Zn zinc 30	33 Ga gallium 31	34 Ge germanium 32	35 As arsenic 33	36 Se selenium 34	37 Br bromine 35	38 Kr krypton 36
37 Rb rubidium 37	38 Sr strontium 38	39 Y yttrium 39	40 Zr zirconium 40	41 Nb niobium 41	42 Mo molybdenum 42	43 Tc technetium [98]	44 Ru ruthenium 44	45 Rh rhodium 45	46 Pd palladium 46	47 Ag silver 47	48 Cd cadmium 48	49 In indium 49	50 Sn tin 50	51 Sb antimony 51	52 Te tellurium 52	53 I iodine 53	54 Xe xenon 54
55 Cs caesium 55	56 Ba barium 56	57 La* lanthanum 57	72 Hf hafnium 72	73 Ta tantalum 73	74 W tungsten 74	75 Re rhenium 75	76 Os osmium 76	77 Ir iridium 77	78 Pt platinum 78	79 Au gold 79	80 Hg mercury 80	81 Tl thallium 81	82 Pb lead 82	83 Bi bismuth 83	84 Po polonium [209]	85 At astatine [210]	86 Rn radon [222]
87 Fr francium 87	88 Ra radium 88	89 Ac* actinium 89	104 Rf rutherfordium [261]	105 Db dubnium [262]	106 Sg seaborgium [266]	107 Bh bohrium [264]	108 Hs hassium [277]	109 Mt meitnerium [268]	110 Ds darmstadtium [271]	111 Rg roentgenium [272]	Elements with atomic numbers 112-116 have been reported but not fully authenticated						

1 H hydrogen 1

relative atomic mass
atomic symbol
name
atomic (proton) number

* The lanthanoids (atomic numbers 58-71) and the actinoids (atomic numbers 90-103) have been omitted.

The relative atomic masses of copper and chlorine have not been rounded to the nearest whole number.