

**GENERAL CERTIFICATE OF SECONDARY EDUCATION
 TWENTY FIRST CENTURY SCIENCE
 SCIENCE A**

Unit 3 Modules B3 C3 P3 (Foundation Tier)

**SAMPLE ASSESSMENT MATERIAL
 (from 2010 onwards)**

Time: 40 minutes

Candidates answer on the question paper

Additional materials (enclosed):

None

Calculators may be used.

Additional materials: Pencil
 Ruler (cm/mm)

Candidate
 Forename

Candidate
 Surname

Centre
 Number

--	--	--	--	--

Candidate
 Number

--	--	--	--

INSTRUCTIONS TO CANDIDATES

- Write your name in capital letters, your Centre Number and Candidate Number in the boxes above.
- Use black ink. Pencil may be used for graphs and diagrams only.
- Read each question carefully and make sure you know what you have to do before starting your answer.
- Answer **all** the questions.
- Do **not** write in the bar codes.
- Do **not** write outside the box bordering each page.
- Write your answer to each question in the space provided.

INFORMATION FOR CANDIDATES

- The number of marks for each question is given in brackets [] at the end of each question or part question.
- The total number of marks for this paper is **42**.

FOR EXAMINER'S USE		
Qu.	Max.	Mark
1	7	
2	4	
3	3	
4	7	
5	8	
6	10	
7	3	
TOTAL	42	

This document consists of **16** printed pages.

Answer **all** questions.

1 The diagram shows an octopus eye.

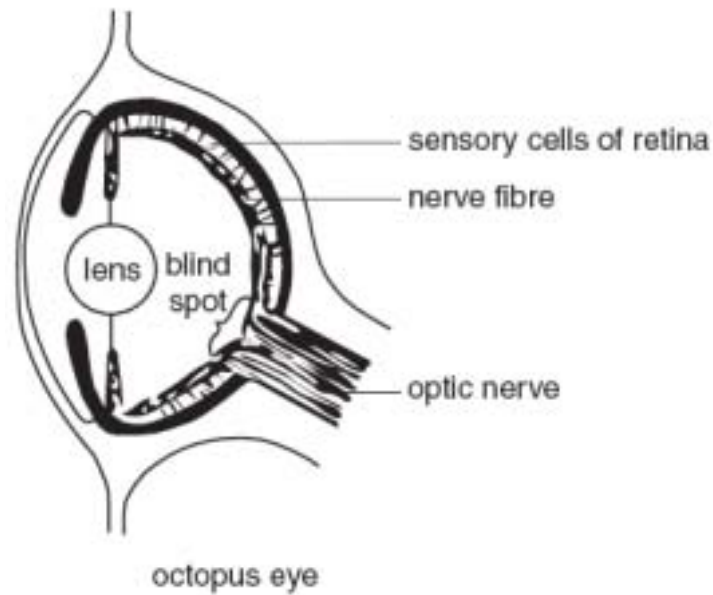

(a) Eyes help animals survive by detecting changes.

Complete the sentences. Choose words from this list.

effector

hormonal

nervous

receptor

responses

stimuli

Cells which detect changes are called cells.

The changes detected by these cells are called

Eyes are part of the system.

[3]

(b) Octopus eyes are very complex.

Some people say they have been designed.

Most scientists believe that eyes evolved by natural selection.

Explain how natural selection may have led to eyes that could focus light better.

Use these ideas to help you

- variation in eyes
- survival
- reproduction

.....

.....

.....

.....

.....

.....

.....

.....

[4]
[Total: 7]

2 Read the article about fish and fishing.

What's healthy and what's sustainable?

Sales of oily fish have increased following reports that omega-3 oils in the fish can make you live longer.
 Scientists warn that current levels of fishing are not sustainable.
 Scientists also say poisons have built up in fish because of pollution.
 Fishing nets can damage plants which are the **basis for local ecosystems**.

The table shows some information about five species of fish.

fish	contains omega-3 oil	sustainable	contaminated with poisons
cod	no	no	no
eel	no	no	yes
whiting	no	no	yes
herring	yes	yes	no
mackerel	yes	yes	yes

(a) Which fish would you recommend as being the safest **and** healthiest to eat?

answer [1]

(b) Four friends are arguing about what sustainable fishing means.



Who has understood what **sustainable** means?

answer [1]

(c) Look at the food web of some organisms that live in the North Atlantic.

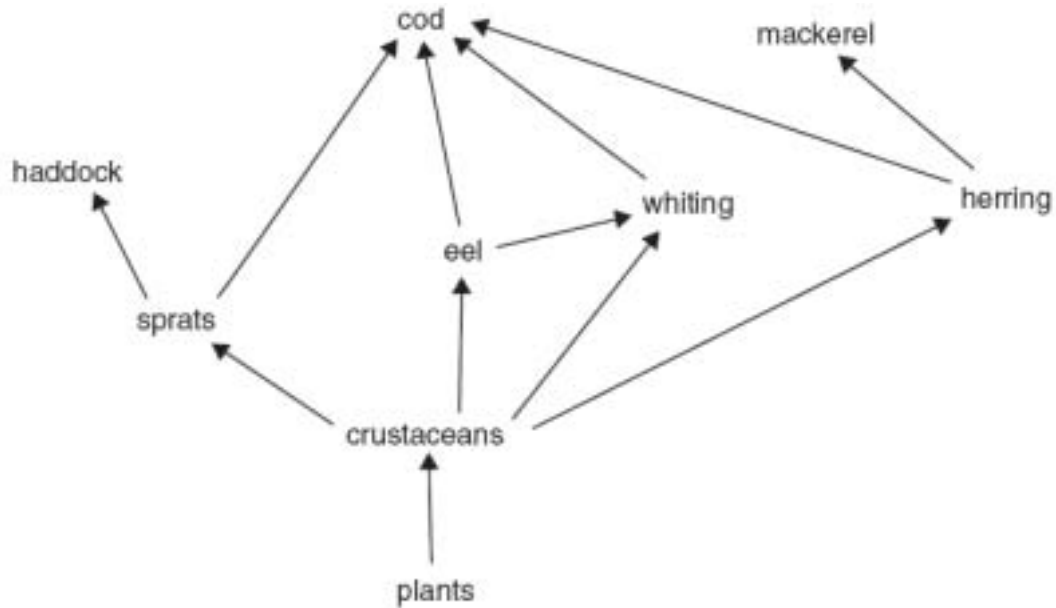

(i) In the article, plants are described as the 'basis for local ecosystems'.

Put a tick (✓) in the box next to the **best** explanation for this description.

All the animals eat plants.

Crustaceans eat all the plants.

Food chains always start with plants.

Only animals can make their own food.

[1]

(ii) Scientists think that there will be a **fall** in the number of herring.

How will this affect the number of mackerel?

Put a tick (✓) in the box next to the correct statement.

There will be fewer mackerel because there will be less food.

There will be the same number of mackerel because mackerel don't eat herring.

There will be more mackerel because they will not be eaten by herring.

[1]

[Total: 4]

- 3 The diagram below shows one possible pattern for human evolution. This is a simplified diagram which only shows four of the many hominid species which scientists think have existed over the last 1.7 million years.

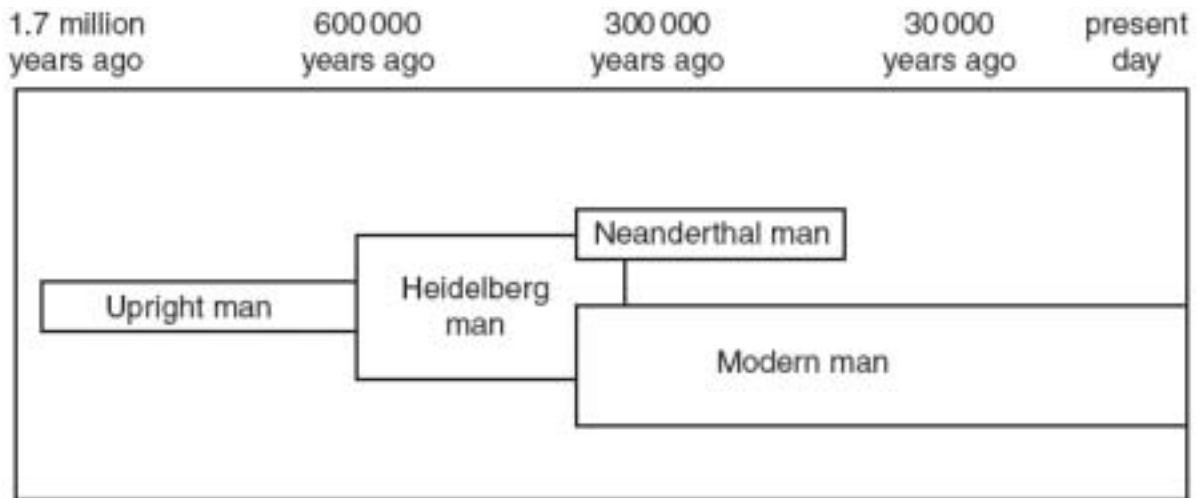

- (a) Some hominid species are extinct.

Put **one** tick (✓) in the table to show a species which is **extinct**.

Put **one** tick (✓) in the table to show a species which is **not extinct**.

hominid species	extinct	not extinct
Upright man		
Heidelberg man		
Neanderthal man		
Modern man		

[1]

- (b) Which species is likely to have had the smallest brain?

Put a tick (✓) in the box next to the best answer.

Upright man	<input type="checkbox"/>
Heidelberg man	<input type="checkbox"/>
Neanderthal man	<input type="checkbox"/>
Modern man	<input type="checkbox"/>

[1]

- (c) In 2004 on the Indonesian island of Flores, scientists found the skull and some bones from an adult female. Read the statements about this find.

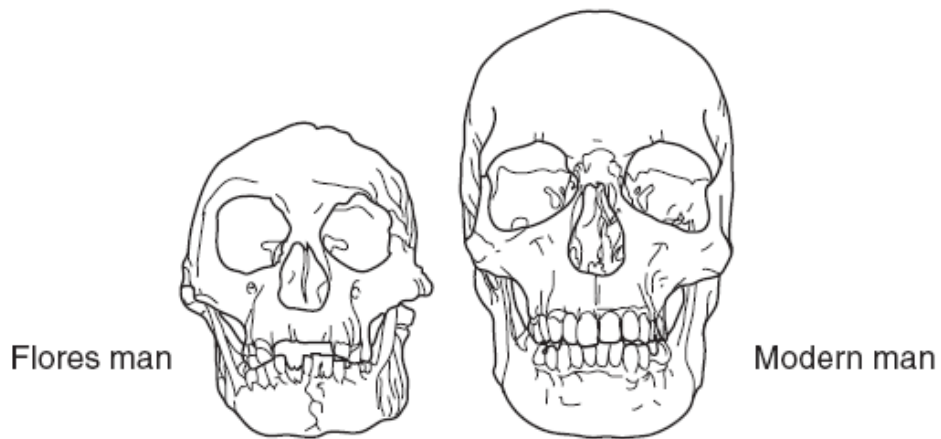

- A The female was only one metre tall.
- B Next to the bones, scientists also found stone tools and signs of cooking.
- C The bones were 13 000 years old.
- D Scientists said the bones belonged to a species new to science. They called this species Flores man.

Statement **B** is an example of data. Which other **two** statements, **A**, **C** or **D**, are also data?

answer and [1]

[Total: 3]

- 4 Eve is trying to eat healthily. She knows that it is important to cut down on some food chemicals such as sugar, fat and salt.

Eve has a fridge magnet that shows guidelines for healthy amounts of sugar, fat and salt in foods.

CHECK THE LABELS!



	What's a little? (per 100g)	What's a lot? (per 100g)
Sugar	2g	10g
Fat	3g	20g
Salt	0.3g	1.5g

- (a) Which food chemical, from the table, should be eaten in the smallest amount?

Put a ring around the correct answer.

sugar

fat

salt

[1]

- (b) Eve looks at the label on a packet of Krunchy Crisps.

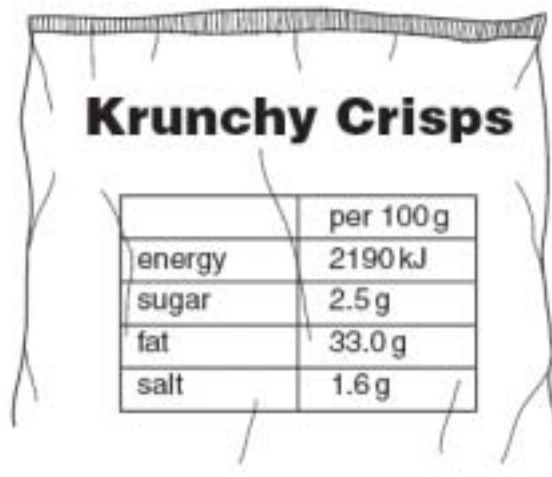

	per 100g
energy	2190 kJ
sugar	2.5 g
fat	33.0 g
salt	1.6 g

- (i) Use information from the fridge magnet and the Krunchy Crisps packet to decide whether the crisps are **high** or **low** in sugar, fat and salt.

Put a tick (✓) in each correct box.

	high	low
sugar		
fat		
salt		

[2]

- (ii) Eve knows that she cannot assess the risk of eating Krunchy Crisps using only this information.

Which statements show why she cannot assess the risk?

Put ticks (✓) in the **two** correct boxes.

She might be eating other foods that are more harmful than crisps.

She does not know the outcomes of eating too much sugar, salt and fat.

She needs to take into account the amount of crisps that she eats.

Other brands of crisps may have different amounts of sugar, salt and fat.

[2]

- (c) Eve reads an article that says that eating too much fat can increase the risk of getting heart disease.

Eve knows that her grandmother eats lots of fatty foods and has a very healthy heart.

Explain how this can happen, using the term **correlation** in your answer.

.....

.....

.....

.....

[2]

[Total: 7]

5 Joe is a farmer.

He wants to increase the yield of cereal crops from one of his fields.

(a) What effect does each of the following have on the crop yield?

Put a tick (✓) in each correct box.

	increases crop yield	decreases crop yield
adding nitrogen compounds to the soil		
fungal disease on the crops		
adding manure to the soil		

[1]

(b) Joe sees that there are a lot of greenfly on the crops in the field.

Greenfly are pests which suck up plant sap and spread disease.

Greenfly are eaten by many other types of insect.

He is deciding whether or not to spray the greenfly with pesticide.

Should he do this?

Give reasons for and against.

.....

.....

.....

..... [3]

- (c) Joe sells his cereals to a food company.

The following list shows some chemicals that can be found in cereals.

Some chemicals found in cereals are harmful and can cause allergies in some people.

Put a **ring** around each of the **two** harmful chemicals.

aflatoxin from mould

cellulose

fibre

herbicide

starch

[2]

- (d) Cereals are important foods because they contain carbohydrates and proteins.

Draw a straight line from each **foodstuff** to the correct **elements** it contains.

foodstuff

carbohydrates

proteins

elements

carbon, hydrogen, oxygen and nitrogen

carbon and hydrogen only

carbon, hydrogen and oxygen

[2]

[Total: 8]

6 Radon gas is given off by the rocks in some parts of Britain.

Radon is a radioactive gas. It gives off alpha radiation.

(a) Ionising radiation can affect cells.

Describe how this happens and what the effects may be on cells.

In your answer refer to

- the effect of ionising radiation on molecules
- **two** things which may happen to living cells struck by ionising radiation.

.....

.....

.....

..... [3]

(b) This question is about houses in regions where there is too much radon gas.

If the level of radon is too high, there is a health risk, so action must be taken.

The maps show the percentage of houses with a health risk due to radon gas in three different regions of England.





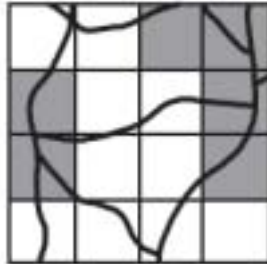

Cambridgeshire

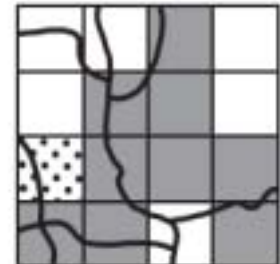

Norfolk



Yorkshire

percentage of houses where action must be taken	
	less than 1%
	between 1% and 3%
	between 3% and 5%
	between 5% and 10%
	more than 10%

Put a tick (✓) in the box for **each** correct region for each statement.

	Cambridgeshire	Norfolk	Yorkshire
One part of this region has very high radon levels.			
Over half of these regions have very low radon levels.			
No area in this region has more than 3% of houses where action must be taken.			

[4]

- (c) Four people who live on one street have been told that their houses are above the level where action must be taken.



- (i) Who thinks there is **no** real risk from radon gas in their house?

Put a tick (✓) in the box next to **each** correct name.

Steve

Debbie

Julian

Marion

[2]

- (ii) Who is planning to make a change to their house to reduce the risk from radon gas?

Put a tick (✓) in the box next to the **one** correct name.

Steve

Debbie

Julian

Marion

[1]

[Total: 10]

7 The following block diagram shows how electricity is made in a nuclear power station.

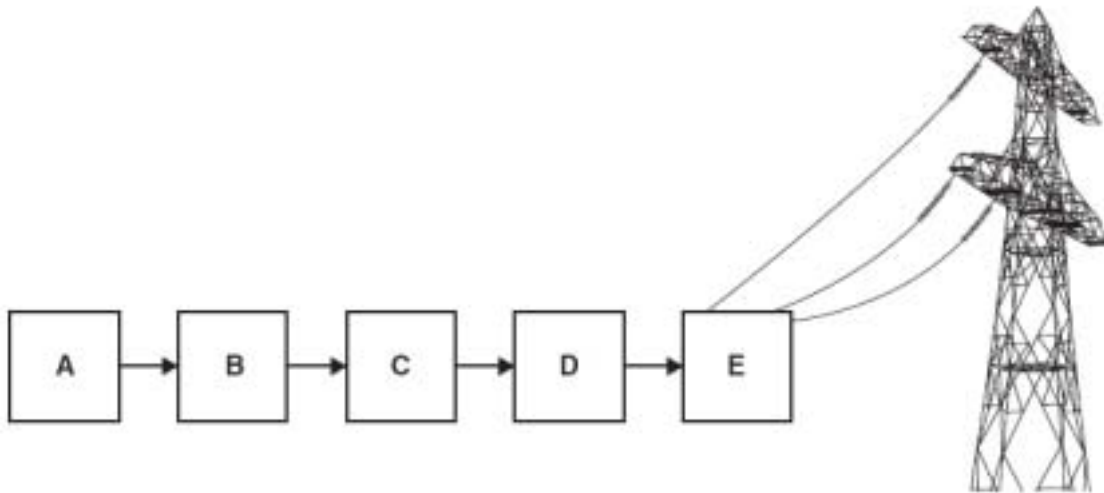

The statements in the table describe what happens at each stage.

They are in the wrong order.

Write the **correct** letter, **B**, **C**, **D** or **E**, next to each stage.

The first stage, **A**, has been put in for you.

Steam turns a turbine.	
Water is heated and changes to steam.	
The turbine turns a generator to make electricity.	
Nuclear changes release heat energy.	A
A transformer sends electricity to the National Grid.	

[3]

[Total: 3]

END OF QUESTION PAPER

PLEASE DO NOT WRITE ON THIS PAGE

Copyright Acknowledgements:

Q.2 table Adapted from Benjamin Wielgosz, Like shooting fish in a barrel, August 2005 © Sustain, www.sustainweb.org
Q.6 maps Adapted from B M R Green, J C H Miles, E J Bradley, and D M Rees, Radon Atlas of England and Wales
(NRPB-W26), November 2002 © Health Protection Agency, www.hpa.org.uk

Permission to reproduce items where third-party owned material protected by copyright is included has been sought and cleared where possible. Every reasonable effort has been made by the publisher (OCR) to trace copyright holders, but if any items requiring clearance have unwittingly been included, the publisher will be pleased to make amends at the earliest possible opportunity.

OCR is part of the Cambridge Assessment Group. Cambridge Assessment is the brand name of University of Cambridge Local Examinations Syndicate (UCLES), which is itself a department of the University of Cambridge.



CONFIDENTIAL

GCSE Unit

MARK SCHEME

SAMPLE ASSESSMENT MATERIAL
(from 2010 onwards)

Science A (J630)
Modules B3, C3 and P3
Foundation Tier

A213/01

Maximum Mark: 42

Guidance for Examiners

Additional Guidance within any mark scheme takes precedence over the following guidance.

1. Mark strictly to the mark scheme.
2. Make no deductions for wrong work after an acceptable answer unless the mark scheme says otherwise.
3. Accept any clear, unambiguous response which is correct, e.g. mis-spellings if phonetically correct (but check additional guidance).
4. Abbreviations, annotations and conventions used in the detailed mark scheme:

/	= alternative and acceptable answers for the same marking point
(1)	= separates marking points
not/reject	= answers which are not worthy of credit
ignore	= statements which are irrelevant - applies to neutral answers
allow/accept	= answers that can be accepted
(words)	= words which are not essential to gain credit
<u>words</u>	= underlined words must be present in answer to score a mark
ecf	= error carried forward
AW/owtte	= alternative wording
ORA	= or reverse argument

E.g. mark scheme shows 'work done in lifting / (change in) gravitational potential energy' (1)

work done = 0 marks

work done lifting = 1 mark

change in potential energy = 0 marks

gravitational potential energy = 1 mark

5. If a candidate alters his/her response, examiners should accept the alteration.
6. Crossed out answers should be considered only if no other response has been made. When marking crossed out responses, accept correct answers which are clear and unambiguous.
7. The list principle:
If a list of responses greater than the number requested is given, work through the list from the beginning. Award one mark for each correct response, ignore any neutral response, and deduct one mark for any incorrect response, e.g. one which has an error of science. If the number of incorrect responses is equal to or greater than the number of correct responses, no marks are awarded. A neutral response is correct but irrelevant to the question.

8. Marking method for tick boxes:

Always check the additional guidance.

If there is a set of boxes, some of which should be ticked and others left empty, then judge the entire set of boxes.

If there is at least one tick, ignore crosses. If there are no ticks, accept clear, unambiguous indications, e.g. shading or crosses.

Credit should be given for each box correctly ticked. If more boxes are ticked than there are correct answers, then deduct one mark for each additional tick. Candidates cannot score less than zero marks.

E.g. If a question requires candidates to identify a city in England, then in the boxes

Edinburgh	
Manchester	
Paris	
Southampton	

the second and fourth boxes should have ticks (or other clear indication of choice) and the first and third should be blank (or have indication of choice crossed out).

Edinburgh			✓			✓	✓	✓	✓	
Manchester	✓	x	✓	✓	✓				✓	
Paris				✓	✓		✓	✓	✓	
Southampton	✓	x		✓		✓	✓		✓	
Score:	2	2	1	1	1	1	0	0	0	NR

Question		Expected Answers	Marks	Rationale
1	a	receptor stimuli nervous	3	One mark for each correct response Accept incorrect spelling if intention clear More than one response from the list in any space =0. Ignore words not from list
	b	some individuals have eyes that focus/work better; individuals with better eyes are more likely to find food/escape predation/find mates/survive; so individuals with better eyes are more likely to breed and pass on genes; over many generations the eyes slowly improve;	4	
Total			7	

2	a	herring	1	One mark for correct response Accept incorrect spelling if intention clear More than one response from the list =0. Ignore words not from list				
	b	Fran	1	One mark for correct response Accept incorrect spelling if intention clear More than one response from the list =0. Ignore words not from list				
	c	i	1	One mark for correct response More than one response = 0				
		food chains always start with plants <table border="1" style="display: inline-table; vertical-align: middle;"> <tr><td> </td></tr> <tr><td> </td></tr> <tr><td>✓</td></tr> <tr><td> </td></tr> </table>			✓		1	One mark for correct response More than one response = 0
✓								
		fewer mackerel <table border="1" style="display: inline-table; vertical-align: middle;"> <tr><td>✓</td></tr> <tr><td> </td></tr> <tr><td> </td></tr> </table>	✓			1	One mark for correct response More than one response = 0	
✓								
Total			4					

Question		Expected Answers		Marks	Rationale										
3	a	Upright man Heidelberg man Neanderthal man Modern man	<table border="1"> <thead> <tr> <th>extinct</th> <th>not extinct</th> </tr> </thead> <tbody> <tr> <td>✓</td> <td></td> </tr> <tr> <td>✓</td> <td></td> </tr> <tr> <td>✓</td> <td></td> </tr> <tr> <td></td> <td>✓</td> </tr> </tbody> </table>	extinct	not extinct	✓		✓		✓			✓	1	One mark for a correct response in BOTH columns Ignore any further correct responses Any incorrect response given = 0 mark Accept any clear statement e.g. ✓ or x or shading etc. Ignore x if combination of ✓ and x used
extinct	not extinct														
✓															
✓															
✓															
	✓														
	b	Upright man	<table border="1"> <tbody> <tr> <td>✓</td> </tr> <tr> <td></td> </tr> <tr> <td></td> </tr> <tr> <td></td> </tr> </tbody> </table>	✓				1	One mark for correct response More than one response = 0						
✓															
	c	A and C		1	both needed for one mark Any order is acceptable										
		Total		3											

Question		Expected Answers	Marks	Rationale												
4	a	salt	1	Accept any clear indication of correct response More than one response = 0												
	b	i														
		<table border="1"> <tr> <td></td> <td>high</td> <td>low</td> </tr> <tr> <td>sugar</td> <td></td> <td>✓</td> </tr> <tr> <td>fat</td> <td>✓</td> <td></td> </tr> <tr> <td>salt</td> <td>✓</td> <td></td> </tr> </table>		high	low	sugar		✓	fat	✓		salt	✓		2	3 correct = 2 marks 1 or 2 correct = 1 mark Accept any clear statement e.g. ✓ or x or shading etc. Ignore x if combination of ✓ and x used
	high	low														
sugar		✓														
fat	✓															
salt	✓															
		ii														
		<p>does not know the outcomes amount of crisps that she eats</p> <table border="1"> <tr><td></td></tr> <tr><td>✓</td></tr> <tr><td>✓</td></tr> <tr><td></td></tr> </table>		✓	✓		2	One mark for each correct response If more than 2 responses given, deduct one mark for each incorrect response								
✓																
✓																
	c	there is a (positive) correlation between a high fat diet and the risk of heart disease; whilst the correlation is true for large numbers of people there will be exceptions/not a perfect correlation	2													
		Total	7													

Question		Expected Answers	Marks	Rationale								
5	a	nitrogen compounds fungal disease manure <table border="1" style="display: inline-table; vertical-align: middle;"> <tr> <td>increases</td> <td>decreases</td> </tr> <tr> <td style="text-align: center;">✓</td> <td></td> </tr> <tr> <td></td> <td style="text-align: center;">✓</td> </tr> <tr> <td style="text-align: center;">✓</td> <td></td> </tr> </table>	increases	decreases	✓			✓	✓		1	all 3 correct for one mark Any extra responses = 0 Accept any clear statement e.g. ✓ or x or shading etc. Ignore x if combination of ✓ and x used
increases	decreases											
✓												
	✓											
✓												
	b	For pesticides will kill pests/improve yield/make disease less likely Against less food for other insects/non-pest insects may be killed/pesticide (residue) may remain on crops/in soil/ farmer cannot sell crop as “organic”	3	maximum one mark for For and one for Against Reason for; (1) Reason against; (1) Consistent conclusion; (1)								
	c	aflatoxin from mould (1) herbicide (1)	2	One mark for each correct response Accept any clear indication of correct response If more than 2 responses given, deduct one mark for each incorrect response								
	d	<pre> graph LR C[carbohydrates] --- E1[carbon, hydrogen, oxygen & nitrogen] P[proteins] --- E2[carbon, hydrogen and oxygen] </pre>	2	one mark for each correct link 2 lines from box on left loses mark for that link								
Total			8									

Question		Expected Answers	Marks	Rationale												
6	a	ionising radiation is able to break molecules up/into bits/into ions; ionising radiation can kill cells; ionising radiation can turn cells cancerous/cause cancer	3													
	b	<table border="1"> <thead> <tr> <th>Cambs</th> <th>Norfolk</th> <th>Yorks</th> </tr> </thead> <tbody> <tr> <td>✓</td> <td></td> <td></td> </tr> <tr> <td>✓</td> <td>✓</td> <td></td> </tr> <tr> <td></td> <td>✓</td> <td></td> </tr> </tbody> </table>	Cambs	Norfolk	Yorks	✓			✓	✓			✓		4	<p>Mark each row separately 1st row – 1mark for each correct response (2 responses =0) 2nd row - 1mark for each correct response (3 responses =1) 3rd row - 1mark for each correct response (2 responses =0)</p> <p>Accept any clear statement e.g. ✓ or x or shading etc. Ignore x if combination of ✓ and x used</p>
Cambs	Norfolk	Yorks														
✓																
✓	✓															
	✓															
	c	i	<table border="1"> <tbody> <tr><td></td></tr> <tr><td></td></tr> <tr><td>Julian</td></tr> <tr><td>Marion</td></tr> <tr><td>✓</td></tr> <tr><td>✓</td></tr> </tbody> </table>			Julian	Marion	✓	✓	2	<p>One mark for each correct response If more than 2 responses given, deduct one mark for each incorrect response</p>					
Julian																
Marion																
✓																
✓																
		ii	<table border="1"> <tbody> <tr><td>Steve</td></tr> <tr><td>✓</td></tr> <tr><td></td></tr> <tr><td></td></tr> <tr><td></td></tr> </tbody> </table>	Steve	✓				1	<p>One mark for correct response More than one response = 0</p>						
Steve																
✓																
Total			10													

Question	Expected Answers	Marks	Rationale					
7	<table border="1" style="margin-left: 20px;"> <tr><td>C</td></tr> <tr><td>B</td></tr> <tr><td>D</td></tr> <tr style="background-color: #cccccc;"><td>A</td></tr> <tr><td>E</td></tr> </table>	C	B	D	A	E	3	<p>Shaded box is given on question paper so ignore 4 correct = 3 marks 2 or 3 correct = 2 mark 1 correct = 1 mark</p> <p>[For Braille papers, correct answer is sequence, D,B,A,C,E B before A 1 mark, A before C 1 mark, C before E 1 mark]</p>
C								
B								
D								
A								
E								
	Total	3						
	Section Total	42						