

Friday 22 June 2012 – Afternoon

**GCSE TWENTY FIRST CENTURY SCIENCE
SCIENCE A**

A212/01 Unit 2: Modules B2 C2 P2 (Foundation Tier)

Candidates answer on the Question Paper.
A calculator may be used for this paper.

Duration: 40 minutes

OCR supplied materials:
None

Other materials required:

- Pencil
- Ruler (cm/mm)



Candidate forename		Candidate surname	
--------------------	--	-------------------	--

Centre number						Candidate number				
---------------	--	--	--	--	--	------------------	--	--	--	--

INSTRUCTIONS TO CANDIDATES

- Write your name, centre number and candidate number in the boxes above. Please write clearly and in capital letters.
- Use black ink. HB pencil may be used for graphs and diagrams only.
- Answer **all** the questions.
- Read each question carefully. Make sure you know what you have to do before starting your answer.
- Write your answer to each question in the space provided. Additional paper may be used if necessary but you must clearly show your candidate number, centre number and question number(s).
- Do **not** write in the bar codes.

INFORMATION FOR CANDIDATES

- The number of marks is given in brackets [] at the end of each question or part question.
- The total number of marks for this paper is **42**.
- This document consists of **16** pages. Any blank pages are indicated.

BLANK PAGE

PLEASE DO NOT WRITE ON THIS PAGE

Answer **all** the questions.

1 This is a question about materials used to make fibres.

(a) Which of these materials is synthetic?

Put a (ring) around the correct answer.

cotton nylon silk wool

[1]

(b) Fibres are often made from the chemicals in crude oil.

Complete each sentence by choosing the **best** word from this list.

burned

carbon

hydrocarbons

hydrogen

polymers

reacted

refined

Crude oil is a mixture of

Crude oil is to make fuels and raw materials for chemical synthesis.

Fibres are made by joining together small molecules to make long chain molecules called

.....

[3]

(c) Crude oil is used to make fuels and lubricants, and is used for chemical synthesis.

What percentage of crude oil is used for chemical synthesis?

Put a (ring) around the correct answer.

4 50 75 95

[1]

[Total: 5]

2 This question is about glass and plastic beakers used for drinks.

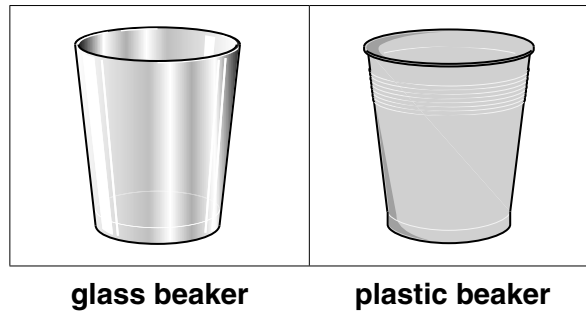

The table shows the energy used, and the greenhouse gases made, at different stages of the life cycle for a glass beaker and a plastic beaker.

	Glass		Plastic	
	Energy used in MJ	Greenhouse gases made in g of CO ₂	Energy used in MJ	Greenhouse gases made in g of CO ₂
Making the beakers from the raw materials	4.4	1.6	5.4	2.0
Transporting the beakers to the shops	3.0	2.1	1.2	0.8
Recycling the beakers	4.5	1.5	1.8	0.5

(a) Use the information in the table to find out if the following statements are **true** or **false**.

Put a tick (✓) in the correct box next to each statement.

	true	false
The energy used for a glass beaker over these three stages is 11.9MJ.	<input type="checkbox"/>	<input type="checkbox"/>
More energy is used for a glass beaker over these three stages than for a plastic beaker.	<input type="checkbox"/>	<input type="checkbox"/>
Less greenhouse gases are made when recycling a glass beaker than when recycling a plastic one.	<input type="checkbox"/>	<input type="checkbox"/>

[2]

(b) If the beakers are not recycled then they are dumped into a landfill site.

Recycling uses **more** energy than dumping into a landfill site.

Recycling makes **more** pollution than dumping into a landfill site.

Explain why many people think that it is better to recycle the beakers than to dump them into a landfill site.

.....

.....

.....

.....

..... [2]

[Total: 4]

3 Rebecca investigates how the length of a polymer strip changes as the mass hanging on it increases.

She hangs a 100 g mass on the end of a polymer strip, as shown in the diagram.

She measures the increase in length (stretch) of the polymer strip.

She adds another 100 g mass and measures the stretch again.

She repeats this until the total mass is 700 g.

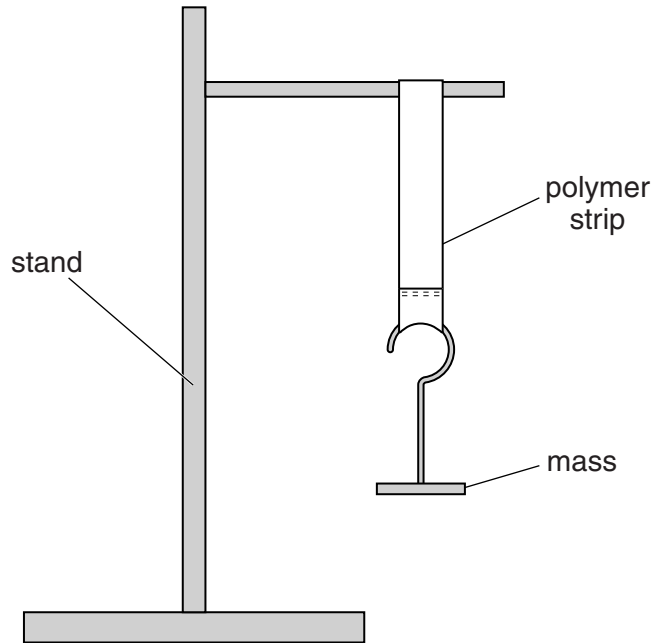

Look at the graph of Rebecca's results.

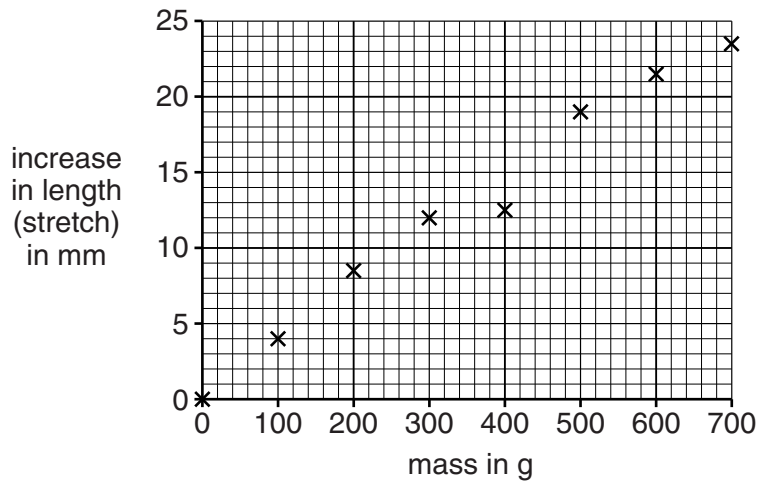

Use the graph to answer these questions.

(a) (i) What is the increase in length when a 100 g mass is used?

..... mm
[1]

(ii) What is the largest stretch shown on the graph?

..... mm
[1]

(b) (i) One of the points on the graph is an outlier.

Draw a ring around the outlier on the graph.

[1]

(ii) Why do you think it is an outlier?
Suggest what Rebecca can do about this outlier.

.....

.....

.....

.....

..... [2]

[Total: 5]

4 Microwave ovens and mobile phones both use microwaves.

(a) Microwave ovens are **not** dangerous to the user.

Which of the following statements explains why?

Put a tick (✓) in the box next to the correct answer.

The user never goes near the microwave oven.

The walls and door of the oven stop microwaves escaping.

Microwaves are part of the electromagnetic spectrum.

Microwave ovens heat food very quickly.

[1]

(b) Microwave ovens heat food very quickly. Mobile phones cannot be used to cook food.

Explain

- how microwaves heat food
- why mobile phones cannot cook food.

.....

.....

..... [2]

[Total: 3]

5 This question is about electromagnetic radiation travelling from the Sun to the surface of the Earth. Use words from this list to complete the sentences below.

photons

electrons

waves

absorbed

emitted

deposited

The beam of electromagnetic radiation consists of 'packets' of energy called

.....

Not all of the radiation entering the Earth's atmosphere reaches the surface of the Earth, because

some of it is

[2]

[Total: 2]

6 Read this article.

Everybody likes sunny weather!

Sunlight is a source of natural light and energy. It is good for our general health and makes us feel good.

Although sunbathing may be enjoyable it is important to remember that too much exposure to sunlight is a health hazard. The ultraviolet (UV) radiation in sunlight can harm the skin.

Sunburn often affects skiers, climbers and trekkers in the mountains. The higher you go, the stronger the Sun’s UV rays are.

The Sun’s rays can also pass through water. When swimming, people can underestimate their exposure to sunlight because of the cooling effect of the water.

(a) Which of the following actions protect people against damage caused by sunlight?

Put ticks (✓) in the boxes next to the **two** correct actions.

- Keeping cool by swimming in the sea.
- Putting sun-screen on burnt skin before going to bed.
- Staying indoors in the daytime.
- Sunbathing by the side of a swimming pool.
- Wearing cotton clothes that cover the body.

[2]

(b) Suggest reasons why people go skiing and mountain climbing, even though there is a risk from sunlight.

You should refer to both **risk** and **benefit** in your answer.

.....

.....

.....

.....

.....

.....

..... [3]

[Total: 5]

7 The diagram shows energy transfers related to global warming.

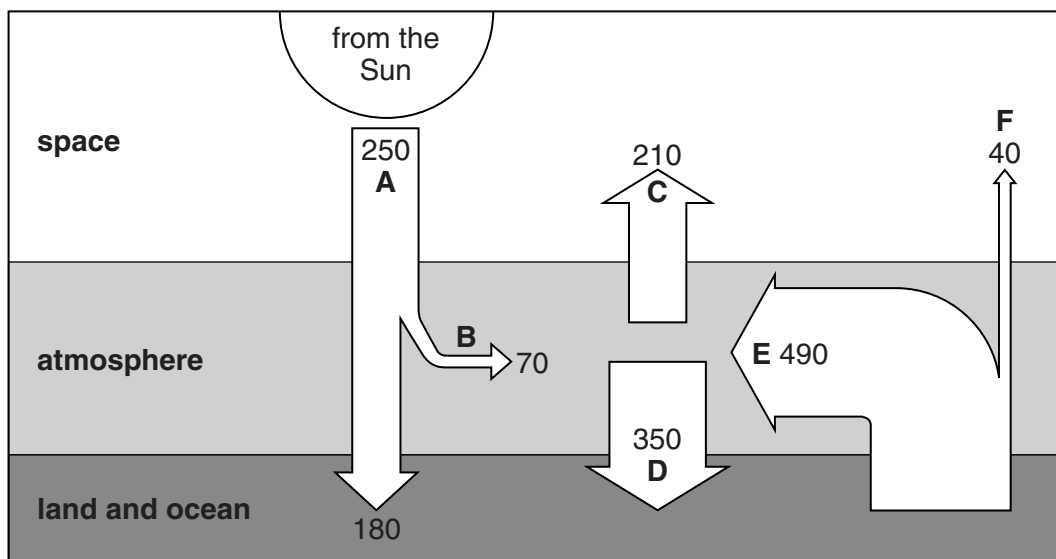

The numbers on the diagram represent the amount of energy transferred in joules per m² per second, averaged over 24 hours. For example, the average energy from the Sun (**A**) reaching the top of the Earth's atmosphere is 250 joules per m² per second.

(a) (i) What is the total energy, in joules per m² per second, emitted into space?

Put a **ring** around the correct answer.

- 40 70 210 250 490

[1]

(ii) What is the total energy, in joules per m² per second, reaching the land and ocean?

Put a **ring** around the correct answer.

- 40 180 350 490 530

[1]

(b) If the concentration of greenhouse gases in the atmosphere increases, some of the energy transfer values will change causing the atmosphere to warm up.

(i) The atmosphere warms up but the energy from the Sun stays the same.

This is because **two** of **A, B, C, D, E** and **F** have increased.

Which **two**?

answer and [1]

(ii) Which **one** of **A, B, C, D, E** and **F** is unaffected by the concentration of greenhouse gases?

answer [1]

[Total: 4]

Turn over

- 8 (a) Antibiotics have to be tested before they can be prescribed by doctors.

Human trials are carried out on healthy volunteers and volunteers with the illness.

For each type of volunteer, what are the antibiotics tested for?

Put a tick (✓) in the correct box in each row to show whether the antibiotic is tested for **effectiveness only**, for **safety only** or for **effectiveness and safety**.

Volunteer	The antibiotic is tested for ...		
	... effectiveness only.	... safety only.	... effectiveness and safety.
healthy			
ill			

[2]

- (b) Bacteria can become resistant to antibiotics.

What can we do to help prevent this?

Put ticks (✓) in the boxes next to the **two** correct answers.

Always complete a course of treatment.

Only take antibiotics when necessary.

Stop taking antibiotics when you feel better.

Take antibiotics for all illnesses.

Test antibiotics on animals before giving them to humans.

[2]

[Total: 4]

9 (a) A system in Fred's body has cells that destroy microorganisms.

What is this system called?

Put a ring around the correct answer.

excretory immune nervous sensory

[1]

(b) Vaccinations provide protection against diseases.

What does a vaccination contain?

.....
..... [2]

(c) Fred has many vaccinations before he starts school.

The table shows the vaccinations given to Fred in the first three years of his life.

Diseases vaccinated against
polio
diphtheria
tetanus
measles
mumps
rubella

(i) Explain why Fred needs different vaccinations.

.....
.....
.....
.....
..... [2]

(ii) When Fred is 13 years old, he needs to be vaccinated against tetanus again.

Suggest why Fred needs more than one vaccination against tetanus.

.....
..... [1]

(d) Some people think that vaccinations should be made compulsory.

What reason could they give for this?

Put a tick (✓) in the box next to the correct answer.

There are side-effects that could be harmful for some people.

It would prevent large numbers of people from getting the disease.

Individuals may get the disease.

Some children who are vaccinated will get a mild form of the disease.

[1]

[Total: 7]

10 This question is about heart disease.

(a) Complete these sentences about the heart.

The heart needs its own blood supply to provide for the muscle cells and remove from the muscle cells.

A build up of in the arteries supplying the heart muscle can cause a heart attack. [2]

(b) Jane visits her doctor.

She is advised to make changes to her lifestyle to reduce the risk of a heart attack.

Put a tick (✓) in the correct box for each row to show if the lifestyle factor increases or decreases the risk.

Lifestyle factor	Increases risk	Decreases risk
excessive alcohol intake		
regular exercise		
diet high in saturated fat		
smoking		
stress		

[1]

[Total: 3]

END OF QUESTION PAPER

PLEASE DO NOT WRITE ON THIS PAGE



Copyright Information

OCR is committed to seeking permission to reproduce all third-party content that it uses in its assessment materials. OCR has attempted to identify and contact all copyright holders whose work is used in this paper. To avoid the issue of disclosure of answer-related information to candidates, all copyright acknowledgements are reproduced in the OCR Copyright Acknowledgements Booklet. This is produced for each series of examinations and is freely available to download from our public website (www.ocr.org.uk) after the live examination series.

If OCR has unwittingly failed to correctly acknowledge or clear any third-party content in this assessment material, OCR will be happy to correct its mistake at the earliest possible opportunity.

For queries or further information please contact the Copyright Team, First Floor, 9 Hills Road, Cambridge CB2 1GE.

OCR is part of the Cambridge Assessment Group; Cambridge Assessment is the brand name of University of Cambridge Local Examinations Syndicate (UCLES), which is itself a department of the University of Cambridge.