

Answer **all** the questions.

1 Bob builds this simple signalling circuit.

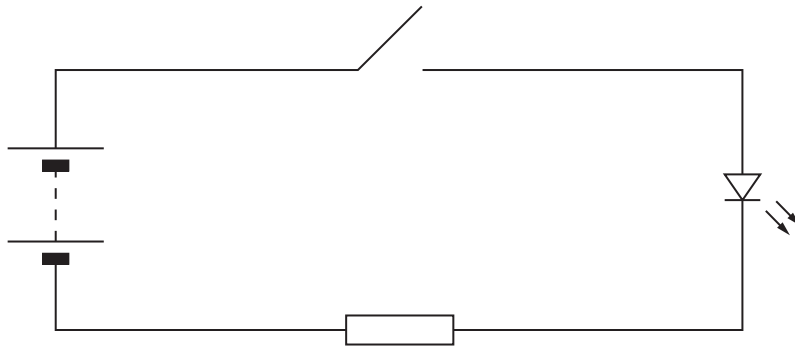

(a) The circuit contains an LED.

Put a ring around the LED.

[1]

(b) Bob presses the switch to make the LED glow.

Complete this block diagram for the signalling circuit.

Choose from these words.

battery

LED

resistor

switch

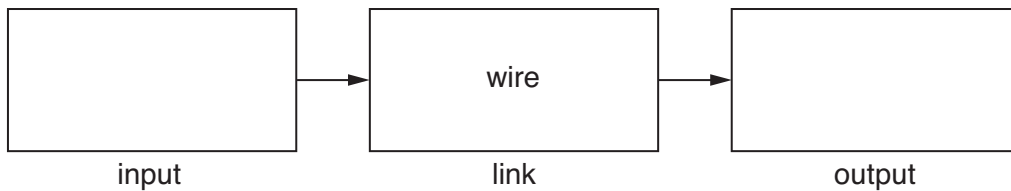

[2]

(c) Bob uses the circuit to communicate with Sally in another room.

He uses Morse code.

Draw lines to connect the **start** of each sentence to its correct **end**.

start

end

The error rate is ...

... the distance between Bob and Sally.

The transmission rate is ...

... how many mistakes Bob makes in each minute.

The range of the system is ...

... how many characters Bob sends in each minute.

[2]

(d) The long and short flashes of light from the LED are a visual code.

Each letter has a different pattern of long and short flashes.

State **another** example of a system which uses a visual code.

Describe how the code works.

.....

.....

.....

..... [2]

[Total: 7]

2 Saleem has a wireless printer for his computer system.

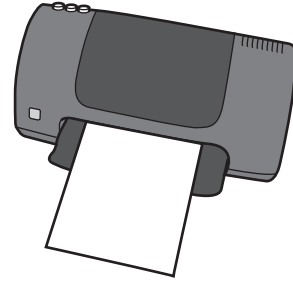

(a) The computer and printer are not linked by a cable.

What is the link which connects the computer to the printer?

Put a (ring) around the answer.

copper wire

optical fibre

radio waves

[1]

(b) The sentences below explain how the computer sends a document to the printer.

Complete the sentences. Choose from these words.

demodulates

modulates

transmits

receives

The computer first the signal onto a carrier wave.

The computer then the carrier wave to the printer.

The printer first the carrier wave from the computer.

The printer then the carrier wave to extract the signal.

[3]

(c) The printer has a large memory.

This stores digital information as it arrives from the computer.

State **two** other devices which can store digital information.

.....

..... [2]

[Total: 6]

5
BLANK PAGE

PLEASE DO NOT WRITE ON THIS PAGE

- 3 Pete is a policeman. He uses the radio in his car to communicate with other police.



- (a) Pete's messages are secret. They can only be understood by other police.

What is the process used by the radio to keep his messages secret?

Put a ring around the correct answer.

absorption

compression

encryption

transmission

[1]

- (b) Pete's radio can receive video signals and display them on a screen.

Here are some statements about video pictures on a screen.

Put ticks (✓) in the boxes next to the **two** correct statements.

Each frame is made from rows of pixels.

Each pixel is made from rows of frames.

Each row is made from frames of pixels.

The video signal sets the brightness of each pixel.

The refresh rate sets the number of rows in a frame.

[2]

(c) Pete makes sure that his radio is tuned to 75.65 MHz each time he starts work.

(i) Suggest why he needs to do this.

.....
 [1]

(ii) The police authority has a licence to use the frequency 75.65 MHz.

Who issues the licence? Put a (ring) around the answer.

the BBC

the Government

the Armed Forces

the manufacturer of the radio sets

[1]

(d) Draw lines to link each **radio frequency** with its **use**.

radio frequency

use

1 MHz

Bluetooth

100 MHz

FM broadcasts

2.4 GHz

MW broadcasts

[2]

[Total: 7]

4 Here is the block diagram for a simple television system.

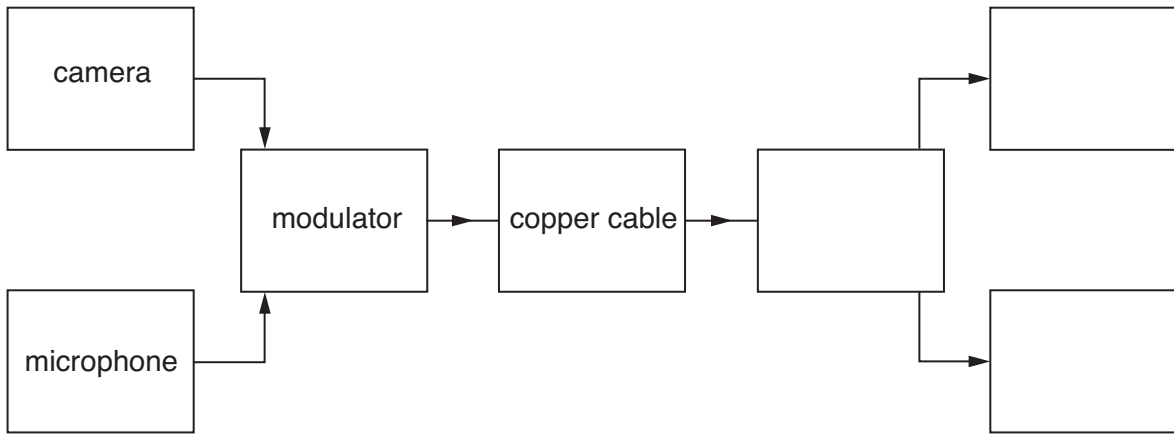

(a) Complete the block diagram for a television system. Choose from these words.

demodulator

loudspeaker

printer

screen

[2]

(b) The modulator converts the analogue signal from the microphone into a digital signal before it is sent down the copper wire. The sentences describe how this is done.

- A** The analogue signal is sampled.
- B** The word is sent out as a series of bits.
- C** The voltage is converted into a binary word.
- D** The voltage of the sample is measured.

Complete the table to show the correct order of the sentences.

A			
----------	--	--	--

[1]

(c) The video signal from the camera is sent down the copper wire as an analogue signal.

What are the advantages of using **analogue** signals instead of digital signals?

Put ticks (✓) in the boxes next to the **two** correct statements.

Analogue signals travel faster than digital ones.

Analogue signals can go further than digital ones.

The circuits needed for analogue circuits are simpler.

Analogue signals suffer less loss of quality than digital ones.

Analogue signals carry all of the information from the camera.

[2]

[Total: 5]

5 Here is an oscilloscope trace of a digital signal.

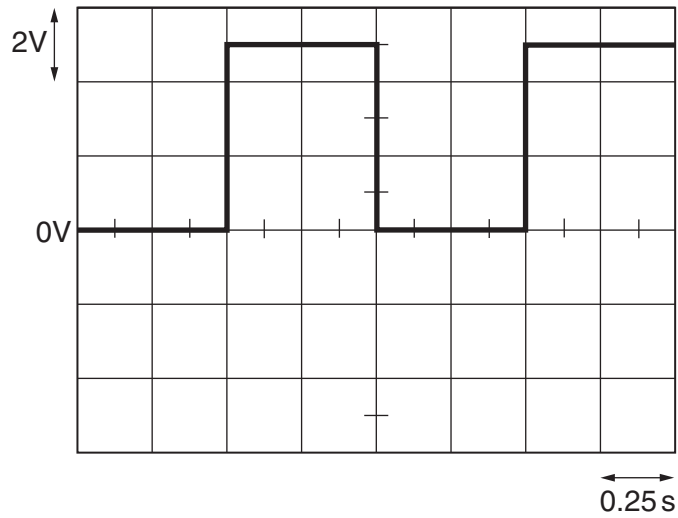

(a) How can you tell that the signal is a **digital** one?

.....
 [1]

(b) The oscilloscope is set up with 0V at the centre of the screen.

Calculate the maximum voltage of the signal.

maximum voltage = V [1]

(c) Calculate the time for one cycle (period) of the signal on the screen.

Then draw one straight line to link your value of the **period** to its **frequency**.

period	frequency
0.25s	0.5Hz
0.50s	1.0Hz
1.00s	2.0Hz
2.00s	4.0Hz

[2]

(d) Digital signals are used a lot in communications.

This is because they do not lose their quality as they travel.

State **two** other advantages of using digital signals for communication.

.....

.....



.....

..... [2]

[Total: 6]

6 Jim plans to buy a new radio receiver.

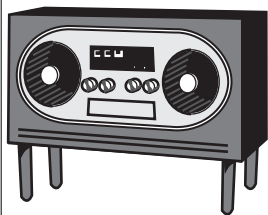
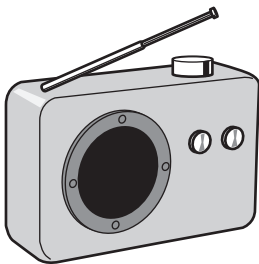
(a) He finds these details in a catalogue.

receiver name	AW36	LH56	ZB02	SD99
cost	£42	£32	£36	£27
size	stand alone 	table top 	table top 	pocket 
weight	75 N	20 N	15 N	2 N
channels	DAB only	LW, MW and FM	FM only	MW and FM
power source	mains	mains or battery	battery	battery
sound power	42 W	10 W	1.5 W	0.1 W

(i) Jim wants a radio that he can easily carry around with him.

Which one should he choose? Give **two** reasons for your answer.

.....

.....

..... [1]

(ii) Jim wants a receiver which is cheap to run and picks up FM channels.

Which receiver should he choose? Give a reason for your answer.

.....

..... [1]

(b) Here is a block diagram for a radio receiver.



(i) Complete the diagram. Choose from these words.

amplifier demodulator microphone modulator tuner

[2]

(ii) What do the arrows in the diagram represent?

.....
..... [1]

[Total: 5]

END OF QUESTION PAPER

14
BLANK PAGE

PLEASE DO NOT WRITE ON THIS PAGE

15
BLANK PAGE

PLEASE DO NOT WRITE ON THIS PAGE

PLEASE DO NOT WRITE ON THIS PAGE



Copyright Information

OCR is committed to seeking permission to reproduce all third-party content that it uses in its assessment materials. OCR has attempted to identify and contact all copyright holders whose work is used in this paper. To avoid the issue of disclosure of answer-related information to candidates, all copyright acknowledgements are reproduced in the OCR Copyright Acknowledgements Booklet. This is produced for each series of examinations and is freely available to download from our public website (www.ocr.org.uk) after the live examination series.

If OCR has unwittingly failed to correctly acknowledge or clear any third-party content in this assessment material, OCR will be happy to correct its mistake at the earliest possible opportunity.

For queries or further information please contact the Copyright Team, First Floor, 9 Hills Road, Cambridge CB2 1GE.

OCR is part of the Cambridge Assessment Group; Cambridge Assessment is the brand name of University of Cambridge Local Examinations Syndicate (UCLES), which is itself a department of the University of Cambridge.