

GENERAL CERTIFICATE OF SECONDARY EDUCATION

TWENTY FIRST CENTURY SCIENCE

A336/01

ADDITIONAL APPLIED SCIENCE A

Materials and Performance (Foundation Tier)

Wednesday 22 June 2011

Morning

Duration: 45 minutes

Candidates answer on the question paper.
A calculator may be used for this paper.

OCR supplied materials:

None

Other materials required:

- Pencil
- Ruler (cm/mm)



Candidate forename		Candidate surname	
-----------------------	--	----------------------	--

Centre number						Candidate number				
---------------	--	--	--	--	--	------------------	--	--	--	--

INSTRUCTIONS TO CANDIDATES

- Write your name, centre number and candidate number in the boxes above. Please write clearly and in capital letters.
- Use black ink. Pencil may be used for graphs and diagrams only.
- Read each question carefully. Make sure you know what you have to do before starting your answer.
- Write your answer to each question in the space provided. Additional paper may be used if necessary but you must clearly show your candidate number, centre number and question number(s).
- Answer **all** the questions.
- Do **not** write in the bar codes.

INFORMATION FOR CANDIDATES

- The number of marks is given in brackets [] at the end of each question or part question.
- The total number of marks for this paper is **36**.
- This document consists of **12** pages. Any blank pages are indicated.

Answer **all** the questions.

1 Mrs Bakewell works in a kitchen. The objects in the kitchen have different **material properties**.

(a) Complete each sentence.

Choose the correct property from this list.

brittle flexible hard stiff weak

A chopping board does not scratch easily. It is

A tray keeps its shape when loaded with plates. It is

[2]

(b) Draw a straight line to link each **object** with the **property** it needs.

object

property

A pan which lets heat pass through quickly.

high thermal conductance

low thermal conductance

A glove for picking up hot pans.

high electrical conductance

low electrical conductance

[2]

(c) Mrs Bakewell chooses a new floor covering for the kitchen. It needs certain properties.

Which properties are the most important for a kitchen floor covering?

Put ticks (✓) in the boxes next to the **two** best properties.

brittle

durable

elastic

non-slip

opaque

[2]

[Total: 6]

2 Lucia works in a large DIY store which sells lamps.

(a) Each lamp has a cable with a plug.

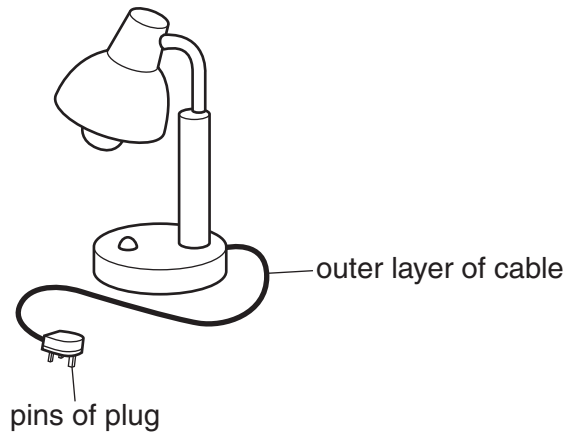

The cable and the plug need the right **electrical** and **mechanical** properties.

Complete the table to show the properties.

Choose properties from this list.

brittle dense rigid conductor insulator flexible translucent

part of lamp	electrical property	mechanical property
outer layer of cable		
pins of plug		

[3]

(b) The store sells wall mirrors for decoration.

Write down **another** example of the use of mirrors.

.....

..... [1]

(c) The store sells specialised glass.

Here are four uses of specialised glass.

Give a reason why each **specialised glass** is needed.

use	specialised glass	reason for using this type of glass
for a glass door	toughened
for a bathroom window	translucent
a window in a tall building	self-cleaning glass
a stained glass window	tinted

[4]

(d) The store sells garden equipment.

Lucia chooses a trellis to support her plants.

She wants the trellis to be **rigid** for good support.

Lucia compares the size and structure of each trellis in the store.

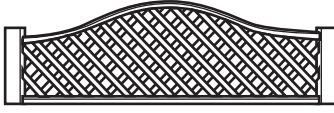
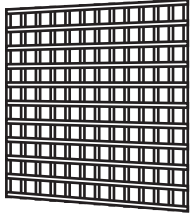
		
<p>tall, narrow trellis thin pieces of wood</p>	<p>short, wide trellis thick pieces of wood</p>	<p>tall, wide trellis thin pieces of wood</p>
<p>A</p>	<p>B</p>	<p>C</p>

Which trellis, **A**, **B** or **C**, is the most rigid?

answer [1]

[Total: 9]

3 Tim Burrs is a carpenter. He needs to know the properties of wood.

He can then choose wood with the right strength and stiffness.

(a) Give **another** example of a job which needs a good knowledge of material properties.

Give a reason why this knowledge is needed.

.....
..... [1]

(b) Tim builds a framework for a roof.

The roof framework has a safety margin. It can hold more than the weight of the roof.

The roof will not collapse if a person stands on it.

(i) Give another example of a product which needs a safety margin. Explain why the safety margin is needed.

.....
.....
..... [2]

(ii) A building control inspector checks how Tim builds the framework for the roof.

Give **another** example of a job which involves enforcing standards.

..... [1]

(iii) Tim buys building materials which are made according to product standards.

Show the reasons for having product standards.

Put ticks (✓) in the boxes next to the **two** correct reasons.

so products ...

... are safe

... cost less

... look smart

... are in fashion

... are fit for purpose

[2]

(c) The European Community has a mark (CE) to show that a product meets the CE standard. Which of these marks indicate that a product meets a standard?

Draw a ring around each of the **two** correct marks.

BHS

BS

ISA

ISO

PS

PTO

[2]

[Total: 8]

4 Cara finds out how her camera works.

(a) (i) Write the words **aperture** and **shutter** in the correct boxes.

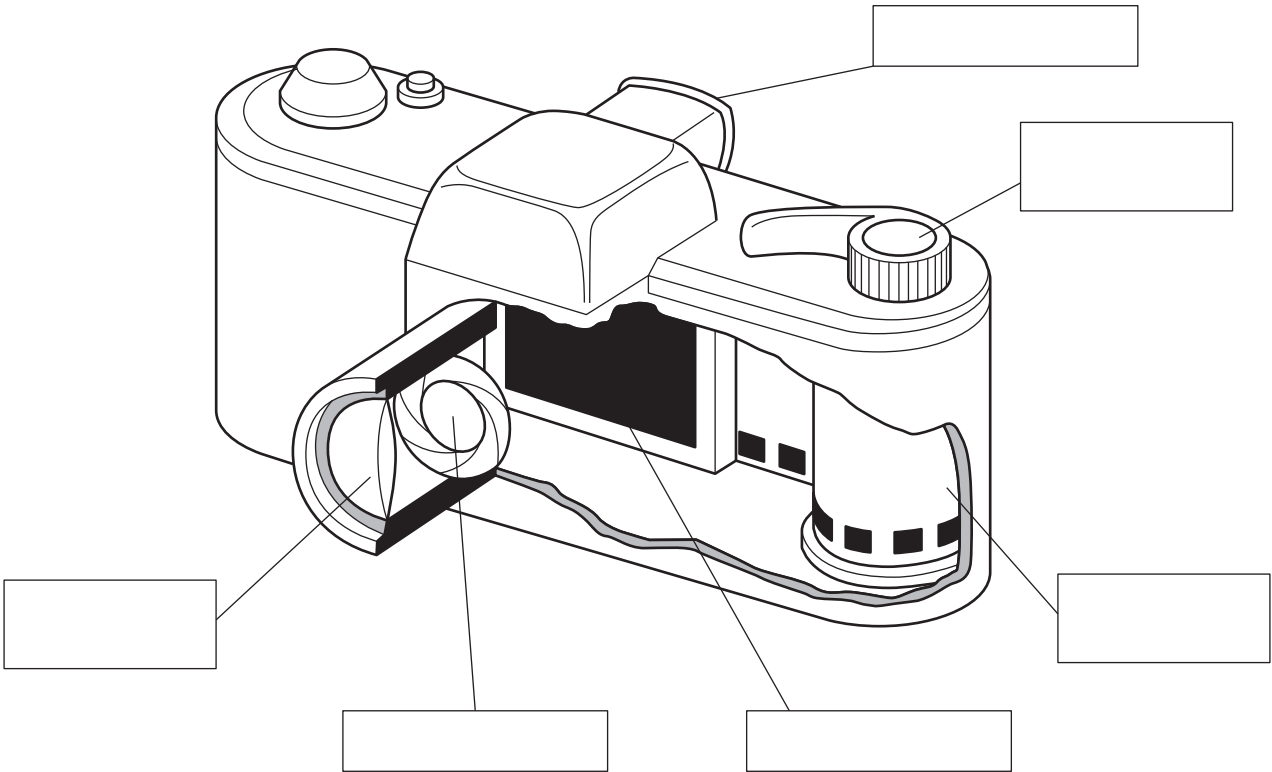

[2]

(ii) Cara learns that the camera lens has a special coating.

State the purpose of this coating.

..... [1]

(b) Parallel rays from a distant object arrive at the lens. They change direction as they pass through the lens.

(i) Name the **process** which makes the rays change direction.

..... [1]

(ii) The change in direction depends on the **power** of the lens.

Write down the unit used for the power of the lens.

..... [1]

(c) The diagram shows how the camera lens focuses parallel rays to make an image.

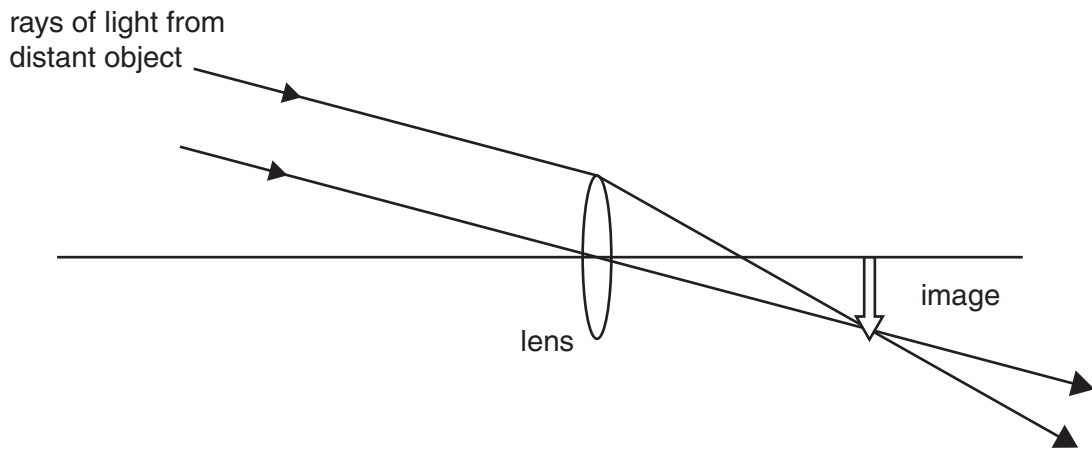

Describe what these words mean. You may draw on the diagram to help your answer.

focal length

focal plane [2]

[Total: 7]

5 (a) Ravi tests how tightening spokes affects the stiffness of a bicycle wheel.

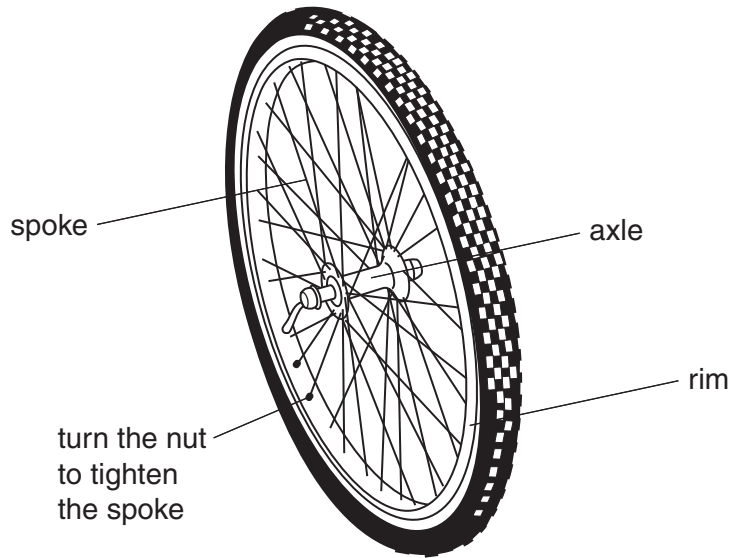

He clamps the axle firmly and uses a force to make the rim bend (deflect) sideways.

He measures the deflection of the rim.

He then tightens all the spokes by one quarter of a turn and measures the deflection.

He repeats this procedure nine times.

He then repeats the whole of the test to check for reliability.

These are his results.

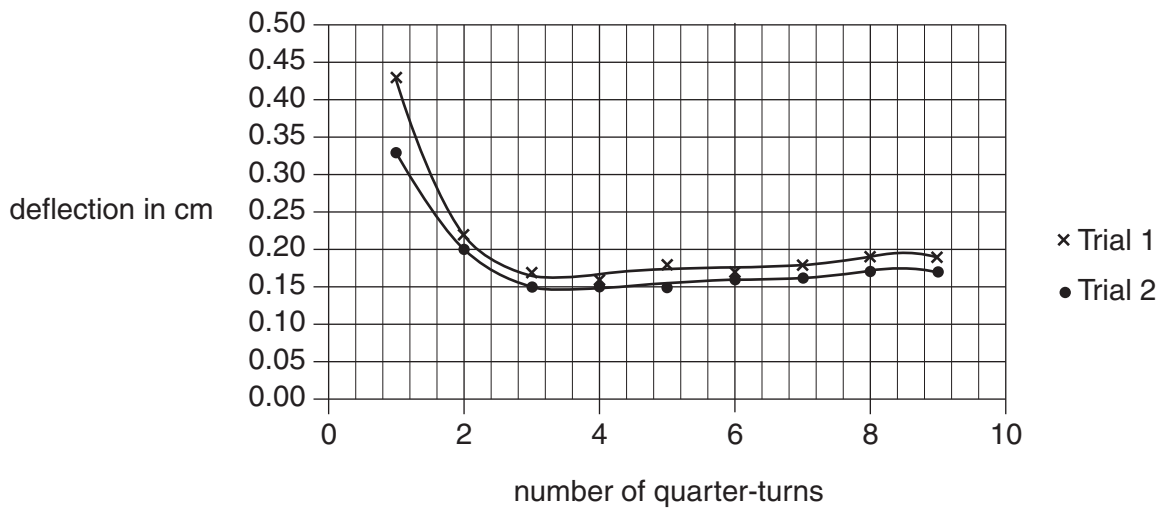

The graph shows that the wheel is flexible if the spokes are loose and stiff if the spokes are tight.

(i) What is the **smallest** number of quarter-turns needed for a stiff wheel?

answer quarter-turns [1]

(ii) Are the results reliable?

Explain your answer.

.....

.....

.....

..... [2]

(b) Describe how you would compare the stiffness of samples in a school laboratory.

You may use a diagram to help your answer.

.....

.....

..... [3]

[Total: 6]

END OF QUESTION PAPER

PLEASE DO NOT WRITE ON THIS PAGE



Copyright Information

OCR is committed to seeking permission to reproduce all third-party content that it uses in its assessment materials. OCR has attempted to identify and contact all copyright holders whose work is used in this paper. To avoid the issue of disclosure of answer-related information to candidates, all copyright acknowledgements are reproduced in the OCR Copyright Acknowledgements Booklet. This is produced for each series of examinations and is freely available to download from our public website (www.ocr.org.uk) after the live examination series.

If OCR has unwittingly failed to correctly acknowledge or clear any third-party content in this assessment material, OCR will be happy to correct its mistake at the earliest possible opportunity.

For queries or further information please contact the Copyright Team, First Floor, 9 Hills Road, Cambridge CB2 1GE.

OCR is part of the Cambridge Assessment Group; Cambridge Assessment is the brand name of University of Cambridge Local Examinations Syndicate (UCLES), which is itself a department of the University of Cambridge.