

GENERAL CERTIFICATE OF SECONDARY EDUCATION
TWENTY FIRST CENTURY SCIENCE
ADDITIONAL APPLIED SCIENCE A
Materials and Performance (Foundation Tier)

A336/01

Wednesday 27 January 2010
Afternoon

Duration: 45 minutes

Candidates answer on the Question Paper
A calculator may be used for this paper

OCR Supplied Materials:
None

Other Materials Required:

- Pencil
- Ruler (cm/mm)



Candidate Forename		Candidate Surname	
--------------------	--	-------------------	--

Centre Number						Candidate Number				
---------------	--	--	--	--	--	------------------	--	--	--	--

INSTRUCTIONS TO CANDIDATES

- Write your name clearly in capital letters, your Centre Number and Candidate Number in the boxes above.
- Use black ink. Pencil may be used for graphs and diagrams only.
- Read each question carefully and make sure that you know what you have to do before starting your answer.
- Answer **all** the questions.
- Do **not** write in the bar codes.
- Write your answer to each question in the space provided, however additional paper may be used if necessary.

INFORMATION FOR CANDIDATES

- The number of marks is given in brackets [] at the end of each question or part question.
- The total number of marks for this paper is **36**.
- This document consists of **12** pages. Any blank pages are indicated.

Answer **all** the questions.

- 1 (a) Ted is a science teacher. He uses PE equipment to explain the physical properties of materials.

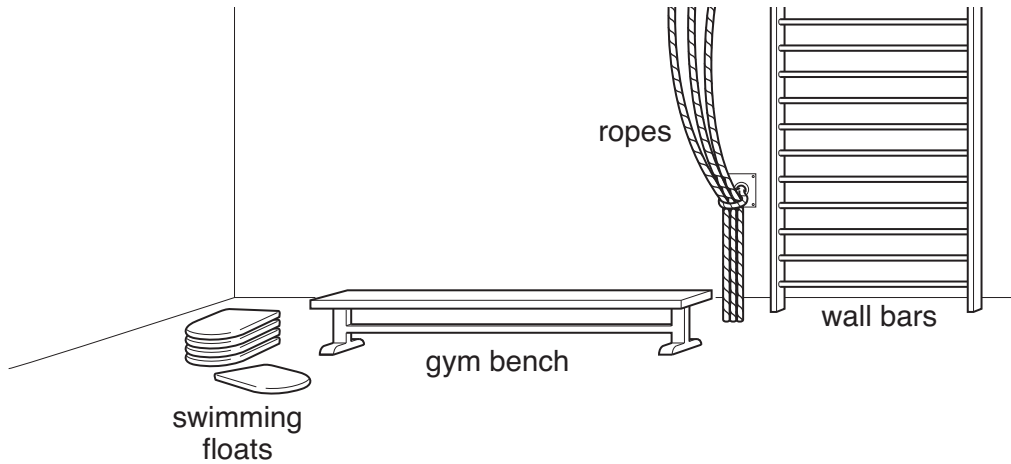

Draw a straight line from each piece of **equipment** to the **material property** it needs.

One is done for you.

equipment	material property
gym bench	brittle
rope	low density
swimming float	flexible
wall bars	hard
	stiff

A straight line is drawn from the 'gym bench' box to the 'hard' box.

[3]

(b) Ted explains the **classes** of materials used to make games equipment.

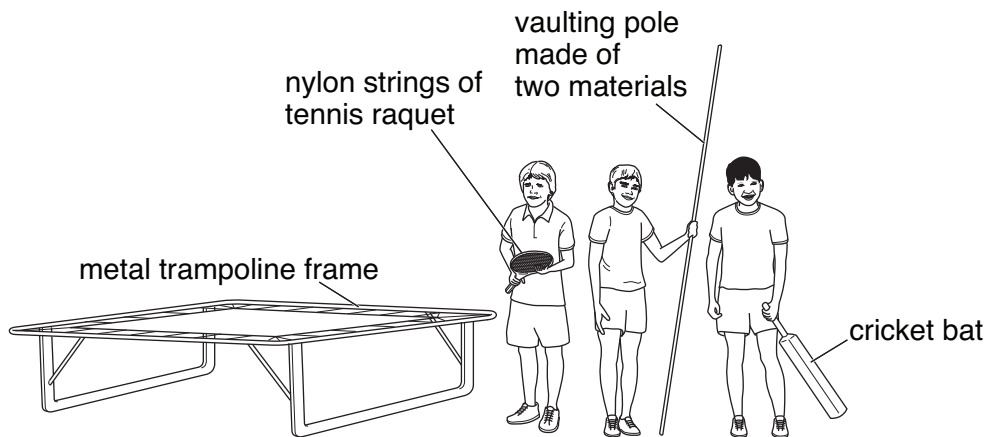

Draw a straight line from each piece of **equipment** to the correct **class** of its material.

equipment

cricket bat

nylon strings of
tennis racquet

vaulting pole made
of two materials

metal trampoline frame

class

alloy

ceramic

composite

polymer

wood

[4]

(c) The stiffness of a tennis racquet frame affects its performance. Describe an experiment to compare the stiffness of tennis racquet frames. Your answer must include:

- how to clamp the frame firmly
- how to apply a force to the frame
- how to measure the change in the shape of the frame.

Use a diagram to help your answer.

.....

.....

..... [3]

[Total: 10]

2 Diane is a physiotherapist. She wants some metal crutches for her patients.

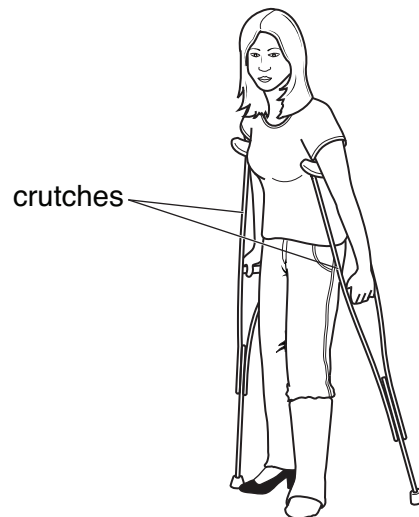

The crutches must be easy to lift and must not be damaged easily.
Which **three** material properties should they have?

Draw straight lines from the word **crutches** to each required material property.

low density

low electrical conductance

high thermal conductance

crutches

strong

stiff

brittle

transparent

[3]

[Total: 3]

3 George works in a dance hall.

(a) (i) He chooses a decoration for the dance hall. There are shiny mirrors on the decoration.

Complete the sentence.

Choose a word from this list.

opaque reflective transparent

The mirrors are shiny because they are [1]

(ii) Mirrors have many uses in buildings other than decoration.

Describe **another** use of a mirror in a building.

.....
..... [1]

(b) When a band plays in the dance hall, the sound may be very loud.

(i) A very loud sound may cause pain.
Here is a list of sound intensities.

Underline **all** of the sound intensities in the list which would cause pain.

Intensity in dB: **0 50 100 150 200** [1]

(ii) George has tinnitus due to hearing too much loud music.

Suggest **another** hearing problem caused by high sound intensities.

..... [1]

(iii) What is the **full name** of the scale used to describe sound intensity?

The scale. [1]

(iv) The windows of the dance hall are double glazed to prevent noise pollution.

Other materials are used in buildings to prevent noise pollution.

Complete this sentence.

Choose words from this list.

absorb amplify reflect

Carpet on the floor is used to sound. [1]

(c) There are electrical cables for the loudspeakers in the dance hall.

(i) The core of the cable is made of copper.

Put a tick (✓) in the box next to the **best** reason for using copper inside the cable.

copper is cheap

copper can be recycled

copper has a low reactivity

copper has a high electrical conductance

[1]

(ii) The outer layer is made of PVC. This needs to be an insulator.

Put a tick (✓) in the box next to the **best** reason for using PVC for the outer layer.

PVC has a low density

PVC can be recycled

PVC can be made in different colours

PVC has a low electrical conductance

[1]

[Total: 8]

4 Robert is a cameraman.

- (a) This diagram shows Robert's camera.
Label the **lens**, **shutter**, **aperture**, and **viewfinder**.

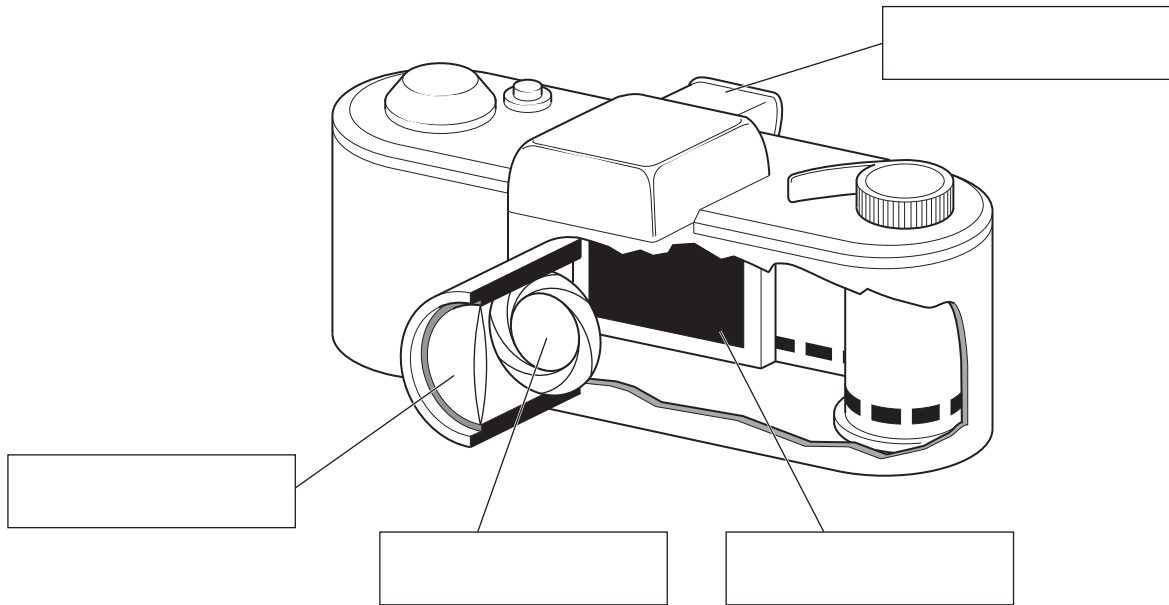

[4]

- (b) There is a converging lens in his camera.

- (i) Which shape of lens, **A**, **B** or **C**, is a converging lens?

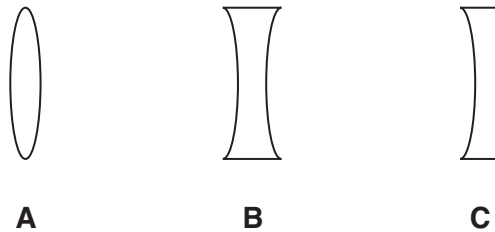

answer [1]

- (ii) Robert explains how the camera lens produces an image.

Complete these sentences. Choose words from this list.

- circle** **eclipse** **focus** **image** **inverted**
line **object** **real** **reflected** **upright** **virtual**

'Parallel rays of light from a distant object are brought to a
on the film. This makes an which is smaller than the
object. It is and

[4]

(iii) The material of the lens makes the light rays change direction.

Give the name of this effect.

answer [1]

(iv) The surface of the lens has a coating.

Describe the purpose of this coating.

.....
..... [1]

[Total: 11]

5 Stefan is a science teacher. He wants his class to compare the expansion of some metal bars.

- (a) He first estimates how much a steel bar will expand.
 The bar is 1.5 m long and Stefan expects its temperature to rise by 400 °C.
 The expansion index of mild steel is 15.

Use the formula below to predict the expansion of the bar.

Show your working.

$$\text{expansion (mm)} = \frac{\text{length of bar (m)} \times \text{temperature rise (}^\circ\text{C)} \times \text{expansion index}}{1000}$$

expansion = mm [2]

- (b) Stefan carries out the same experiment with different metals.

He gets these results.

expansion of metal bar in mm			
metal	test 1	test 2	test 3
aluminium	10	20	12
iron	6.0	7.0	6.5
copper	9.0	10	10
steel	8.0	9.0	10

- (i) The students notice an outlier in the data.

Put a ring around the outlier.

[1]

(ii) Stefan asks his students to write down the metals in order of expansion.

Use the data in the table to write down the metals in order of expansion.

Start with the highest expansion.

highest expansion



lowest expansion

[1]

[Total: 4]

END OF QUESTION PAPER

PLEASE DO NOT WRITE ON THIS PAGE



Copyright Information

OCR is committed to seeking permission to reproduce all third-party content that it uses in its assessment materials. OCR has attempted to identify and contact all copyright holders whose work is used in this paper. To avoid the issue of disclosure of answer-related information to candidates, all copyright acknowledgements are reproduced in the OCR Copyright Acknowledgements Booklet. This is produced for each series of examinations, is given to all schools that receive assessment material and is freely available to download from our public website (www.ocr.org.uk) after the live examination series.

If OCR has unwittingly failed to correctly acknowledge or clear any third-party content in this assessment material, OCR will be happy to correct its mistake at the earliest possible opportunity.

For queries or further information please contact the Copyright Team, First Floor, 9 Hills Road, Cambridge CB2 1GE.

OCR is part of the Cambridge Assessment Group; Cambridge Assessment is the brand name of University of Cambridge Local Examinations Syndicate (UCLES), which is itself a department of the University of Cambridge.