

GENERAL CERTIFICATE OF SECONDARY EDUCATION
TWENTY FIRST CENTURY SCIENCE
ADDITIONAL APPLIED SCIENCE A
Communications (Foundation Tier)

A326/01

Candidates answer on the Question Paper
A calculator may be used for this paper

OCR Supplied Materials:
None

Other Materials Required:

- Pencil
- Ruler (cm/mm)

Wednesday 27 January 2010
Afternoon

Duration: 45 minutes



Candidate Forename		Candidate Surname	
--------------------	--	-------------------	--

Centre Number						Candidate Number				
---------------	--	--	--	--	--	------------------	--	--	--	--

MODIFIED LANGUAGE

INSTRUCTIONS TO CANDIDATES

- Write your name clearly in capital letters, your Centre Number and Candidate Number in the boxes above.
- Use black ink. Pencil may be used for graphs and diagrams only.
- Read each question carefully and make sure that you know what you have to do before starting your answer.
- Answer **all** the questions.
- Do **not** write in the bar codes.
- Write your answer to each question in the space provided, however additional paper may be used if necessary.

INFORMATION FOR CANDIDATES

- The number of marks is given in brackets [] at the end of each question or part question.
- The marks allocated and the spaces provided for your answers are a good indication of the length of answers required.
- The total number of marks for this paper is **36**.
- This document consists of **12** pages. Any blank pages are indicated.

Answer **all** the questions.

1 Joe opens up a computer to repair it.
He sees these two symbols on the cover.

(a) Draw straight lines to link each **symbol** with its correct **meaning**.

symbol

meaning



danger

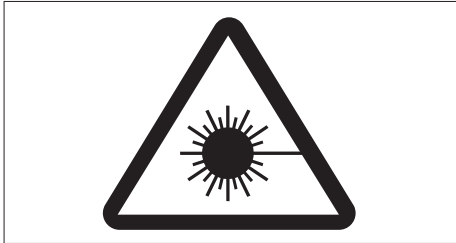

high voltage

laser hazard

[2]

(b) The two symbols above are an example of one type of **shared visual code**.
Give an example of a different type of shared visual code.
State what it does.

.....

.....

..... [2]

(c) Joe studies some technical data about the computer before he opens it.

mains supply	230V, 50 Hz
power output	40W
memory capacity	512 Gbytes

(i) Which piece of data tells Joe about a possible **electrical** hazard?

..... [1]

(ii) Suggest one precaution that Joe could take to reduce the risk from this **electrical** hazard.

.....
..... [1]

[Total: 6]

2 Here is the circuit diagram for a simple signalling system.

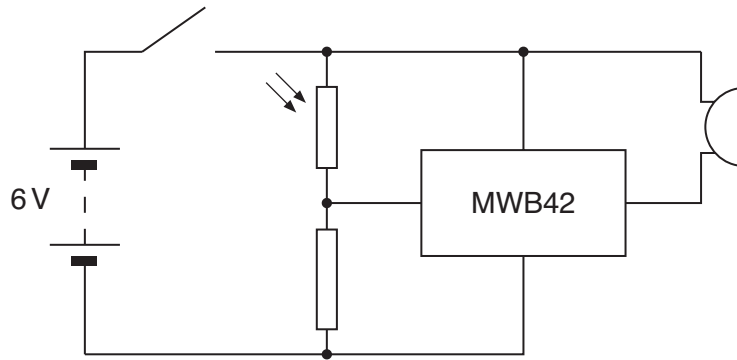

(a) Look at the symbols used in the circuit diagram.
Put a ring around the integrated circuit. [1]

(b) Use the circuit diagram to complete this block diagram.
Choose words from the list.

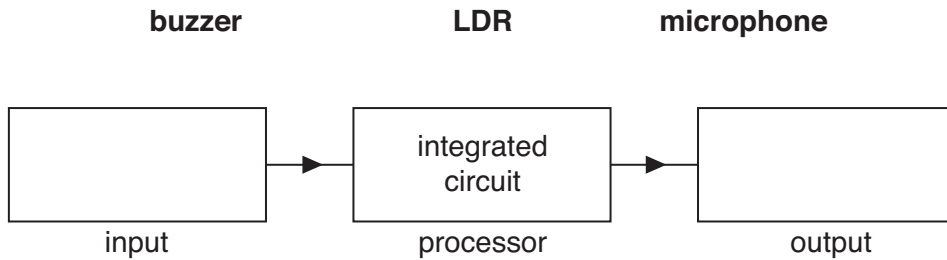

[2]

(c) The maximum current in the integrated circuit is 0.25 A when it runs from a 6 V supply.

(i) Use $P = IV$ to calculate the maximum heating power of the integrated circuit.

heating power = W [1]

(ii) Why is it useful to know the maximum heating power of a component?

.....
..... [1]

(d) A voltmeter is needed to check the voltage across the battery.

Choose the correct meter symbol from the list below.

Draw it connected in the correct place on the circuit diagram at the top of this page.

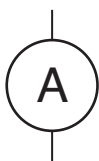

[2]

[Total: 7]

3 This question is about the radio **transmitter** in a mobile phone.

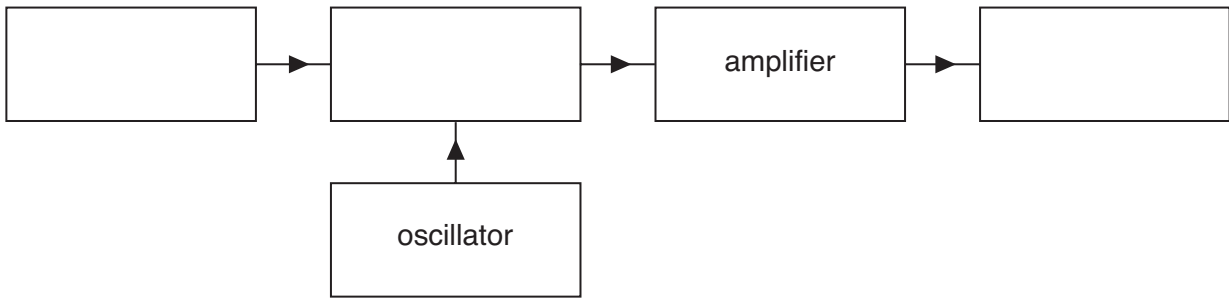

(a) Complete the block diagram for the **transmitter**. Use the words in this list.

- aerial microphone modulator**

[2]

(b) Use straight lines to link the **start** of each sentence with its correct end.

start	end
The aerial provides a signal for the modulator.
The oscillator provides a carrier for the modulator.
The amplifier sends out modulated radio waves.
The microphone increases the amplitude of a signal.

[3]

(c) Modern mobile phones use a **digital** format to send information.

(i) Suggest **one** advantage of sending information in a digital format.

.....
 [1]

(ii) Old mobile phones used an analogue format to send information. Which process **cannot** be used with an analogue format?

Put a **ring** around the correct answer.

- encryption reception transmission**

[1]

[Total: 7]

- 4 Sue uses the internet to communicate over large distances.

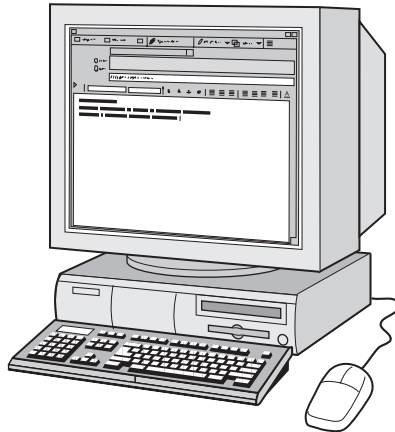

- (a) Complete each sentence by putting a **ring** around the correct word.

Sue types a message.

The keyboard is the **input** **output** **processor**.

The message is to go on the internet.

It must be **bar coded** **decoded** **encoded**.

The message arrives with no mistakes.

This means that the internet has a low **data rate** **error rate** **range**.

[3]

- (b) There have to be standard **protocols** for internet messaging to work.
Who decides these protocols?

Put a **ring** around the answer.

advertisers **amateurs** **governments**

[1]

- (c) The internet has increased the **quantity** of human communication.
Give an example of **another** electronic device which has increased the quantity of human communication.

..... [1]

[Total: 5]

BLANK PAGE

PLEASE DO NOT WRITE ON THIS PAGE

- 5 Anita worries about burglars. She uses a video screen to view pictures from **three** cameras placed around her house.



- (a) Complete this block diagram for her system.

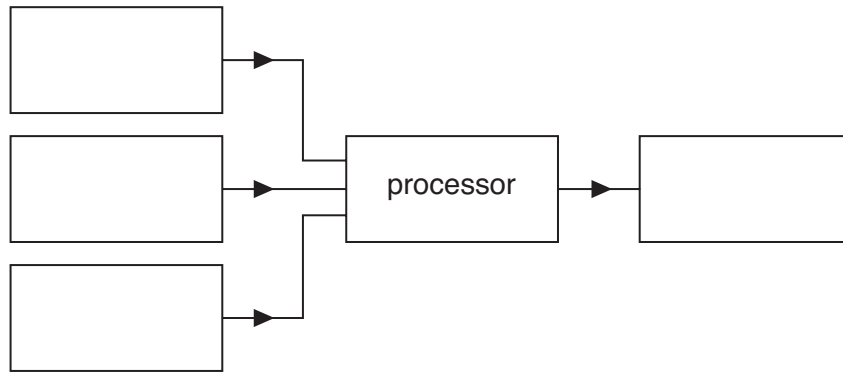

[1]

- (b) Complete the sentence.

Choose a word from this list.

current information light microwaves

The arrows in the diagram show the flow of from one block to another.

[1]

- (c) State one feature of a circuit diagram which makes it look different from a block diagram.

.....

[1]

(d) Here is some technical data for the video screen.

bits for each pixel	4
pixels per frame	65 536
frame refresh rate	32 per second

(i) Use the data to calculate the video bit rate for the cable leading to the screen.

video bit rate = bits per second [1]

(ii) Each row of the screen has 256 pixels.
How many bits of information are needed for each row of the screen?

information = bits [1]

[Total: 5]

6 An office uses copper wire to link its fax machines to each other.



This is because copper wire is cheap and easy to use.
Other communication systems use radio waves.

(a) Describe your own example of a different communication system that uses **radio waves** as the link.

.....
..... [1]

(b) Explain why radio waves are the best link for your example.

.....
.....
..... [2]

(c) Communication systems use different radio frequencies.
Put a ring around the frequency that best matches your example.

100 MHz 600 MHz 2 GHz 10 GHz [1]

(d) It is quite expensive to use radio waves as the link for a communication system.
Explain **another** disadvantage of using radio waves as the link.

.....
.....
.....
..... [2]

[Total: 6]

END OF QUESTION PAPER

11
BLANK PAGE

PLEASE DO NOT WRITE ON THIS PAGE

PLEASE DO NOT WRITE ON THIS PAGE



Copyright Information

OCR is committed to seeking permission to reproduce all third-party content that it uses in its assessment materials. OCR has attempted to identify and contact all copyright holders whose work is used in this paper. To avoid the issue of disclosure of answer-related information to candidates, all copyright acknowledgements are reproduced in the OCR Copyright Acknowledgements Booklet. This is produced for each series of examinations, is given to all schools that receive assessment material and is freely available to download from our public website (www.ocr.org.uk) after the live examination series.

If OCR has unwittingly failed to correctly acknowledge or clear any third-party content in this assessment material, OCR will be happy to correct its mistake at the earliest possible opportunity.

For queries or further information please contact the Copyright Team, First Floor, 9 Hills Road, Cambridge CB2 1GE.

OCR is part of the Cambridge Assessment Group; Cambridge Assessment is the brand name of University of Cambridge Local Examinations Syndicate (UCLES), which is itself a department of the University of Cambridge.