



H

Monday 21 May 2012 – Morning

**GCSE TWENTY FIRST CENTURY SCIENCE
PHYSICS A**

A332/02 Unit 2: Modules P4 P5 P6 (Higher Tier)

Candidates answer on the Question Paper.
A calculator may be used for this paper.

OCR supplied materials:
None

Other materials required:

- Pencil
- Ruler (cm/mm)

Duration: 40 minutes



Candidate forename		Candidate surname	
-----------------------	--	----------------------	--

Centre number							Candidate number				
---------------	--	--	--	--	--	--	------------------	--	--	--	--

INSTRUCTIONS TO CANDIDATES

- Write your name, centre number and candidate number in the boxes above. Please write clearly and in capital letters.
- Use black ink. HB pencil may be used for graphs and diagrams only.
- Answer **all** the questions.
- Read each question carefully. Make sure you know what you have to do before starting your answer.
- Write your answer to each question in the space provided. Additional paper may be used if necessary but you must clearly show your candidate number, centre number and question number(s).
- Do **not** write in the bar codes.

INFORMATION FOR CANDIDATES

- The number of marks is given in brackets [] at the end of each question or part question.
- The total number of marks for this paper is **42**.
- A list of physics equations is printed on page two.
- This document consists of **16** pages. Any blank pages are indicated.

TWENTY FIRST CENTURY SCIENCE EQUATIONS**Useful Relationships****Explaining Motion**

$$\text{speed} = \frac{\text{distance travelled}}{\text{time taken}}$$

$$\text{momentum} = \text{mass} \times \text{velocity}$$

$$\text{change of momentum} = \text{resultant force} \times \text{time for which it acts}$$

$$\text{work done by a force} = \text{force} \times \text{distance moved in the direction of the force}$$

$$\text{change in energy} = \text{work done}$$

$$\text{change in GPE} = \text{weight} \times \text{vertical height difference}$$

$$\text{kinetic energy} = \frac{1}{2} \times \text{mass} \times [\text{velocity}]^2$$

Electric Circuits

$$\text{resistance} = \frac{\text{voltage}}{\text{current}}$$

$$\frac{\text{voltage across primary coil}}{\text{voltage across secondary coil}} = \frac{\text{number of turns in primary coil}}{\text{number of turns in secondary coil}}$$

$$\text{energy transferred} = \text{power} \times \text{time}$$

$$\text{power} = \text{potential difference} \times \text{current}$$

$$\text{efficiency} = \frac{\text{energy usefully transferred}}{\text{total energy supplied}} \times 100\%$$

The Wave Model of Radiation

$$\text{wave speed} = \text{frequency} \times \text{wavelength}$$

Answer **all** the questions.

- 1 A car is travelling along a motorway.

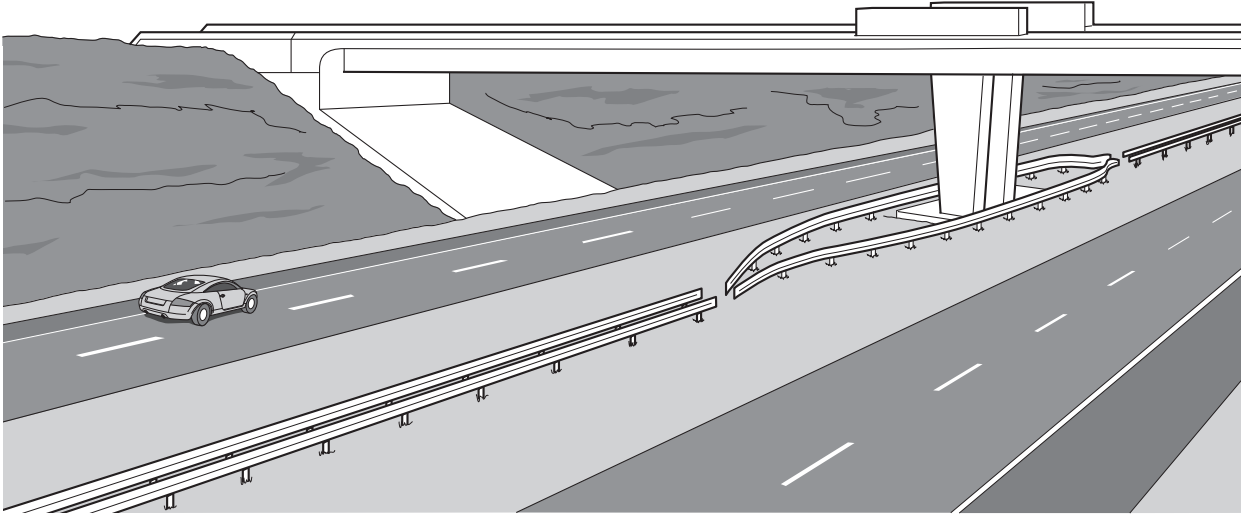

- (a) (i) The car takes 60 s to travel 1.2 km.
What is its speed?

Put a **ring** around the correct answer.

0.02 m/s **1.2 m/s** **20 m/s** **72 m/s** **1200 m/s**

[1]

- (ii) How should the speed you found in part (a)(i) be described, and why?

Draw **one** line to link the correct **description** to the correct **explanation**.

description

average speed

instantaneous speed

velocity

explanation

It is the speed in a particular direction.

It is the speed shown at a particular time by the car's speedometer.

It takes into account the fact that the car will speed up and slow down as it travels.

[1]

- (b) (i) The graph below is a distance-time graph for a car travelling along a straight track.

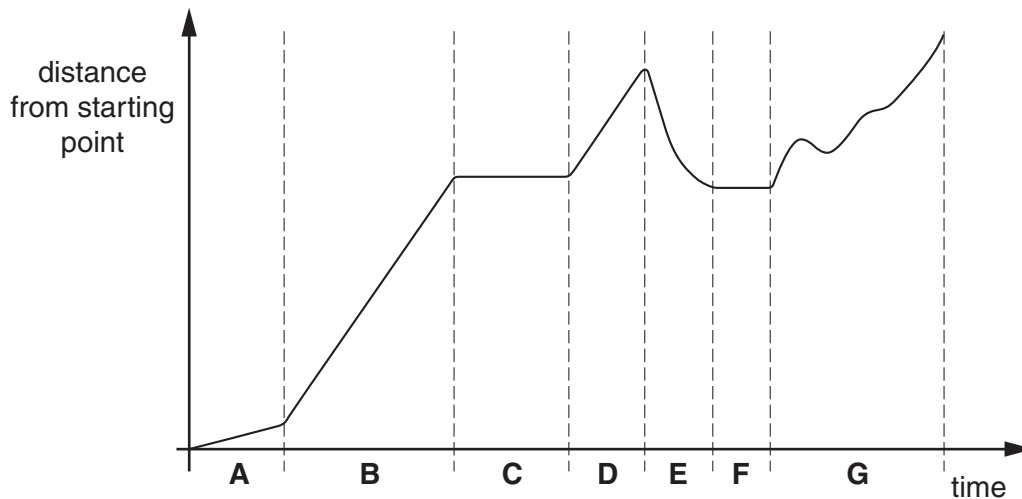

Some of the following statements about the **whole journey** are true and some are false. Put a tick (✓) in the correct box next to each statement to show whether it is **true** or **false**.

	true	false
The car's slowest speed was in section A .	<input type="checkbox"/>	<input type="checkbox"/>
The car was always moving forwards.	<input type="checkbox"/>	<input type="checkbox"/>
The car was going at the same speed in sections B and D .	<input type="checkbox"/>	<input type="checkbox"/>
The velocity of the car varied the most within section G .	<input type="checkbox"/>	<input type="checkbox"/>

[2]

- (ii) On the axes below, sketch a velocity-time graph for sections **C** and **D**. You do not need to include any numbers.

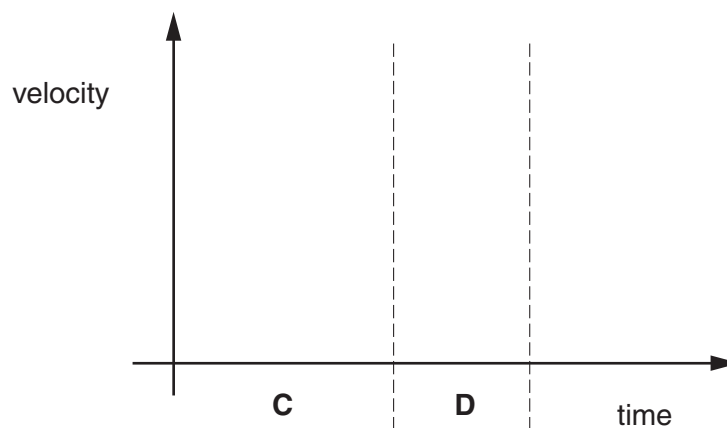

[1]

[Total: 5]

- 2 The picture shows a toy plane.
The plane has a motor that pushes it along.
Two of the forces that act on the plane are shown.

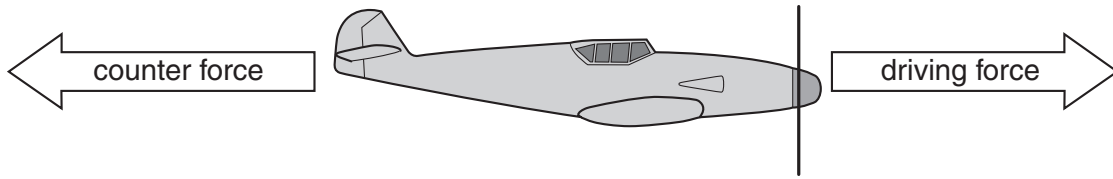

Here is some information about the plane at one particular time.

mass	0.5 kg
speed	8 m/s
driving force	10 N
counter force	3 N

- (a) Use the information to calculate the momentum of the plane at this time.

momentum = unit [2]

- (b) Use the information to explain why the momentum of the plane increases over the next few seconds.

.....

.....

.....

..... [2]

[Total: 4]

- 3 There are many sports that take place in the Olympics. All of the sports involve forces and energy.

(a) One of the events in gymnastics is the rings.



The forces below are involved in this gymnastic event. When one object exerts a force on another, it always experiences a force in return. From the forces below, identify **two** interaction pairs. Draw a line between the two forces that make each interaction pair. Draw **two** lines only.

the weight
of the
gymnast

friction
between the
gymnast's
hands and
the rings

the pull
from the
gymnast on
the Earth

the pull of
the gymnast
on the rings

the force
from the
rings acting
on the
gymnast

air
resistance
as the
gymnast
moves

- (b) A weightlifter lifts a barbell above her head.



- (i) The barbell is lifted to a height of 2.5 m above the ground. It gains 3750 J of gravitational potential energy.

What is the weight of the barbell?

Put a **ring** around the correct answer.

0.00066 N

1500 N

3747.5 N

3752.5 N

9375 N

[1]



- (ii) Another weightlifter lifts a barbell with a mass of 100 kg. The barbell gains 2000 J of gravitational potential energy. She then drops the barbell.

Calculate the maximum speed that the barbell could reach just before hitting the ground.

maximum speed = m/s [2]

[Total: 5]

4 Rob is trying to choose between two different types of walkie talkie.

<p>digital walkie talkie</p>  <p>£199</p> <p>Great signal over long distances! Amazing signal quality!</p>	<p>analogue walkie talkie</p>  <p>£70</p> <p>Cheap and easy to use! Perfect for short distances!</p>
--	---

(a) Before radio signals are sent, they have to be modulated. Modulation can change either the amplitude or the frequency of a carrier wave. Draw three straight lines to join each **description** to the **signal** that it describes.

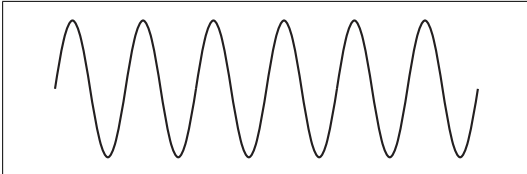
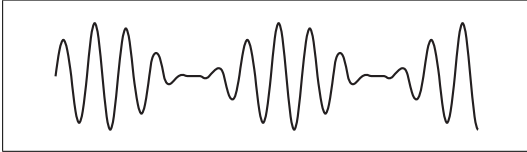
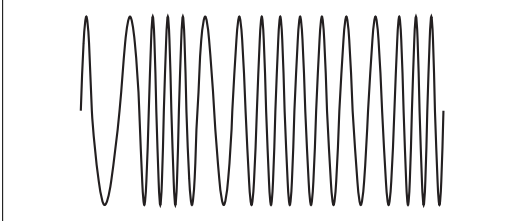
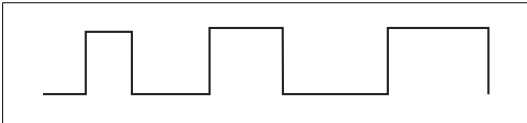
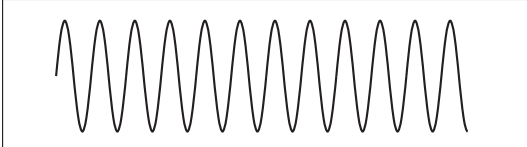
description	signal
digital signal	
analogue signal with amplitude modulation	
analogue signal with frequency modulation	
digital signal	
analogue signal with amplitude modulation	

[2]

- (b) Which three of the following statements, when taken together, can be used to explain why a digital walkie talkie can be used over longer distances than an analogue walkie talkie? Put ticks (✓) in the boxes next to the **three** correct answers.

As signals travel, their amplitudes become smaller and they pick up noise.

Digital signals travel at the speed of light.

When a signal is amplified, noise is also amplified.

Radio waves are not strongly absorbed by the atmosphere.

Analogue signals vary continuously.

The information in digital signals can usually be recognised despite some noise picked up.

The job of the receiver is to reproduce the original sound from a signal.

[2]

- (c) The two walkie talkies both use radio waves with a wavelength of 1.5 m. Which calculation shows how the frequency in hertz of the wave can be calculated?

Put a (ring) around the correct answer.

$$\frac{3 \times 10^2}{1.5}$$

$$\frac{3 \times 10^8}{1.5}$$

$$1.5 \times 3 \times 10^2$$

$$1.5 \times 3 \times 10^8$$

$$\frac{1.5}{3 \times 10^2}$$

$$\frac{1.5}{3 \times 10^8}$$

[1]

[Total: 5]

5 Millie is taking a picture using a camera with a flash.



(a) The diagram shows one path of light through the camera.

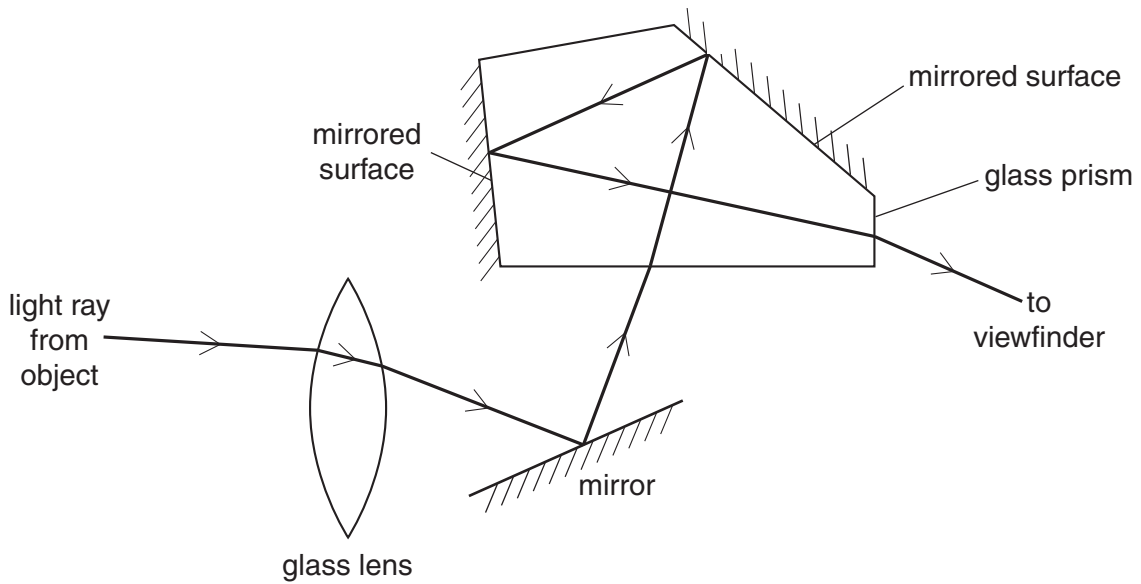

(i) When light travels, it can be **diffracted**, **reflected** or **refracted**, or undergo **total internal reflection**.

Only two of these effects happen along the light path in the camera.

Put rings around the **two** effects that are shown on the diagram.

diffraction reflection refraction total internal reflection

[1]

(ii) As light travels into and out of glass, its speed changes.

Complete the following sentences by putting a **(ring)** around the correct choice in each sentence.

When light slows down, the wavelength **increases / stays the same / decreases.**

When light slows down, the frequency **increases / stays the same / decreases.**

[1]

(b) Millie takes a picture of a dog with her camera. She uses the camera flash.

(i) Which two of the following would increase the **intensity** of the light reaching the dog? Put ticks (✓) in the boxes next to the **two** correct statements.

- more photons hitting the dog per second
- increasing the distance to the dog
- changing the speed of the light
- using photons of lower energy
- using photons of shorter wavelength
- using photons of lower frequency

[2]

(ii) Light does **not** diffract noticeably when it enters the camera through the aperture (opening). Explain why.

.....

.....

.....

..... [2]

[Total: 6]

6 A long spring can be used to demonstrate different types of wave.

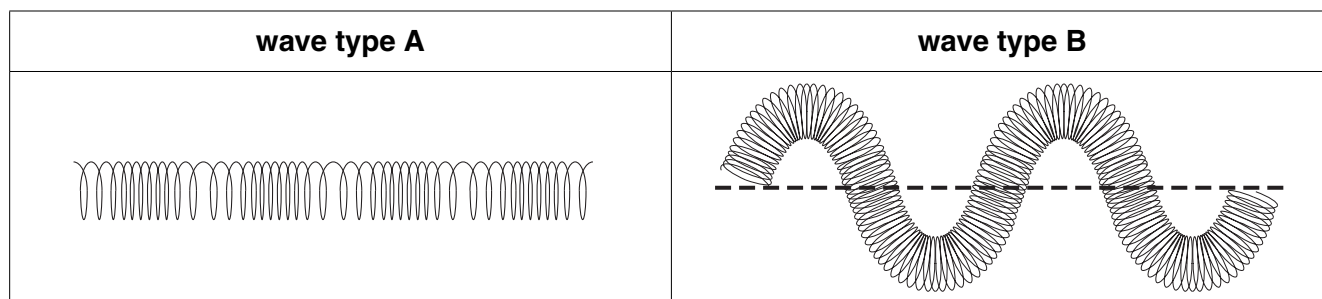

(a) Which type of wave is shown in each of the diagrams above?

wave type A

wave type B

[1]

(b) (i) Which of the following describes the **wavelength** of wave type B?
Put a tick (✓) in the box next to the correct answer.

- the distance from one end of the spring to the other end
- the distance from the wave crest to the wave trough of the spring
- the thickness of the spring
- the distance from the first wave crest to the second wave crest
- the distance from a wave crest to the dotted line

[1]

(ii) Which of the following describes the **amplitude** of wave type B?
Put a tick (✓) in the box next to the correct answer.

- the distance from one end of the spring to the other end
- the distance from the wave crest to the wave trough of the spring
- the thickness of the spring
- the distance from the first wave crest to the second wave crest
- the distance from a wave crest to the dotted line

[1]

(c) To make wave type A, one end of the spring is moved 4 times every second.
The wavelength is 50 cm.
How fast is the wave travelling?
Put a (ring) around the correct answer.

- 0.5 m/s
2 m/s
4 m/s
8 m/s
200 m/s

[1]

[Total: 4]

- 7 George charges two identical plastic rods by rubbing them with a cloth. He hangs the rods close to each other. The rods move away from each other.

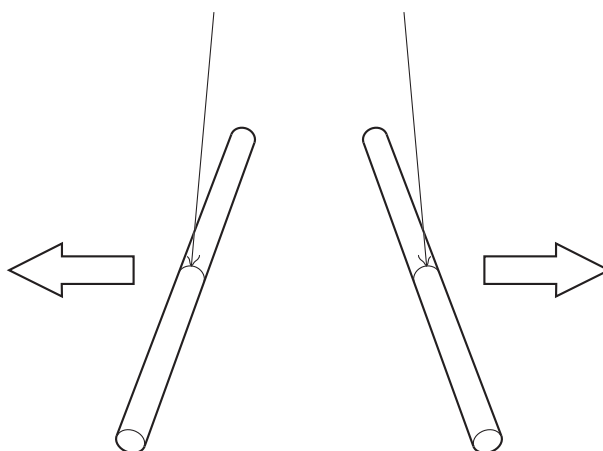

- (a) Explain why the rods move away from each other. Include in your answer
- what happens when the rods are rubbed with the cloth
 - why the rods move away from each other.

.....

.....

.....

.....

..... [3]

- (b) George repeats the experiment with metal rods. The rods do not move. Join two boxes to make a sentence that helps to explain why the rods do not move. You should draw **one** straight line.

Metal rods contain lots of charges...	...which can not move.
Metal rods contain few charges...	...which are free to move.
Metal rods contain no charges...	...which move only when connected to a battery.

[1]

[Total: 4]

8 Ella buys a new electric heater.

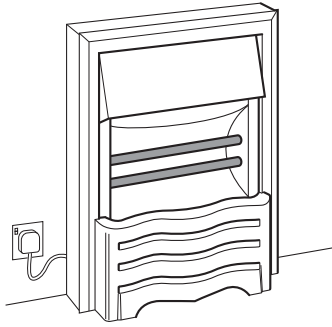

The bars in the heater are resistors.
The circuit for the heater can be represented in this way.

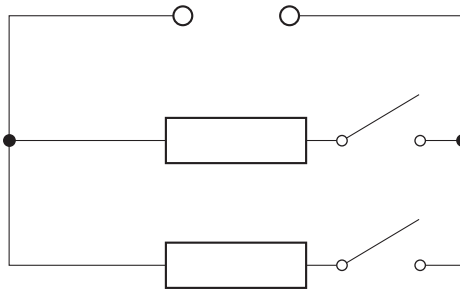

(a) Ella plugs the heater into the mains electricity supply.
When both bars are switched on, the total resistance is $23\ \Omega$.

What current is drawn from the mains?

Show your working.

current = amps [2]

(b) Ella switches off one of the bars.

The table shows four quantities which may change as Ella switches off the bar.

For each quantity in the table, put a tick (✓) in the correct box to show whether it will **increase**, **decrease** or **stay the same**.

quantity	increase	decrease	stay the same
the number of paths for the charges			
the potential difference across the hot bar			
the current drawn from the mains			
the total resistance of the circuit			

[2]

(c) Ella is worried that using the heater is going to cost her a lot of money.

How long could she use the heater for if she only spends £2.30 on the electricity?

The cost for one kilowatt-hour is 20p.

The heater has an average power of 2300 watts.

answer = hours [2]

[Total: 6]

Please turn over for Question 9

9 Vikram's laptop computer has a transformer in its charging cable.

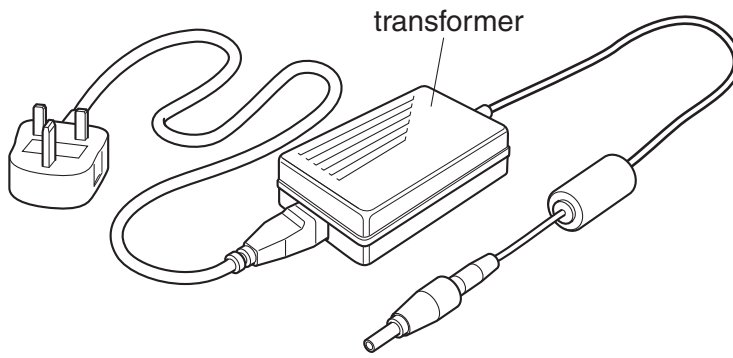

The diagram below shows the construction of the transformer.

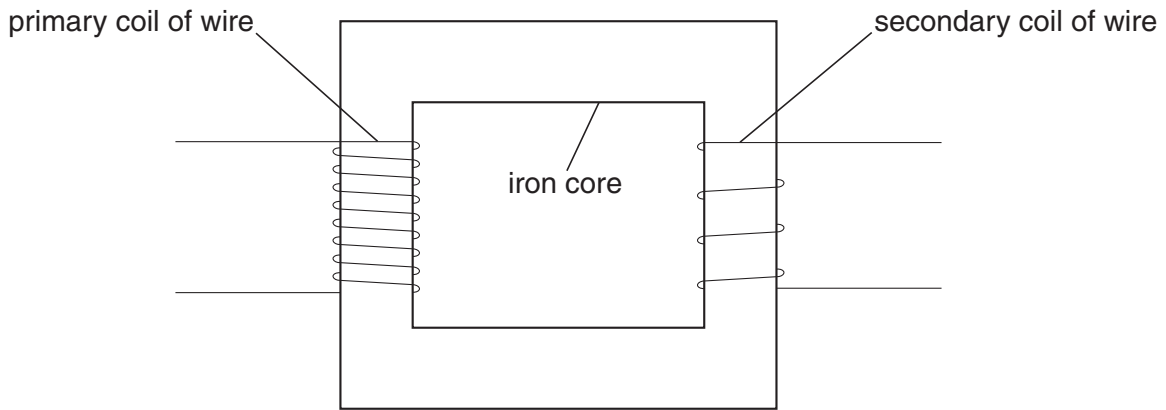

Explain how a transformer produces a voltage across the secondary coil.

.....

.....

.....

.....

..... [3]

[Total: 3]

END OF QUESTION PAPER



Copyright Information

OCR is committed to seeking permission to reproduce all third-party content that it uses in its assessment materials. OCR has attempted to identify and contact all copyright holders whose work is used in this paper. To avoid the issue of disclosure of answer-related information to candidates, all copyright acknowledgements are reproduced in the OCR Copyright Acknowledgements Booklet. This is produced for each series of examinations and is freely available to download from our public website (www.ocr.org.uk) after the live examination series.

If OCR has unwittingly failed to correctly acknowledge or clear any third-party content in this assessment material, OCR will be happy to correct its mistake at the earliest possible opportunity.

For queries or further information please contact the Copyright Team, First Floor, 9 Hills Road, Cambridge CB2 1GE.

OCR is part of the Cambridge Assessment Group; Cambridge Assessment is the brand name of University of Cambridge Local Examinations Syndicate (UCLES), which is itself a department of the University of Cambridge.