



Rewarding Learning

General Certificate of Secondary Education
2016–2017

Centre Number

--	--	--	--	--

Candidate Number

--	--	--	--	--

Science: Single Award

Unit 3 (Physics)
Foundation Tier

MV18

[GSS31]

FRIDAY 11 NOVEMBER 2016, AFTERNOON

Time

1 hour, plus your additional time allowance.

Instructions to Candidates

Write your Centre Number and Candidate Number in the spaces provided at the top of this page.

Write your answers in the spaces provided in this question paper.

Answer **all nine** questions.

Information for Candidates

The total mark for this paper is 60.

Figures in brackets printed at the end of each question indicate the marks awarded to each question or part question.

Quality of written communication will be assessed in Question **9(a)**.

1 The diagram below shows the Sun and its eight planets.

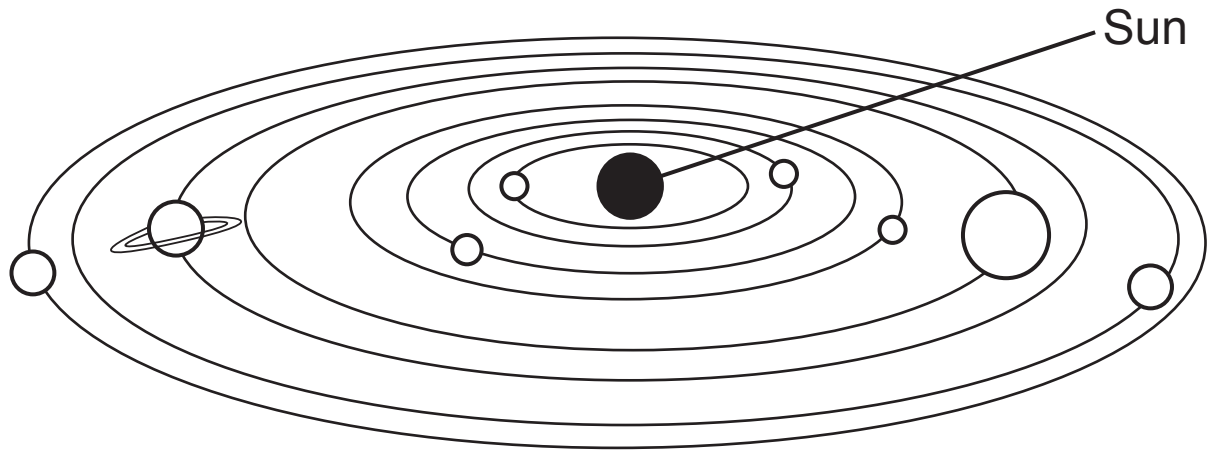

(a) What name is given to this model of the Solar System?

Circle the correct answer. [1 mark]

geocentric

heliocentric

concentric

(b) Complete the following sentences. [2 marks]

Choose from:

moon

galaxy

star

A huge collection of stars is called a

_____ .

An object that orbits a planet is called a

_____ .

(c) Place a tick (✓) beside the statement that best describes the movement of most galaxies. [1 mark]

They are moving closer to each other

They are moving but staying the same distance apart

They are moving away from each other

(d) The diagram below shows the first three planets in our Solar System.

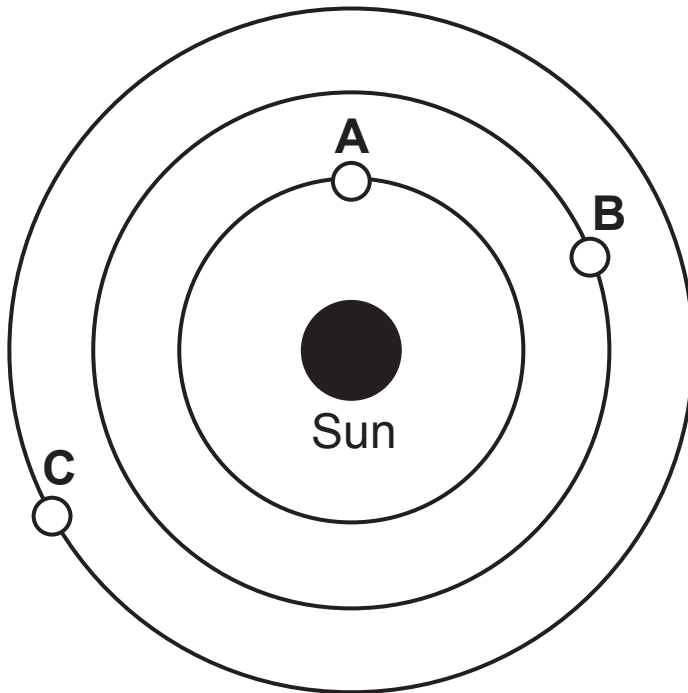

(i) Name the planet labelled **B**. [1 mark]

Answer _____

(ii) Which planet (**A**, **B** or **C**) will take the shortest time to orbit the Sun? [1 mark]

Answer _____

- 2 (a) The information below gives some of the stages in the production of fossil fuels but they are not in the correct order.

A	buried by sediments
B	high pressure and heat
C	the remains of dead plants and animals

- (i) Using the letters **A**, **B**, and **C** put the stages in the correct order. [1 mark]



- (ii) Complete the following sentence. [1 mark]

Choose from:

tens

hundreds

millions

It takes _____ of years to produce fossil fuels.

(b) The diagram below shows how a small town used 3200 litres of oil.

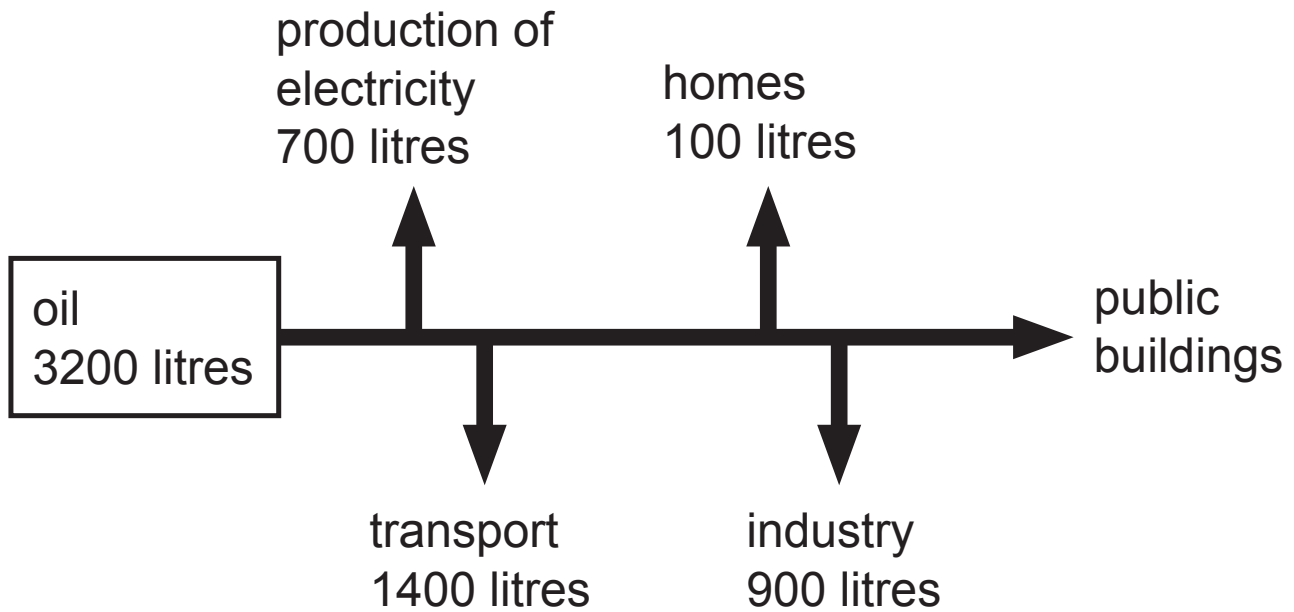

Calculate the number of litres of oil that were used in **public buildings**. [2 marks]

(Show your working out.)

Answer _____ litres

(c) The flow chart below represents the parts found within an oil-burning power station.

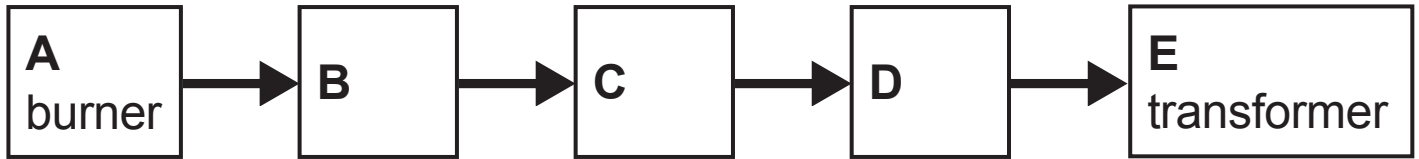

Name parts **B**, **C** and **D** shown in the diagram.
[2 marks]

Choose from:

generator

boiler

turbine

B _____

C _____

D _____

- 3 (a) Adam investigated how height affects the stopping distance of a trolley using the apparatus shown below.

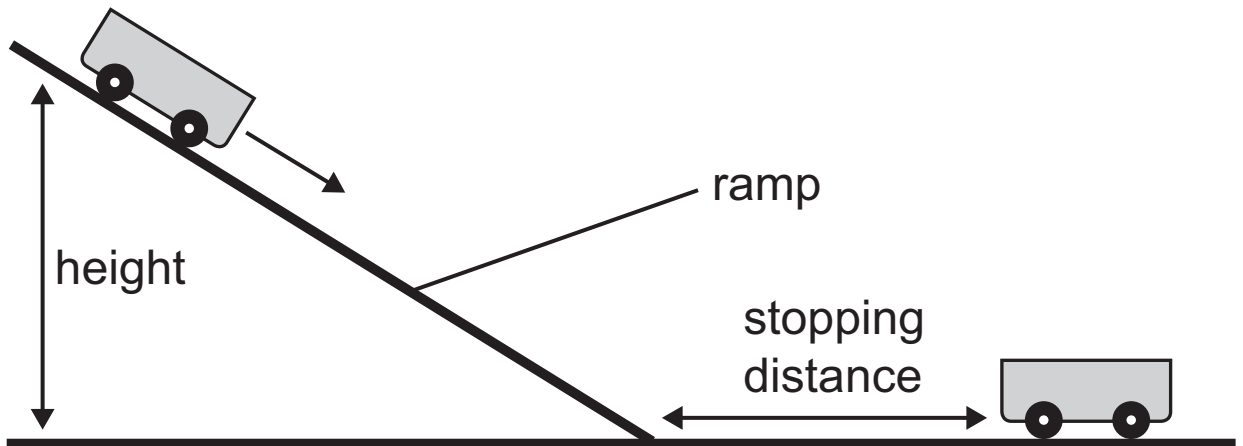

He changed the height of the ramp and measured how far the trolley travelled from the end of the ramp.

- (i) Give **one** thing Adam might have done to make the results more reliable. [1 mark]

Circle the correct answer.

used the same trolley

repeated and averaged the results

used the same ramp

- (ii) Name the force which opposes the movement of the trolley. [1 mark]

(iii) Adam's results are shown in the table below.

Height of ramp/cm	Stopping distance/cm
5	0
10	5
15	10
20	15

On the grid below draw a **line graph** of Adam's results. [3 marks]

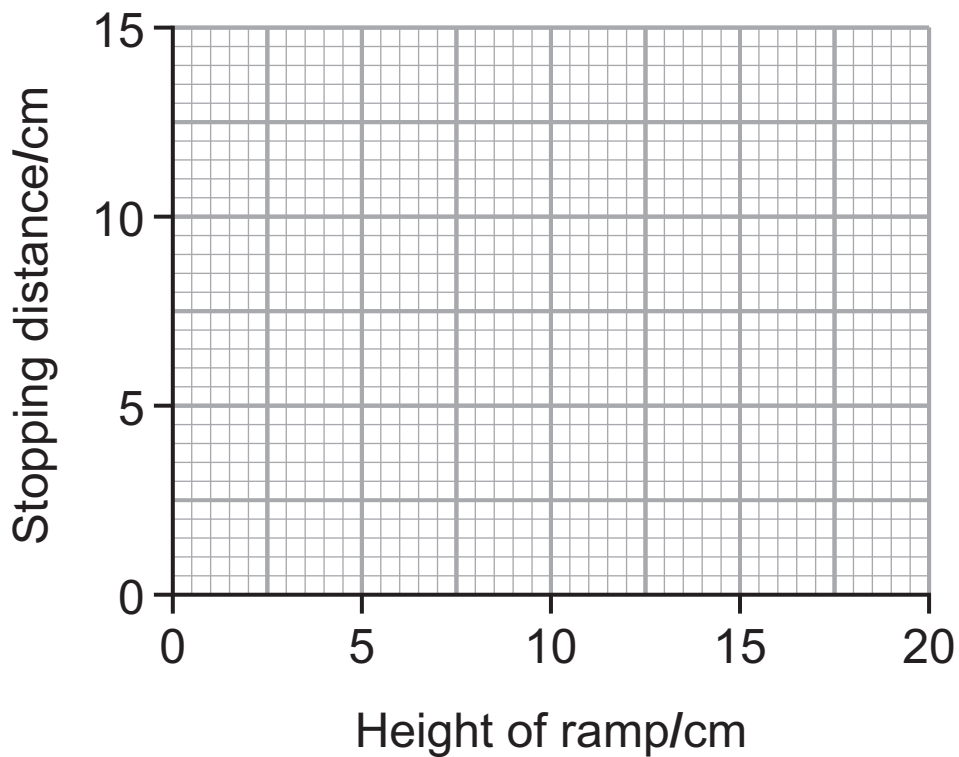

(b) Adam set the height of the ramp at 20 cm to investigate if adding mass affects the stopping distance of the trolley.

His results are shown below.

Mass added to trolley/g	Stopping distance/cm
0	15
100	18
200	21
300	25
400	30

Complete the sentence below to give the trend shown by these results. [1 mark]

As the mass added to the trolley _____

BLANK PAGE

(Questions continue overleaf)

- 4 James set up the circuit below to measure the voltage produced by two cells (batteries) and the current through two bulbs. However it contains some mistakes.

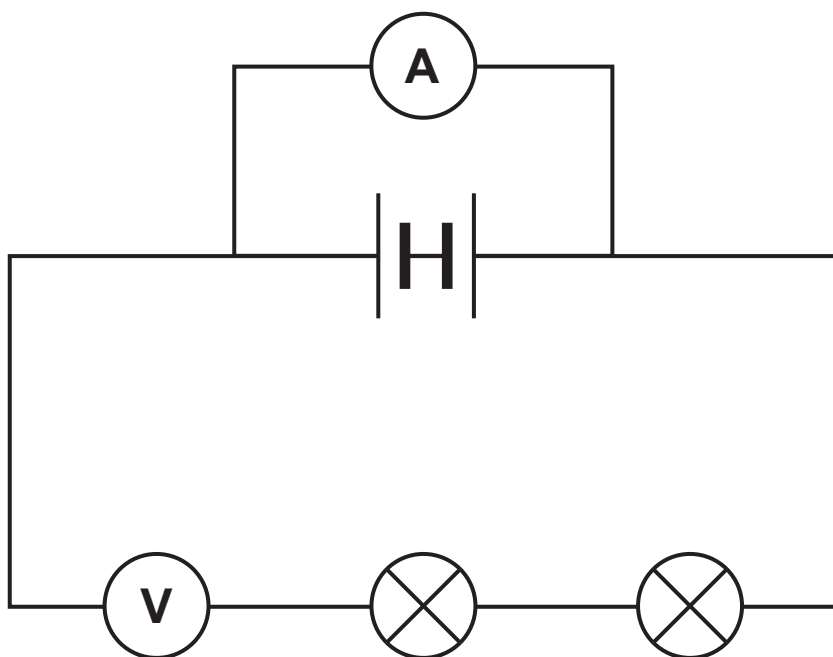

- (a) Using the same electrical symbols, complete the diagram below to show the correct circuit. [2 marks]

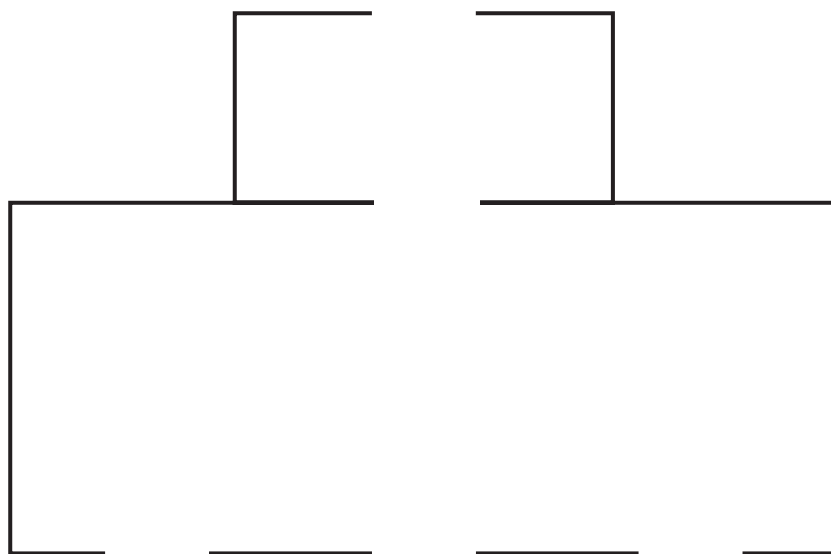

The circuit diagram below shows how the lights of a model car are controlled.

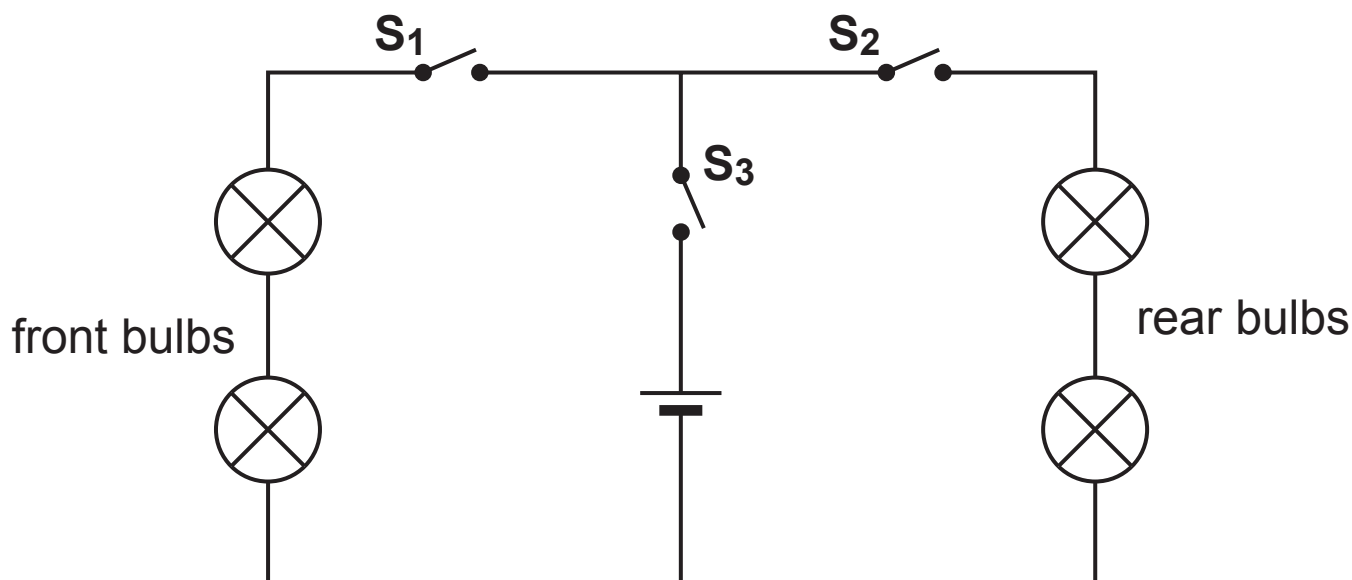

(b) Which switches (S_1 , S_2 or S_3) should be closed:

1. to **only** turn on the front bulbs? [1 mark]

Answer _____

2. to turn on **all** the bulbs? [1 mark]

Answer _____

- 5 (a) The diagram below shows how 1000J of energy is changed by a television.

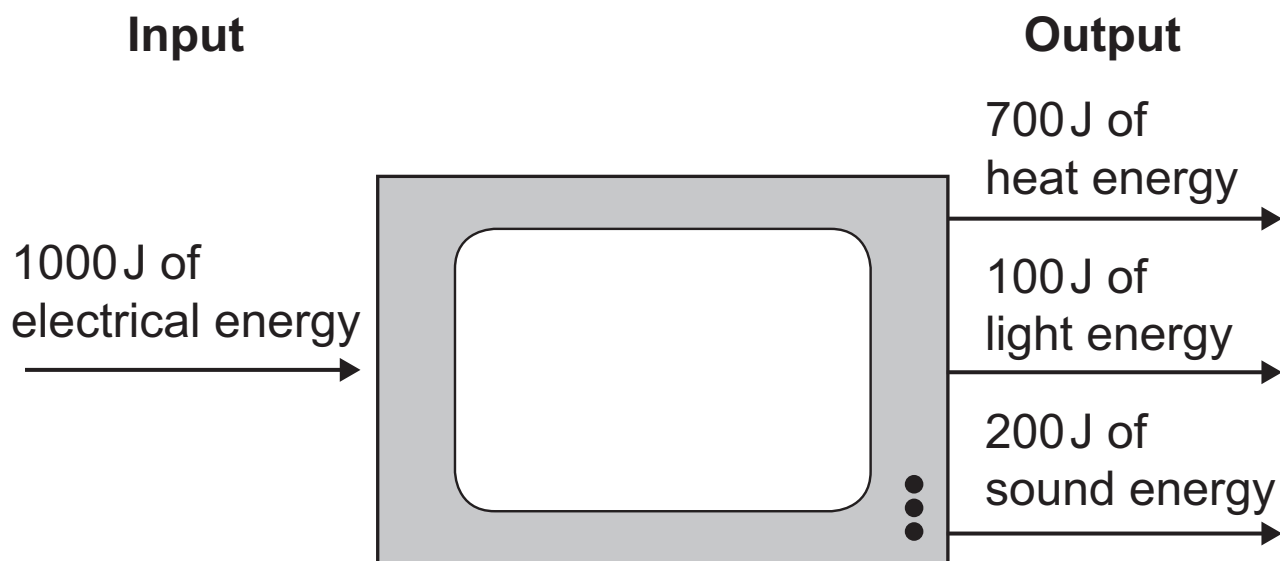

- (i) Only some output energy coming from the television is wanted.
This is useful output energy.
Calculate the useful output energy. [1 mark]

Answer _____ J

- (ii) The efficiency of this television is low.
Suggest **one** reason why someone would want a more efficient television. [1 mark]

(b) Complete the following sentences. [1 mark]

The law of conservation of energy states that energy can not be _____ or _____ .

It can only be changed from one form to another.

6 (a) Shown below is a distance–time graph for a van.

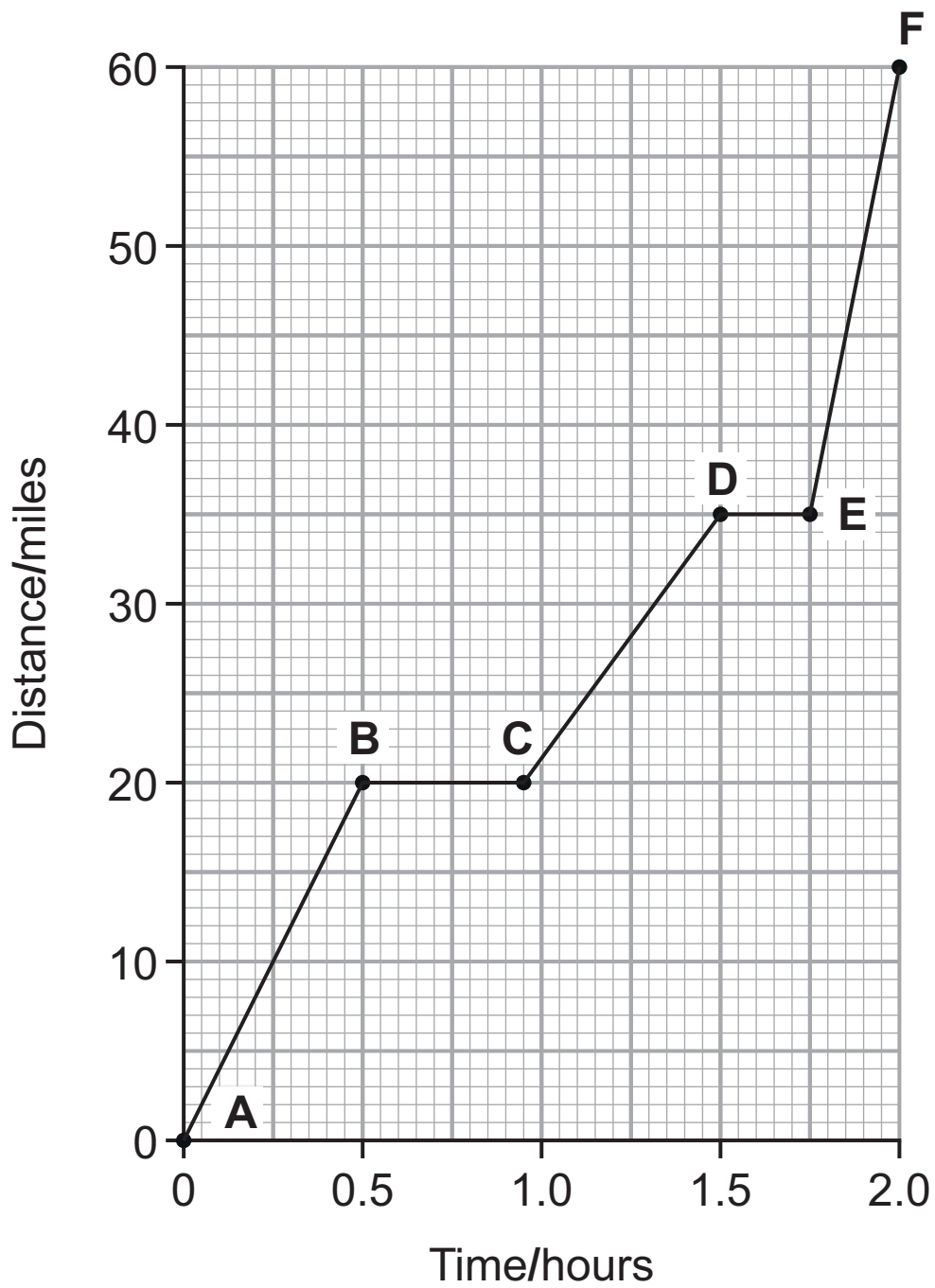

(i) Describe the motion of the van from **D** to **E**.

Circle the correct answer. [1 mark]

stopped

steady speed

slowing down

(ii) Between which two points is this van travelling the fastest? [1 mark]

Choose from:

A–B

C–D

E–F

Answer _____

(iii) Use the equation:

$$\text{average speed} = \frac{\text{distance}}{\text{time}}$$

to calculate the average speed of the van
between **A** and **F**. [2 marks]

(Show your working out.)

Answer _____ mph

The table below shows the results for a different journey by the van.

Time/hours	Distance/miles
0	0
0.5	15
1.0	30
1.5	45
2.0	60

- (b) Over the two hours of this journey, is the average speed more than, less than, or the same as the previous journey from **A** to **F** on the graph on page 16?
[1 mark]
-

(c) The table below shows the thinking and braking distances at 20mph and 50mph for a car on different road conditions.

Speed/ mph	Road conditions	Thinking distance/ m	Braking distance/ m
20	dry	6	6
	snow	6	24
	ice	6	60
50	dry	15	38
	snow	15	152
	ice	15	395

(i) What effect, if any, does speed have on the thinking distance? [1 mark]

(ii) What effect, if any, do road conditions have on the thinking distance? [1 mark]

(iii) Calculate the stopping distance for a car travelling at 20mph on a road covered with ice. [1 mark]

Answer _____ m

(d) The photograph below shows a crash test dummy after a collision.



State **two** features shown in the photograph which will reduce the risk to drivers in an accident. [2 marks]

1. _____
2. _____

- 7 (a) The table below shows the lowest and highest frequencies that some sea animals can hear.

Sea animal	Lowest frequency/ Hz	Highest frequency/ Hz
Porpoise	75	150 000
Beluga whale	1000	123 000
Dolphin	40 000	100 000
Seal	300	56 000

- (i) Many sea animals can hear ultrasound. What is meant by the term 'ultrasound'? [2 marks]

- (ii) Name the sea animal which can **only** hear ultrasound. [1 mark]

Answer _____

- (iii) Name the sea animal which can hear the greatest range of frequencies. [1 mark]

Answer _____

(b) The diagram below shows a dolphin using ultrasound to hunt fish.

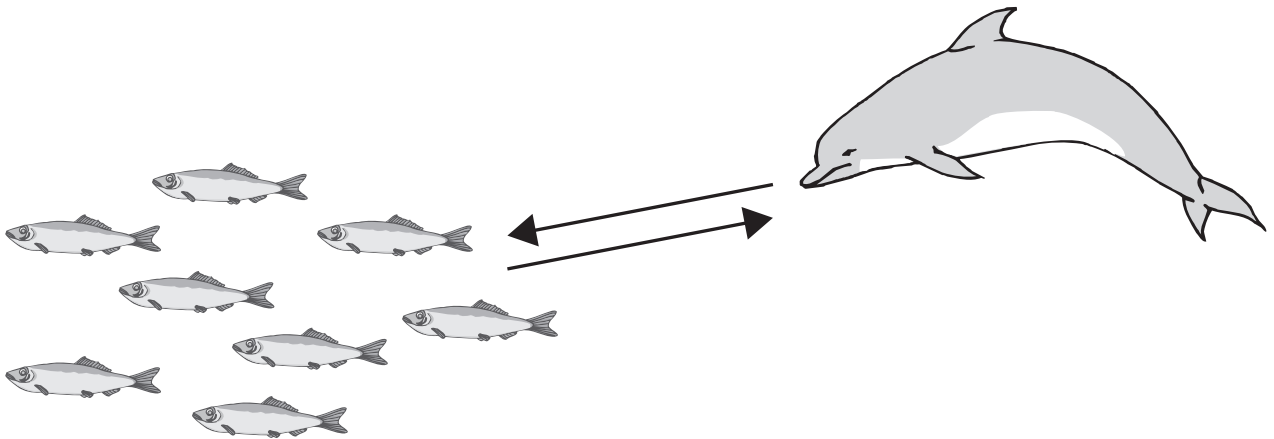

The dolphin sends out an ultrasound pulse and the echo returns 0.04 seconds later. Ultrasound travels at 1500 m/s in water.

Use the equation:

$$\text{distance} = \text{speed} \times \text{time}$$

to calculate the distance between the dolphin and the fish.
[3 marks]

(Show your working out.)

Answer _____ m

- 8 The apparatus below was used to investigate the type(s) of radiation emitted from a source.

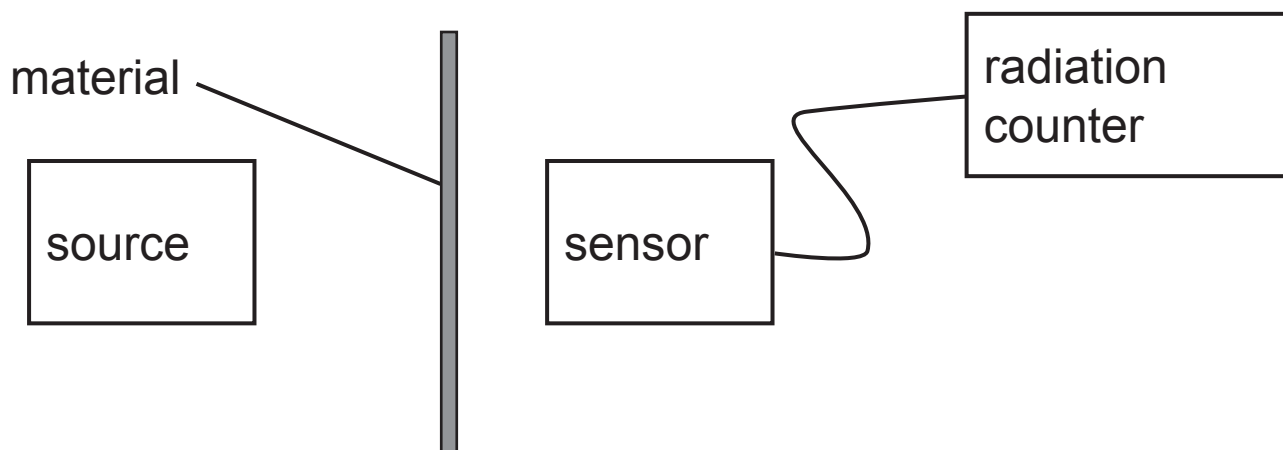

The table below shows the results obtained when different materials were used.

Material	Radiation/cpm
None	1000
1 mm paper	800
5 mm aluminium	800
30 mm lead	15

- (a) Name the **two** types of radiation produced by this source. [3 marks]
Explain your answer.

- (b) Radioactive tracers are used to examine organs inside the body. The tracer is put into the patient's body and followed by sensors outside the body.

The table below gives information about three isotopes of iodine that could be used as tracers.

Isotope	Radiation emitted	Half-life
Iodine-128	beta	25 minutes
Iodine-129	beta and gamma	25 000 000 years
Iodine-131	beta and gamma	8 days

- (i) Explain fully what is meant by the term 'half-life'.
[2 marks]

- (ii) Which isotope of iodine would be the best to use as a radioactive tracer? Explain your answer fully.

Isotope [1 mark]

Explanation [2 marks]

(iii) Explain fully why some nuclei are radioactive.
[2 marks]

BLANK PAGE

(Questions continue overleaf)

9 (a) The diagram below shows a hydroelectric power station.

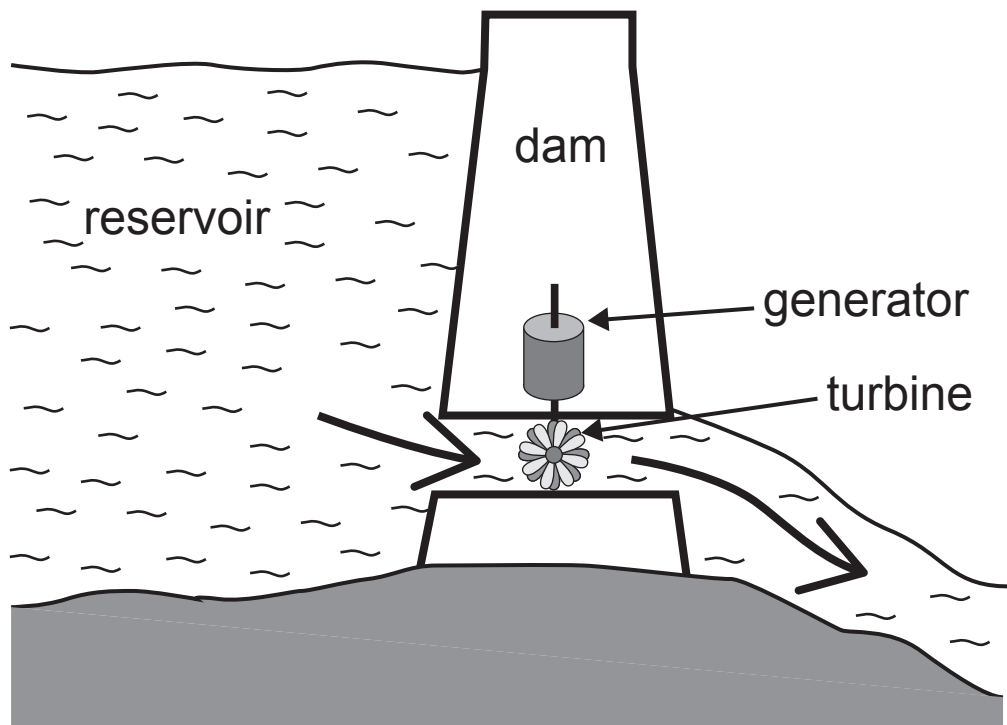

Explain how this power station produces electricity.
[6 marks]

Your answer should include the **advantages** and **disadvantages** of using hydroelectric power compared to fossil fuels.

Solar cells can also be used to produce electricity.
 The graph below shows the amount of electricity produced by a solar cell over a 24 hour period in summer.

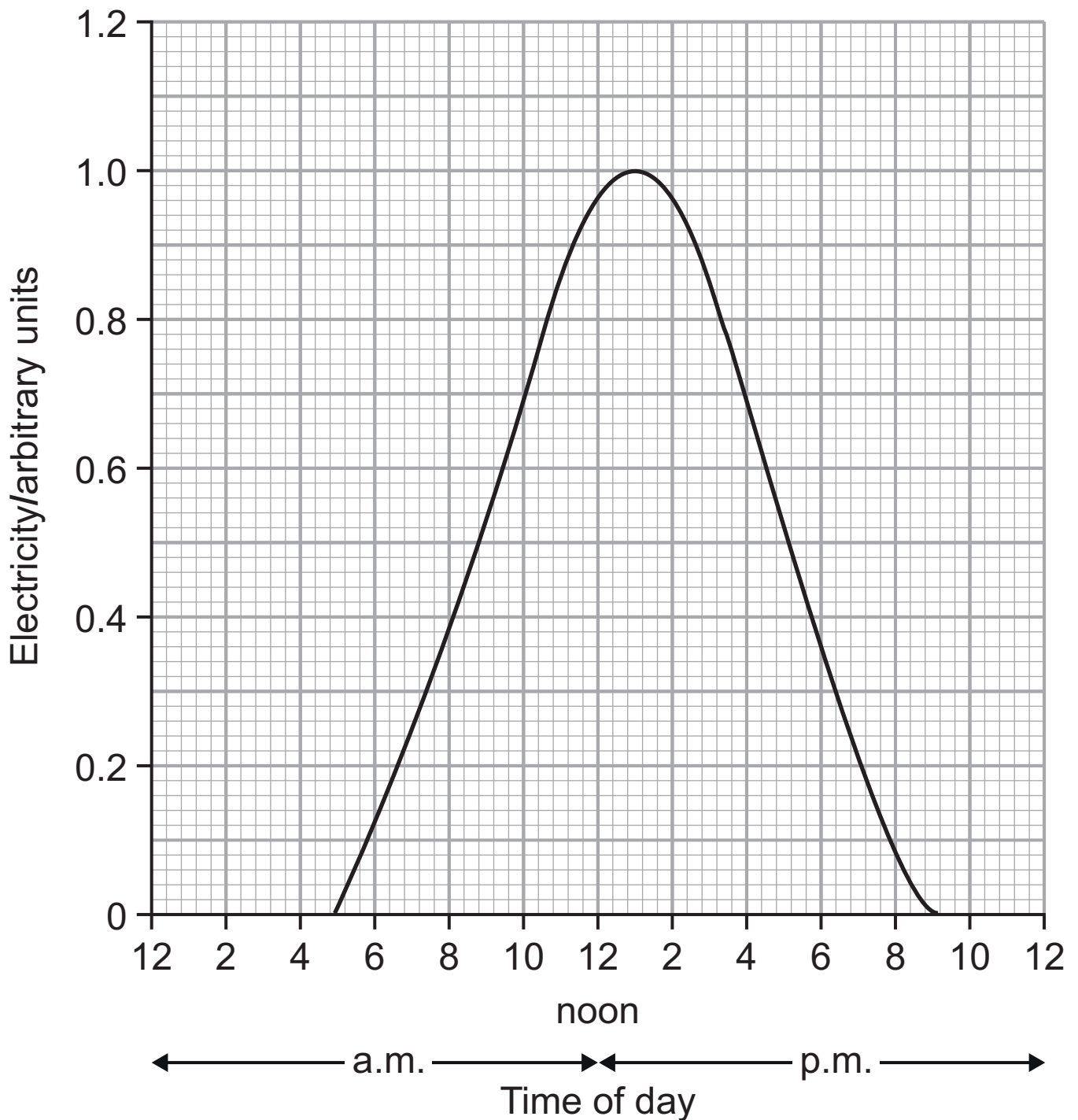

(b) On the same axes draw the curve you would expect for a 24 hour period in winter. [2 marks]

THIS IS THE END OF THE QUESTION PAPER

SOURCES

Q1.....Source: Principal Examiner
Q1(d)Source: Principal Examiner
Q3(a)Source: Principal Examiner
Q4Source: Principal Examiner
Q6(d)© Jim West / Science Photo Library
Q7(b)Source: Principal Examiner
Q9(a)Source: Principal Examiner

For Examiner's use only	
Question Number	Marks
1	
2	
3	
4	
5	
6	
7	
8	
9	

Total Marks	
--------------------	--

Permission to reproduce all copyright material has been applied for.
In some cases, efforts to contact copyright holders may have been unsuccessful and CCEA will be happy to rectify any omissions of acknowledgement in future if notified.