



General Certificate of Secondary Education  
2015–2016

Centre Number

--	--	--	--	--

Candidate Number

--	--	--	--	--

# Science: Single Award

Unit 3 (Physics)  
Higher Tier

[GSS32]

FRIDAY 26 FEBRUARY 2016, MORNING



## TIME

1 hour 15 minutes.

## INSTRUCTIONS TO CANDIDATES

Write your Centre Number and Candidate Number in the spaces provided at the top of this page.

Write your answers in the spaces provided in this question paper.  
Answer **all nine** questions.

## INFORMATION FOR CANDIDATES

The total mark for this paper is 75.

Figures in brackets printed down the right-hand side of pages indicate the marks awarded to each question or part question.

Quality of written communication will be assessed in Questions **3** and **8(c)**.

For Examiner's use only	
Question Number	Marks
1	
2	
3	
4	
5	
6	
7	
8	
9	

<b>Total Marks</b>	
--------------------	--

1 (a) Describe fully how fossil fuels were formed.

---

---

---

---

---

[3]

(b) Shown below are some parts of a fossil fuel power station.

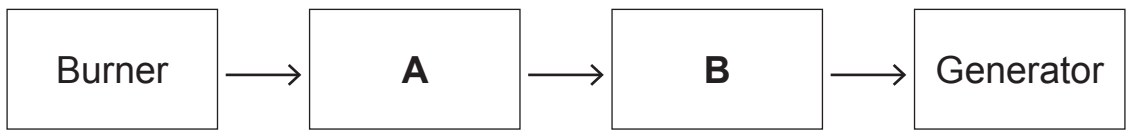

(i) Name the parts **A** and **B** shown in the diagram above.

**A** \_\_\_\_\_

**B** \_\_\_\_\_

[2]

(ii) Explain fully how a generator produces electricity.

---

---

---

[2]

Examiner Only	
Marks	Remark

(c) The graph below shows the percentage of electricity generated in Northern Ireland using renewable sources in recent years.

Examiner Only	
Marks	Remark

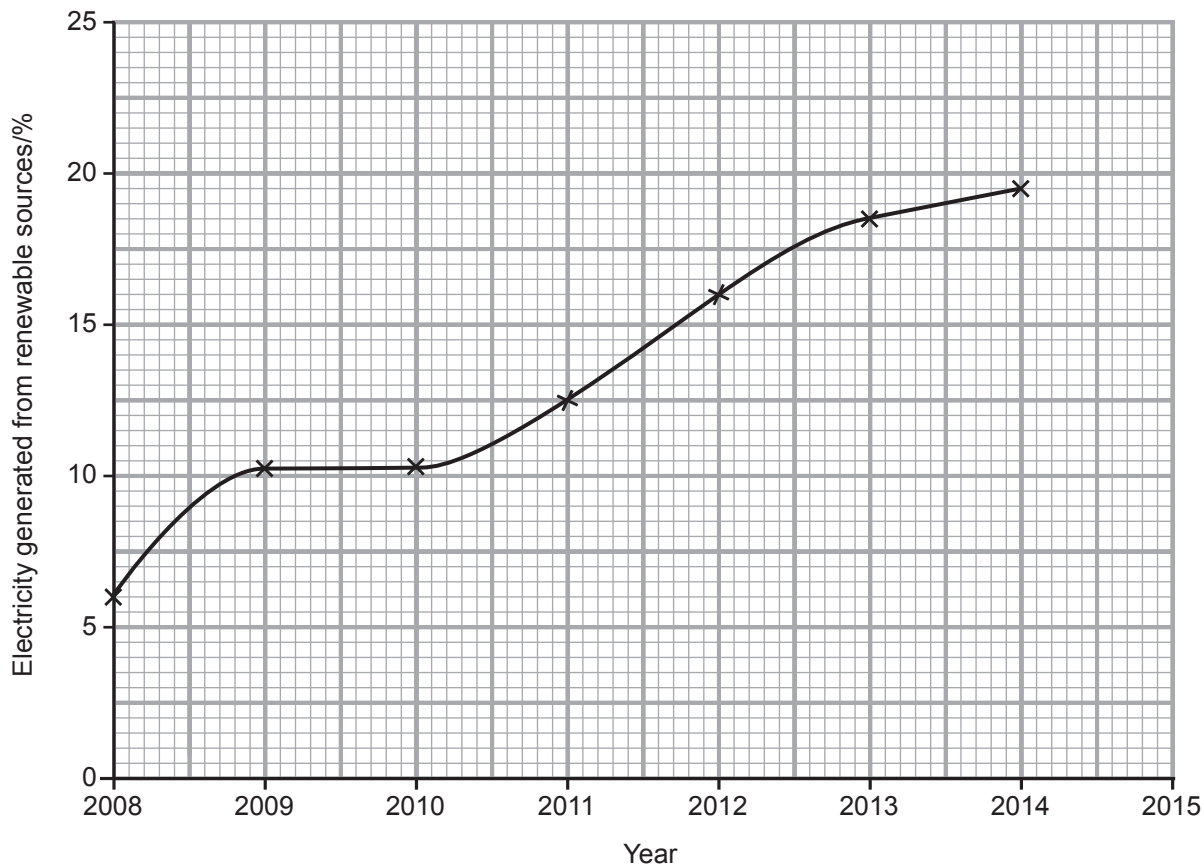

(i) Use the graph to predict the percentage of electricity generated from renewable sources in 2015.

Answer \_\_\_\_\_ % [1]

(ii) Suggest why the Northern Ireland Assembly wants more electricity produced from renewable sources.

\_\_\_\_\_  
 \_\_\_\_\_ [1]

(d) The table below shows fuels which could be used to generate heat in a house.

Fuel	Fuel cost	Energy output/ kWh	Cost per kWh/p
wood pellets	£238 per tonne	4800/tonne	4.96
heating oil	49p per litre	10/litre	4.90
bottled gas	45p per litre	7.1/litre	6.30

Which fuel would be the best value for the householder to use?  
Explain your answer.

---

---

---

[2]

Examiner Only	
Marks	Remark

**BLANK PAGE**

**(Questions continue overleaf)**

2 The half-life of carbon-14 can be used to estimate the age of an object made from wood.

Examiner Only	
Marks	Remark

(a) What is meant by the term 'half-life'?

---

---

---

[2]

The graph below shows how the activity of carbon-14 changes with time.

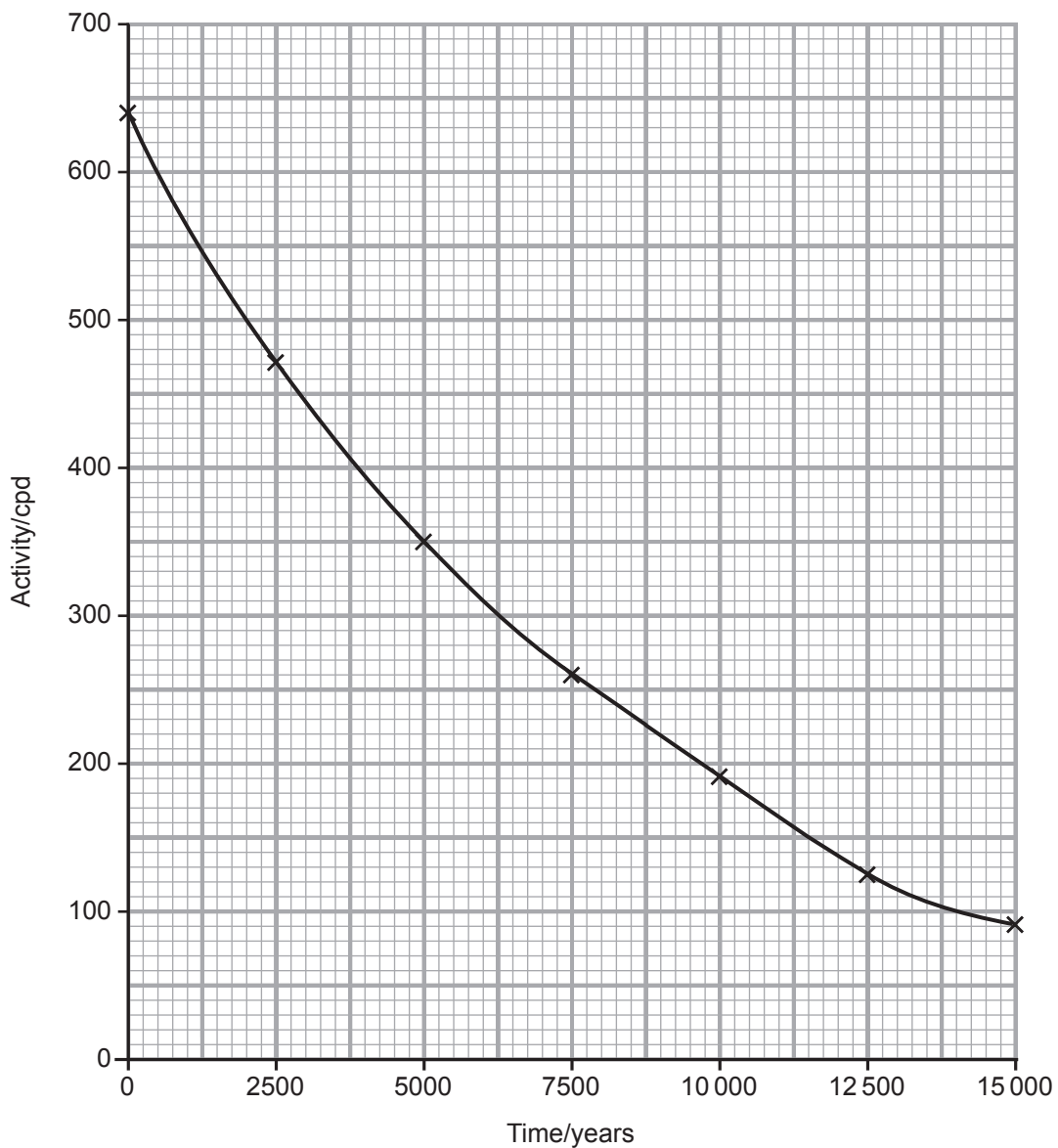

- (b) Use the graph to give the count rate of the carbon-14 after 7500 years.

Answer \_\_\_\_\_ cpd [1]

- (c) (i) Brazil nuts contain radium-226 which has a half-life of 1600 years. What fraction of the radium-226 will be left after 3200 years?

Answer \_\_\_\_\_ [1]

- (ii) The table below shows three isotopes of radium and the type(s) of radiation they emit.

Isotope	Radiation emitted
radium-224	alpha
radium-226	alpha, gamma
radium-228	beta

Describe the penetrating powers of these isotopes and how their radiation can be stopped.

---



---



---



---



---

[3]

Examiner Only

Marks	Remark
-------	--------





4 The diagram below shows the eye.

(a) Name the parts labelled **A** and **B**.

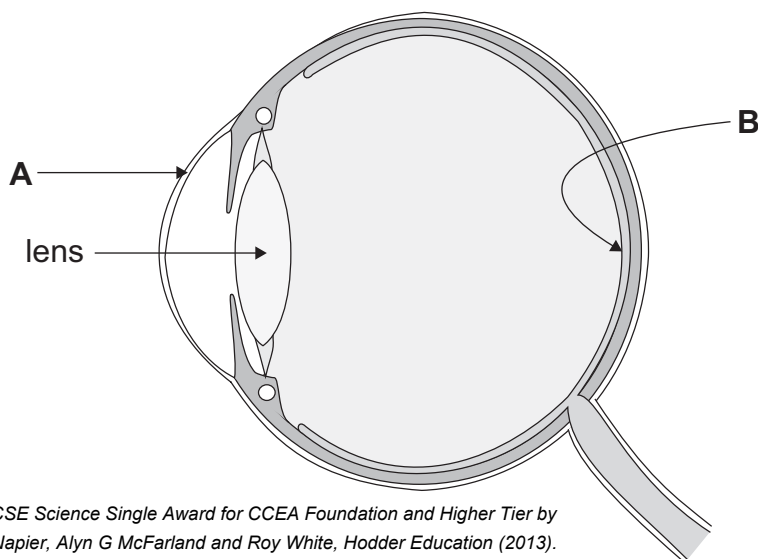

© GCSE Science Single Award for CCEA Foundation and Higher Tier by James Napier, Alyn G McFarland and Roy White, Hodder Education (2013). ISBN: 9781444195729. Reproduced by permission of Hodder Education

**A** \_\_\_\_\_

**B** \_\_\_\_\_

[2]

Long and short sight are eye defects that cause people difficulty in seeing objects clearly as shown in the table.

Person	Near object	Far object
A	blurry	clear
B	blurry	blurry
C	clear	blurry
D	clear	clear

(b) From the table above, which person **A**, **B**, **C** or **D** suffers from short sight?

Answer \_\_\_\_\_ [1]

Examiner Only	
Marks	Remark

5 The diagram below shows a wave.

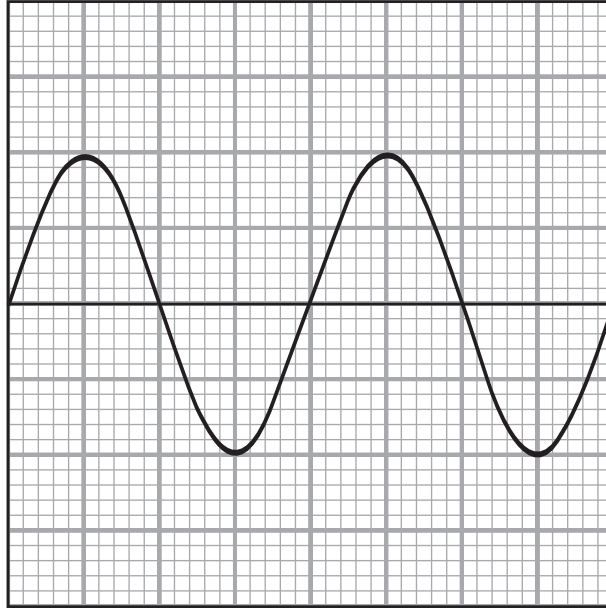

(a) On the same grid draw another wave with the same wavelength but double the amplitude of the one shown. [2]

(b) Explain what is meant by the term 'ultrasound'.

---

---

[2]

Examiner Only	
Marks	Remark

(c) The diagram below shows a car using ultrasound to help it park.

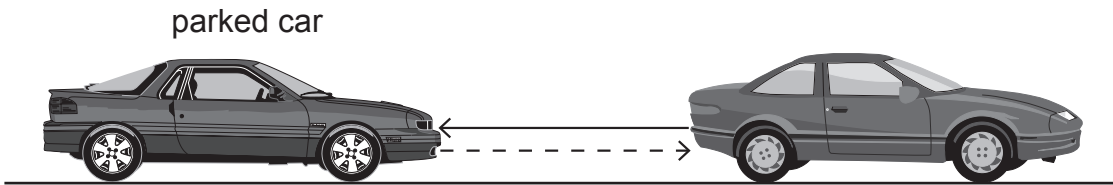

Source: Principal Examiner

The car sends an ultrasound signal to the parked car. This signal is reflected and received 0.01 s after being sent.  
The speed of ultrasound in air is 330 m/s.

Use the formula:

$$\text{distance} = \text{speed} \times \text{time}$$

to calculate the distance between the cars.

(Show your working out.)

Answer \_\_\_\_\_ m [3]

Examiner Only	
Marks	Remark

The table below shows the percentage of sound reflected by different materials at different frequencies.

		Percentage of sound reflected/%					
		125	250	500	1000	2000	4000
Material	Frequency/Hz						
Carpet		90	80	70	65	50	40
Curtains		85	88	75	65	60	55
Lino		97	97	97	97	97	98
Glass fibre tile		30	15	25	15	10	10

© CCEA

- (d) The owner of a large hall plans to use it for music concerts. He needs to improve the sound quality by using **one** of the materials from the table.

Which material should he use? Explain your answer fully.

---



---



---



---



---

[3]

Examiner Only

Marks Remark

**BLANK PAGE**

**(Questions continue overleaf)**

- 6 The diagram below shows the forces acting on a moving marble at two positions (**A** and **B**).

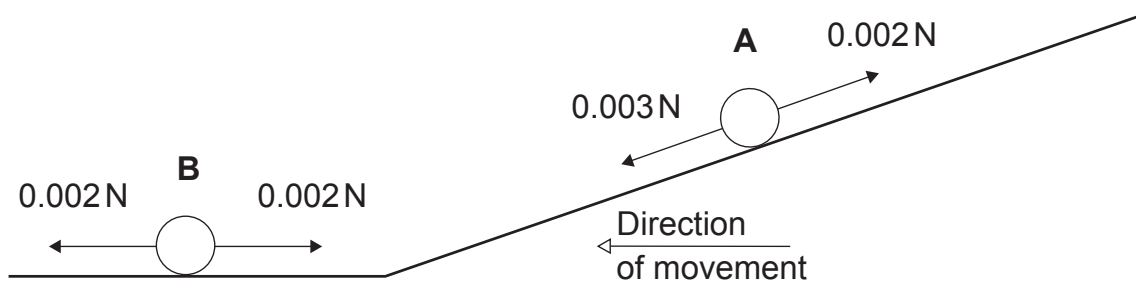

- (a) Explain fully, naming the forces, the motion of the marble at position **A**.

---

---

---

---

[3]

- (b) Explain fully, in terms of the resultant force, the motion of the marble at position **B**.

---

---

---

[2]

Examiner Only	
Marks	Remark

- (c) The marble has a momentum of  $9 \times 10^{-3}$  kg m/s and a velocity of 1.5 m/s.

Use the formula:

$$\text{momentum} = \text{mass} \times \text{velocity}$$

to calculate the mass of the marble.

(Show your working out.)

Answer \_\_\_\_\_ kg [2]

- (d) It is possible to measure both the instantaneous and average speed of marble **A**. Explain fully the difference between average speed and instantaneous speed.

---

---

---

[2]

Examiner Only

Marks

Remark

7 (a) The table below shows the height and orbital time of four satellites.

Satellite	Height above Earth's surface/km	Time to orbit the Earth/ hours
Galileo	23 000	14
GPS	20 000	12
GLONASS	19 000	11
Hubble	500	1.5

Examiner Only	
Marks	Remark

(i) On the grid below plot and draw a line graph for this information.

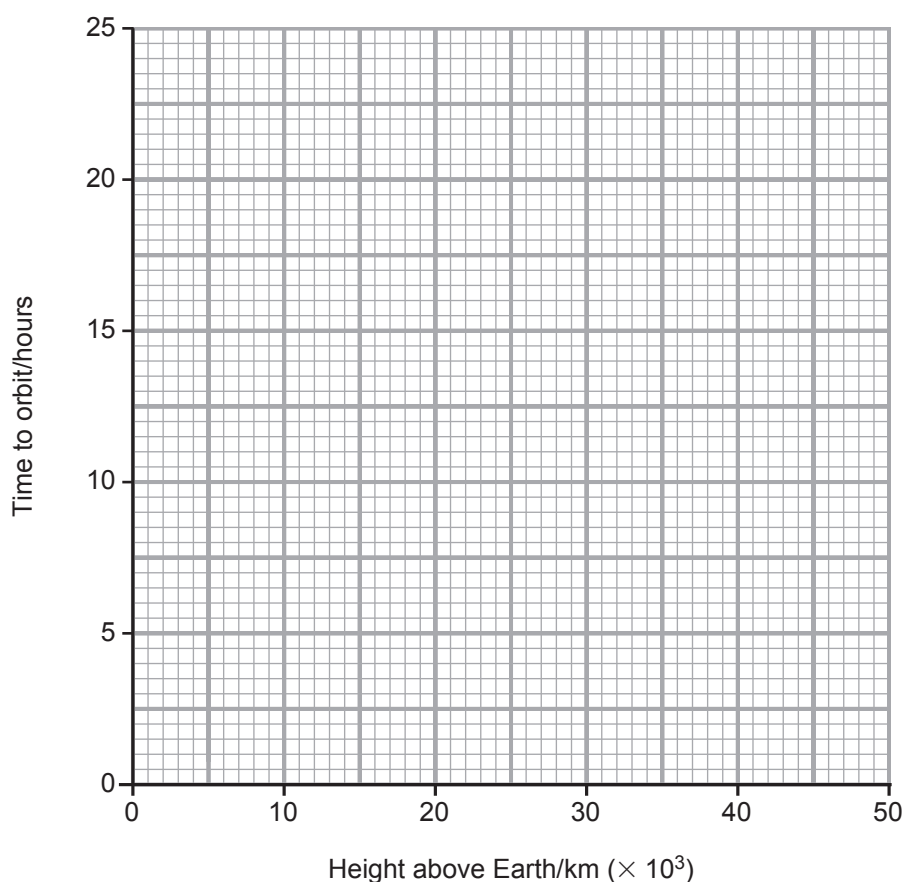

[3]

(ii) Another satellite needs to orbit the Earth every 24 hours. Use your graph to find the height above the Earth this satellite needs to be positioned.

Answer \_\_\_\_\_ km ( $\times 10^3$ ) [1]



(b) The table below gives the distance to five galaxies and the speed they are moving away from Earth.

Galaxy	Distance from Earth/ million light years	Speed away from Earth/ m/s ( $\times 10^4$ )
A	2.8	6
B	9.8	21
C	9.0	20
D	4.8	10
E	11.2	23

(i) Describe the trend shown by this data.

\_\_\_\_\_  
\_\_\_\_\_ [1]

(ii) Use the information in the table above, and your knowledge, to describe how the red-shift of galaxy **A** compares with galaxy **E**.

\_\_\_\_\_  
\_\_\_\_\_ [1]

(c) Explain fully the Big Bang theory for the formation of the Universe.

\_\_\_\_\_  
\_\_\_\_\_  
\_\_\_\_\_  
\_\_\_\_\_  
\_\_\_\_\_ [3]

(d) Name an alternative scientific theory to the Big Bang.

\_\_\_\_\_ [1]

Examiner Only	
Marks	Remark

8 (a) The diagram below shows a microwave oven.

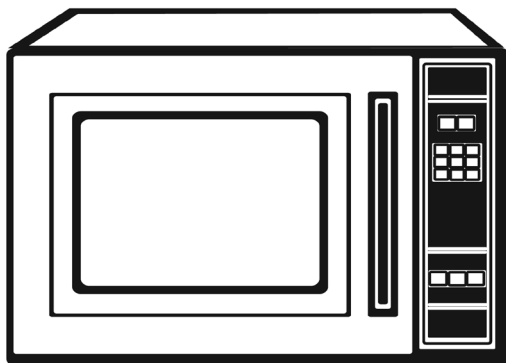

Source: Principal Examiner

Explain fully how the rays in a microwave oven heat food.

---



---



---



---



---

[3]

(b) Shown below are the frequencies and wavelengths of some electromagnetic waves.

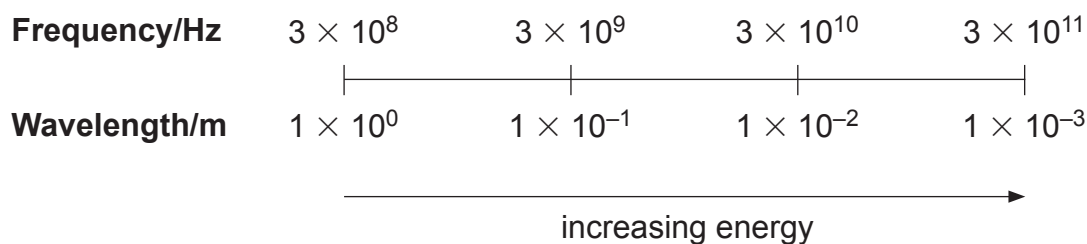

Microwave ovens can use frequencies of  $9.15 \times 10^8$  Hz or  $2.44 \times 10^9$  Hz. Suggest which of these frequencies would heat food quicker. Explain your answer fully.

---



---



---

[2]

Examiner Only	
Marks	Remark

(c) The label below was found on the back of a microwave oven.

Stainless Steel Microwave Oven  
 Model: MSS6216  
 230–240 V  
 1200 W

Describe fully how the electrical cost of using this appliance is calculated.

You may find the following formula useful.

$$\text{Cost} = \text{number of units (kWh)} \times \text{cost per unit (p)}$$

In your answer you will need to state what additional information is required.

**In this question you will be assessed on your written communication skills including the use of specialist scientific terms.**

---

---

---

---

---

---

---

---

---

---

---

---

---

---

---

---

---

---

---

---

---

---

[6]

Examiner Only	
Marks	Remark

- 9 (a) Shown below are two types of electrical circuit, each containing identical bulbs.

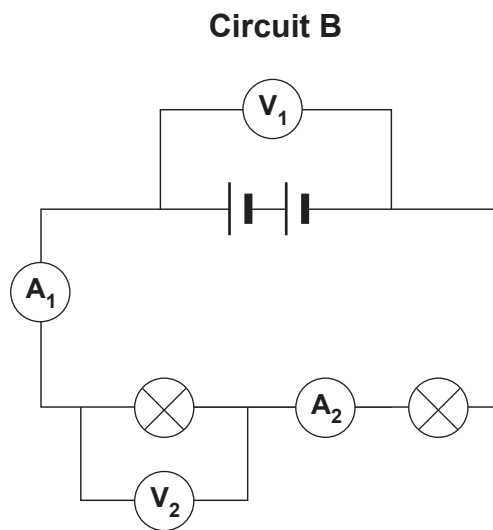
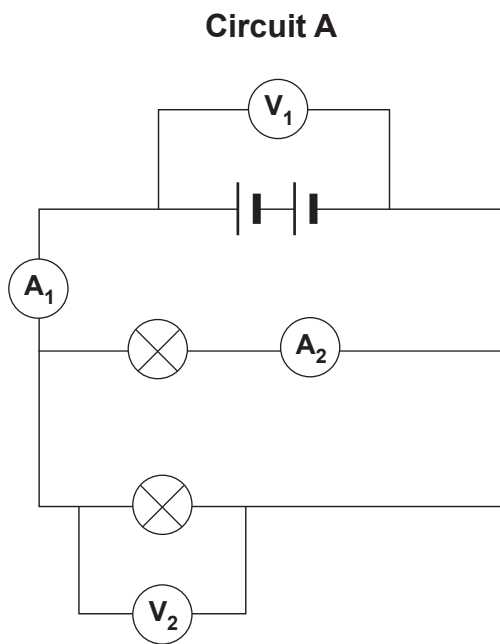

Complete the table below.

Circuit	$V_1/V$	$V_2/V$	$A_1/A$	$A_2/A$
<b>A</b>	6	6	4	
<b>B</b>	6		1	

[3]

- (b) Explain fully the difference between conventional and actual current flow.

---



---



---



---

[3]

Examiner Only

Marks Remark

(c) The diagram below shows part of the electricity grid.

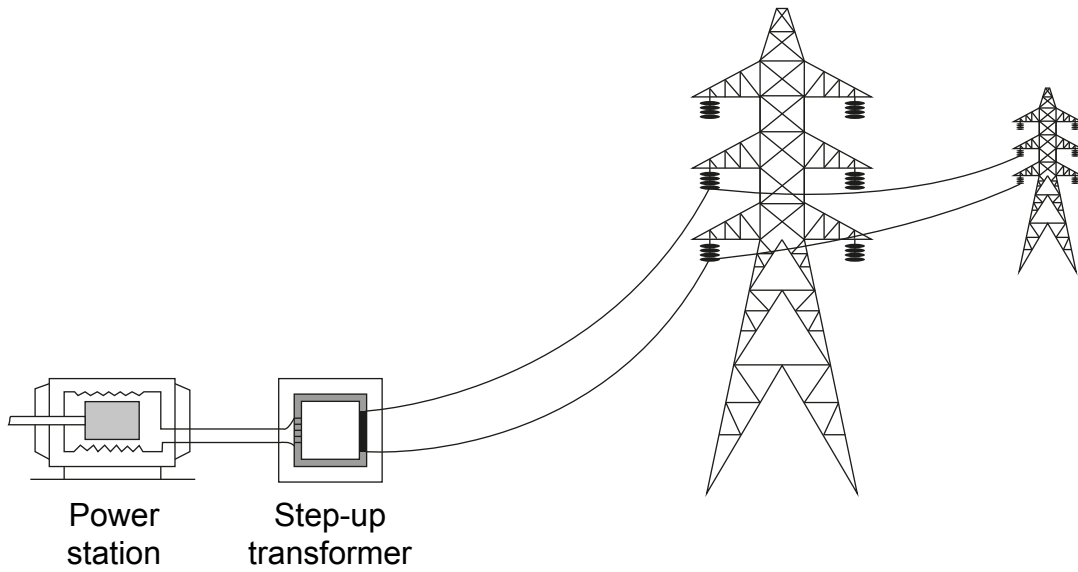

© GCSE Physics for CCEA, Second Edition by Frank McCauley and Roy White, Hodder Education (2012). ISBN:9781444176483. Reproduced by permission of Hodder Education

Explain fully why this transformer is used in the grid.

---

---

---

[2]

---

**THIS IS THE END OF THE QUESTION PAPER**

---

Examiner Only	
Marks	Remark





Permission to reproduce all copyright material has been applied for.  
In some cases, efforts to contact copyright holders may have been unsuccessful and CCEA  
will be happy to rectify any omissions of acknowledgement in future if notified.