



Rewarding Learning

General Certificate of Secondary Education
2015–2016

Centre Number

--	--	--	--	--

Candidate Number

--	--	--	--	--

Science: Single Award

Unit 3 (Physics)

Foundation Tier

MV18

[GSS31]

WEDNESDAY 25 MAY 2016, AFTERNOON

Time

1 hour, plus your additional time allowance.

Instructions to Candidates

Write your Centre Number and Candidate Number in the spaces provided at the top of this page.

You must answer the questions in the spaces provided.

Complete in blue or black ink only.

Answer **all nine** questions.

Information for Candidates

The total mark for this paper is 60.

Figures in brackets printed at the end of each question indicate the marks awarded to each question or part question.

Quality of written communication will be assessed in Question **9(a)**.

1 The diagram below shows the human eye.

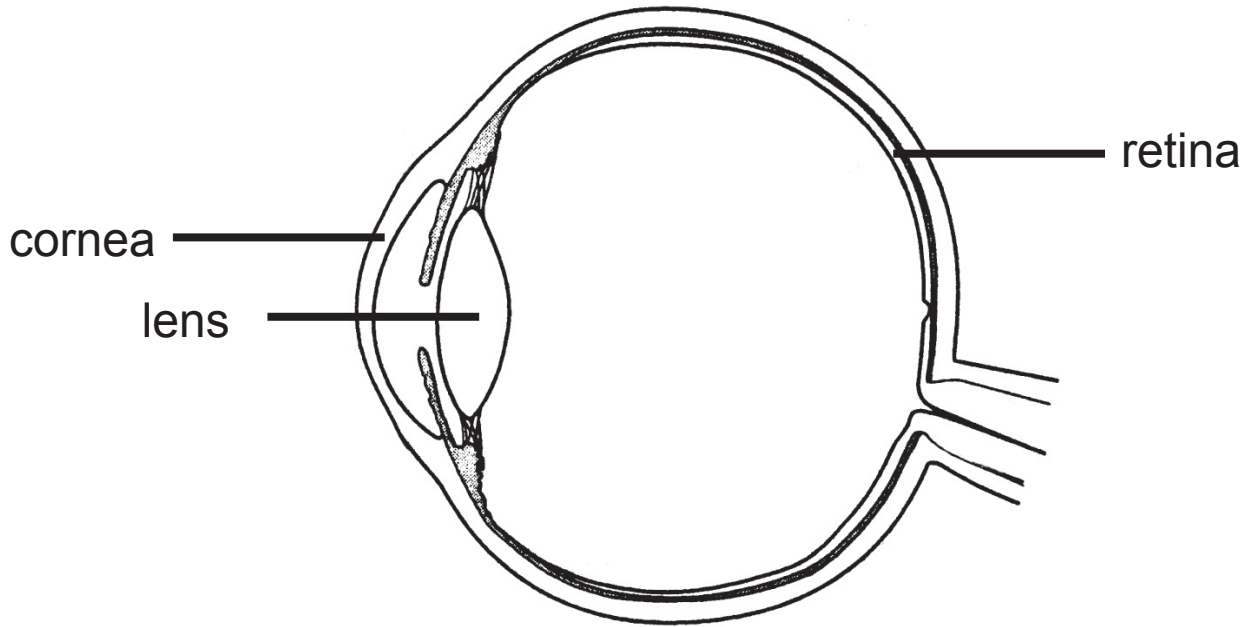

(a) Using lines, match the following parts of the eye with their main function. [2 marks]

Part

Function

cornea

controls the amount of light entering the eye

retina

image forms here

bends light

(b) Name the type of lens found in the human eye.

Circle the correct answer. [1 mark]

contact

convex

concave

(c) Which diagram (**A**, **B** or **C**) below correctly shows what this lens does to light? [1 mark]

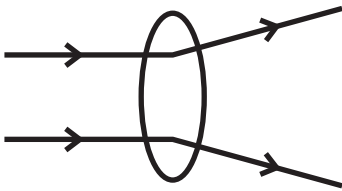

A

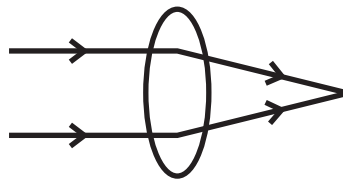

B

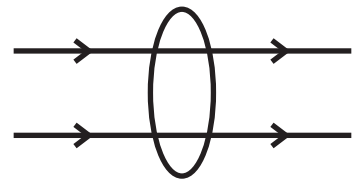

C

Answer _____

2 (a) The diagrams (A, B, C and D) below represent sound waves recorded over the same length of time.

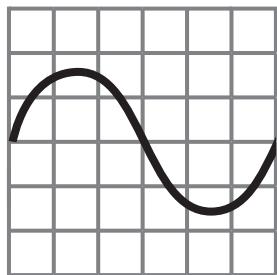

A

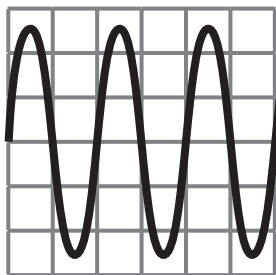

B

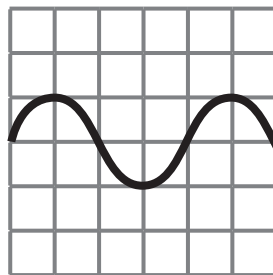

C

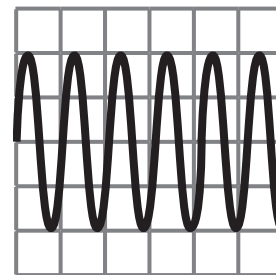

D

(i) Which sound wave has the shortest wavelength?
[1 mark]

Answer _____

(ii) Which sound wave has the highest frequency?
[1 mark]

Answer _____

(iii) Which sound wave is the loudest? [1 mark]

Answer _____

(b) Pupils investigated the speed of sound by making a loud noise and waiting for the sound to be reflected off a wall. They measured the time between making the noise and hearing its reflection as 2 seconds.

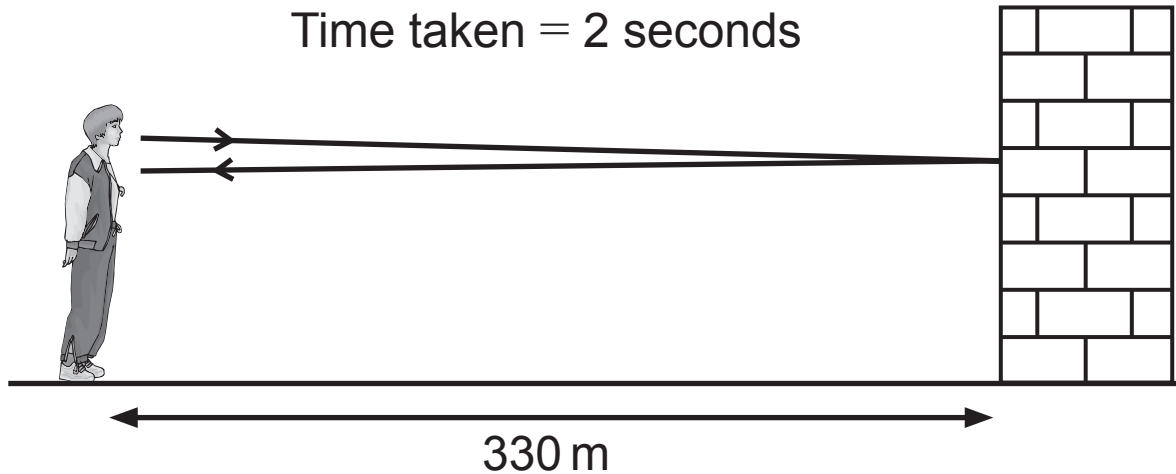

(i) Use the equation:

$$\text{speed of sound} = \frac{\text{distance sound travels}}{\text{time}}$$

to calculate the speed of sound. [2 marks]

(Show your working out.)

Answer _____ m/s

(ii) What name is given to a reflected sound?
[1 mark]

- 3 (a) The table below shows some results from an investigation to find the most efficient energy source for a car.

Energy source	Input energy/J	Output energy/J	
		Useful	Wasted
petrol	500	150	350
gas	500		270
battery	500	350	150
diesel	500	290	

- (i) Complete the table. [2 marks]
- (ii) Use information from the table to state **one** thing that was done to ensure a fair test. [1 mark]

- (iii) Which energy source is the most efficient?
Explain your answer. [2 marks]

(b) Complete the following sentences. [2 marks]

Choose from:

carried changed destroyed transmitted created

The conservation of energy states that energy cannot be _____ or _____.

It can only be _____ from one type to another.

4 (a) Shown below is a distance–time graph for a train.

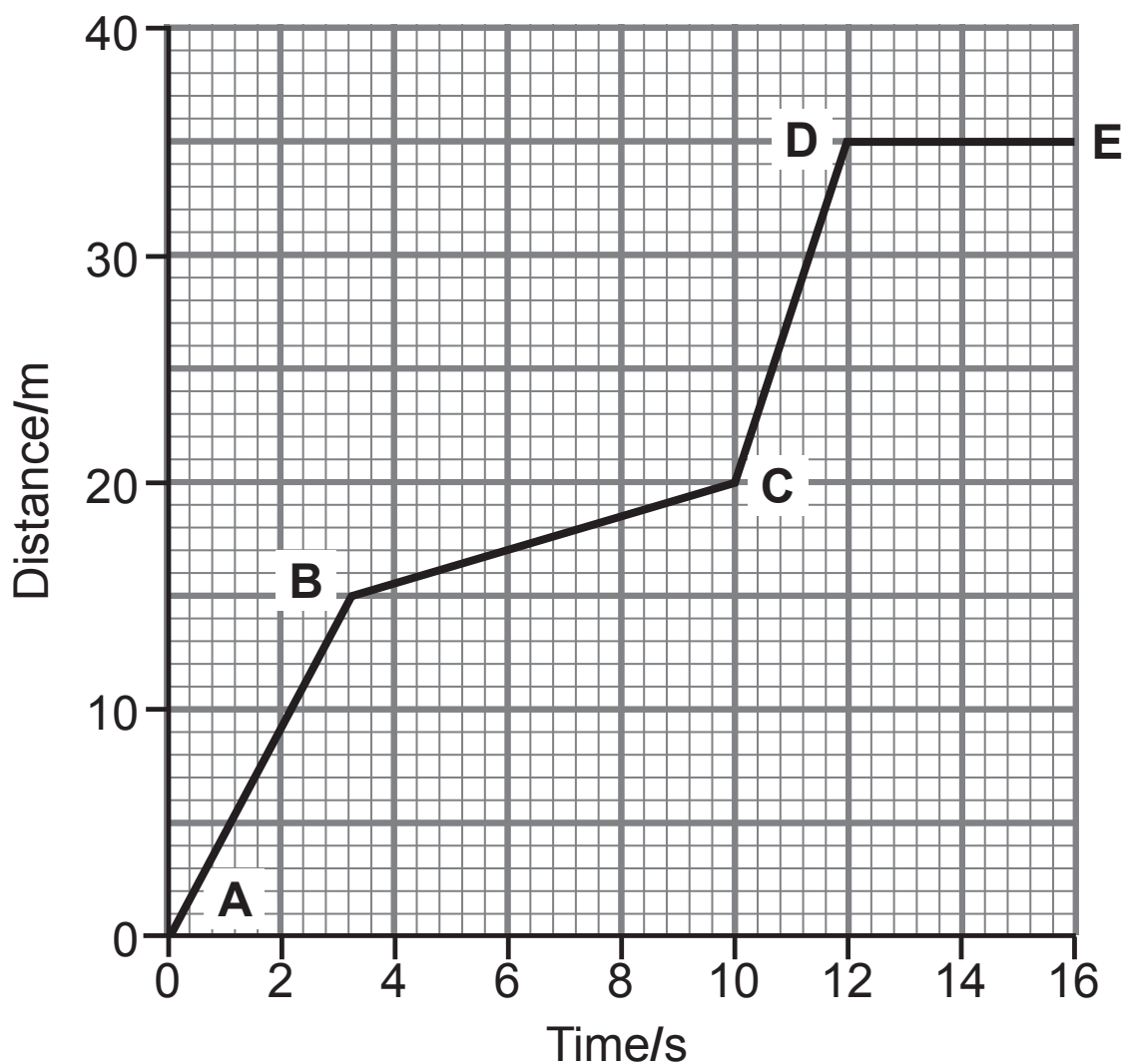

Use the graph to answer the following questions.

- (i) How long did the train take to travel the first 15 m?
[1 mark]

Answer _____ s

(ii) Use the equation:

$$\text{average speed} = \frac{\text{distance}}{\text{time}}$$

to calculate the average speed of the train for the first 10 seconds. [2 marks]

(Show your working out.)

Answer _____ m/s

(iii) Between which two positions is the train travelling the fastest? [1 mark]

Choose from:

A – B

B – C

C – D

D – E

Answer _____

(iv) Describe the movement of the train, if any, between **D** and **E**.

Explain your answer. [2 marks]

- (b) Police use fixed position and mobile (in police vans) cameras to detect speeding vehicles.

The table below shows the number of drivers caught by each method over a four year period in one region.

Year	Number of drivers caught speeding		
	using fixed position cameras	using mobile cameras	total
2010	78	44	122
2011	67	61	128
2012	50	95	145
2013	25	129	154

- (i) State the trend shown in the table for **mobile** cameras. [1 mark]

- (ii) Suggest **one** reason for the trend shown by the **fixed position** speed cameras. [1 mark]

5 (a) The diagram below shows an electrical circuit diagram.

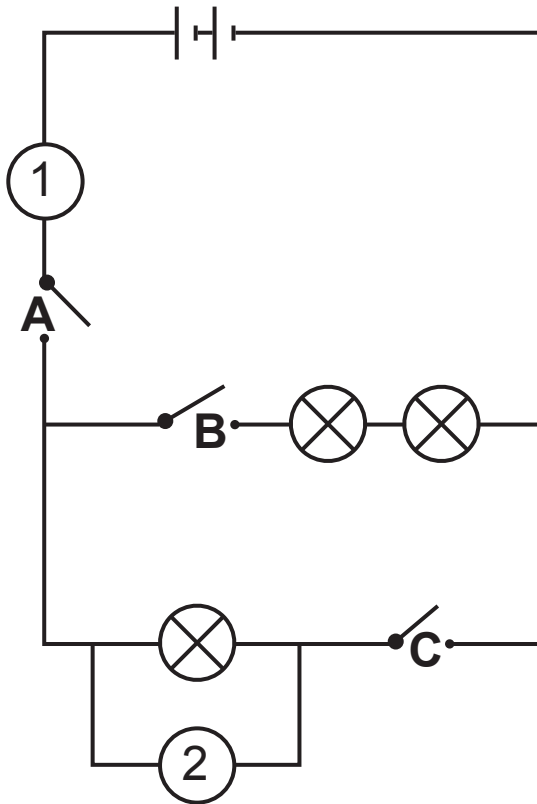

Use the diagram and your knowledge to answer the following questions.

(i) Which two switches must be closed to light only **one** bulb? [1 mark]

Answer _____ and _____

(ii) Meters **1** and **2** shown in the circuit can be used to calculate resistance. [2 marks]

Name meters **1** and **2**.

Meter **1** _____

Meter **2** _____

(iii) What is the unit of resistance? [1 mark]

Choose from:

amp

watt

ohm

volt

Answer _____

(b) The 3-pin plug shown below contains a fuse of unknown size.

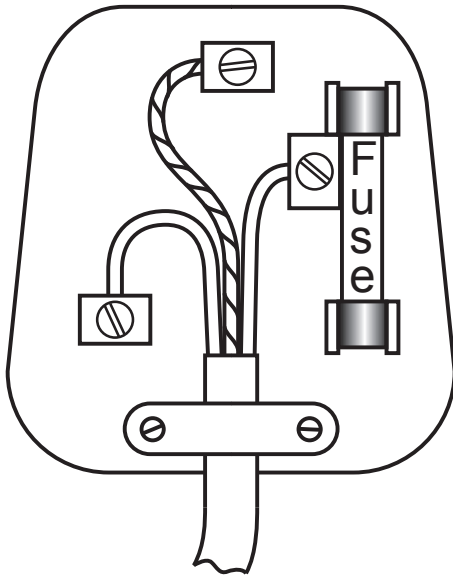

(i) Apart from the fuse, name **one** other safety feature shown in this plug. [1 mark]

To find the fuse size, a range of currents were passed through the fuse and the observations made are shown in the table below.

Current/A	Description of fuse wire
2	grey and cold
4	red and warm
6	yellow, glowing and hot
8	grey, cold and melted (broken)

Use the information provided and your knowledge to answer the following questions.

(ii) Explain fully how a fuse works. [2 marks]

(iii) What size of fuse has been used in this plug?

Circle the correct answer. [1 mark]

3A

5A

7A

9A

6 (a) The advert below was used to discourage drink driving.



(i) Suggest how drink driving could lead to a person losing his or her job. [1 mark]

(ii) Describe and explain how alcohol affects a driver's thinking distance. [2 marks]

(b) The table below shows how the braking distance and the thinking distance may be affected by the number of people in a car at different speeds.

Speed/ km/h	Braking distance/m		Thinking distance/m	
	car and driver only	car, driver and three passengers	car and driver only	car, driver and three passengers
30	5	7	6	6
45	12	14	8	8
60	21	23	11	11

(i) Explain what is meant by the term 'braking distance'.
[1 mark]

(ii) In what way, if any, is braking distance affected by having passengers? [1 mark]

(iii) Calculate the **stopping** distance for a car with a driver and three passengers travelling at 30 km/h.
[1 mark]

Answer _____ m

- 7 (a) The graph below shows the output power produced by a wind turbine at different wind speeds.

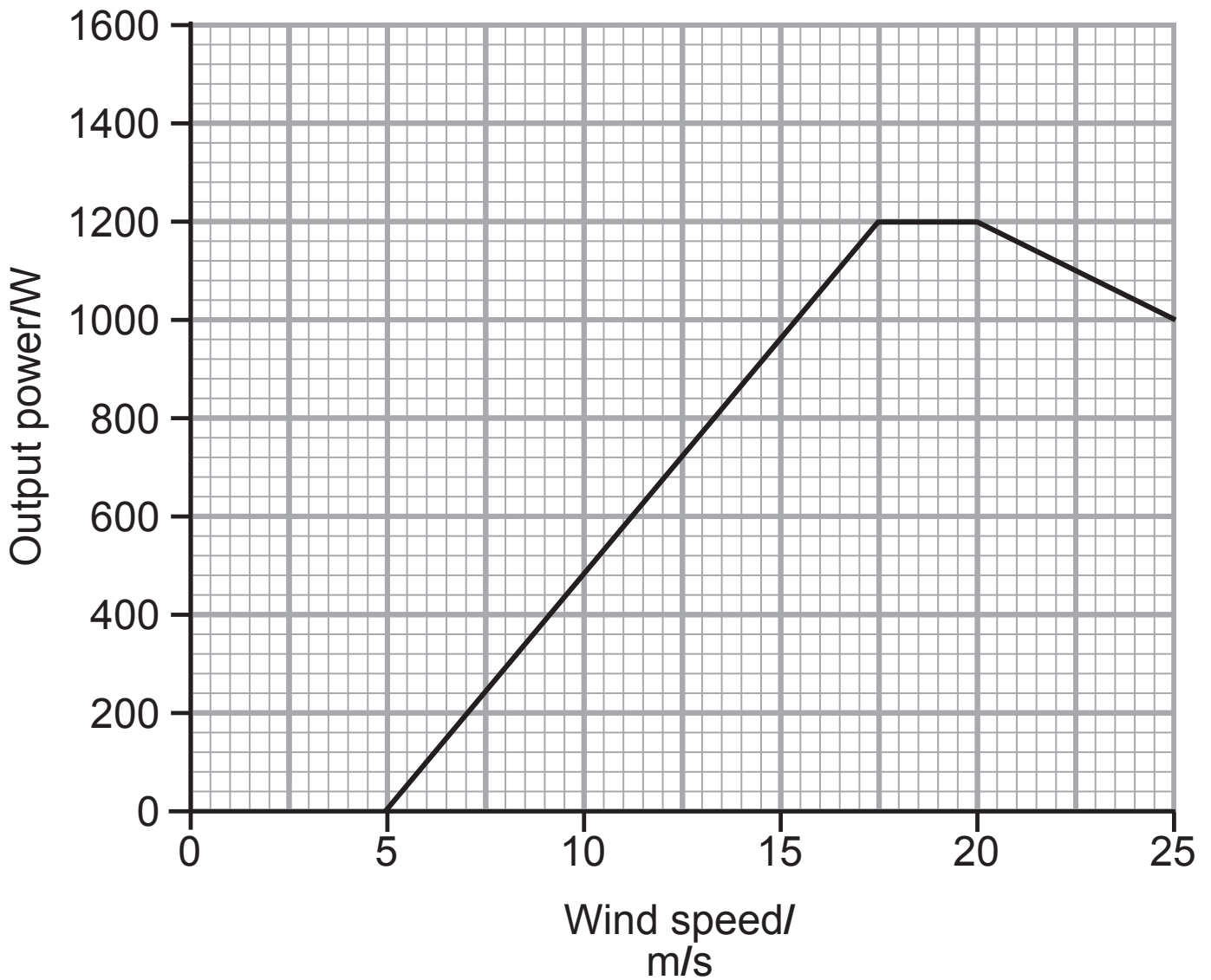

- (i) Describe fully the trend shown by the graph.
[2 marks]

The diagram below shows a cross section through a wind turbine.

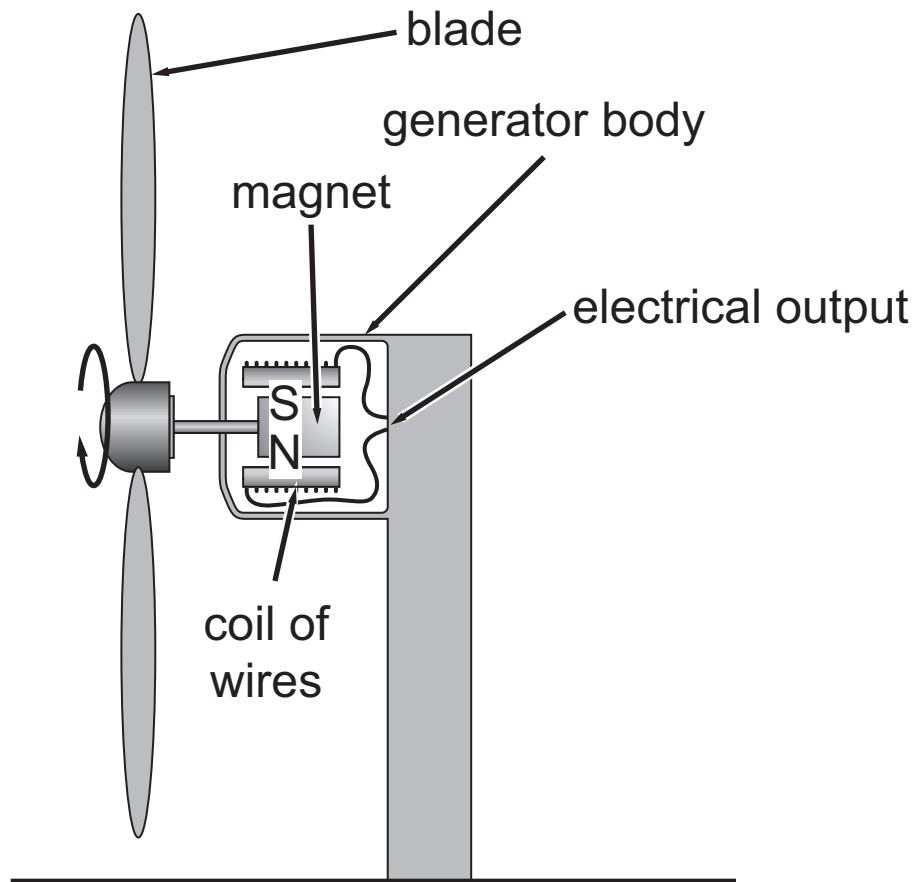

(ii) Use the diagram and your knowledge to describe how electricity is produced by this turbine. [2 marks]

(b) Give **one** environmental advantage and **one** environmental disadvantage of using wind turbines. [2 marks]

Advantage _____

Disadvantage _____

- 8 (a) The diagram below shows a badge that is used to detect radiation.
The badge has four windows.

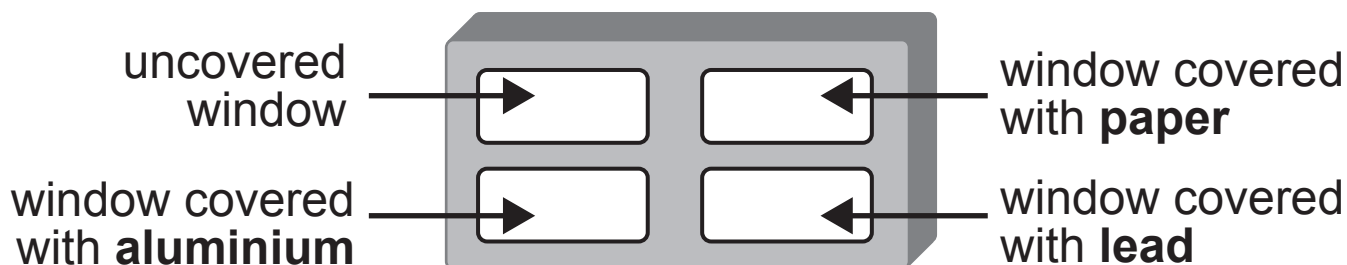

Behind each window there is a film that is sensitive to radiation. This film changes colour from brown to white when exposed to radiation.

- (i) Suggest the function of the uncovered window.
[1 mark]

- (ii) How many windows will change from brown to white when exposed to **beta** radiation? [1 mark]

Answer _____

- (b) Surgical equipment can be treated with radiation before it is used in hospital operations.
Suggest why this is necessary, naming the type of radiation used. [3 marks]

(c) The table below shows the results of an investigation into the activity of a radioactive isotope.

Day	Activity/cpm
1	100
2	73
3	50
4	37
5	25
6	18
7	15
8	15
9	15
10	15

Describe fully the trend shown by this information.
[2 marks]

(b) Our Universe consists of millions of galaxies.

(i) What is a 'galaxy'? [1 mark]

(ii) Name the galaxy that includes planet Earth.
[1 mark]

THIS IS THE END OF THE QUESTION PAPER
