



Rewarding Learning

General Certificate of Secondary Education
2013–2014

Science: Single Award

Unit 1 (Biology)

Higher Tier

[GSS12]



MONDAY 24 FEBRUARY 2014, MORNING

Centre Number

71	
----	--

Candidate Number

--

TIME

1 hour 15 minutes.

INSTRUCTIONS TO CANDIDATES

Write your Centre Number and Candidate Number in the spaces provided at the top of this page.

Write your answers in the spaces provided in this question paper.

Answer **all nine** questions.

INFORMATION FOR CANDIDATES

The total mark for this paper is 75.

Figures in brackets printed down the right-hand side of pages indicate the marks awarded to each question or part question.

Quality of written communication will be assessed in question **4(b)** and **8(b)**.

For Examiner's use only

Question Number	Marks
1	
2	
3	
4	
5	
6	
7	
8	
9	

Total Marks

--

BLANK PAGE

1 (a) The diagram below shows a food web.

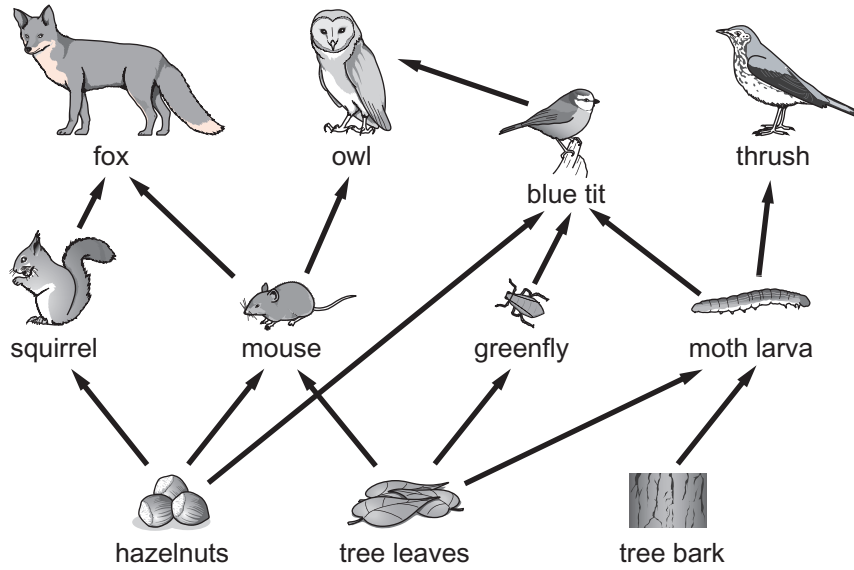

© KS3 science revision Level 5-7 by Patricia Millar, published by HarperCollins, 2006.
Reprinted by permission of HarperCollins Publishers Ltd

(i) Using the diagram, complete a food chain containing **four** organisms in the boxes below.

→ → →

[2]

(ii) Name **one** primary consumer from this food web.

_____ [1]

(b) Suggest what might happen to the number of squirrels if the fox numbers go down. Explain your answer.

_____ [2]

Examiner Only	
Marks	Remark

--	--

2 The diagram summarises how a vaccine works.

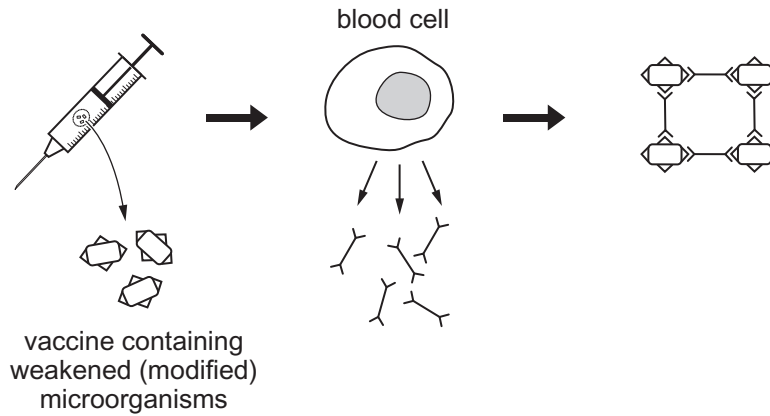

(a) Using the diagram and your knowledge describe how vaccinations protect against disease.

[3]

(b) Before a vaccination is licensed for use it goes through a number of trials (in vitro, animal and clinical).

(i) Clinical trials test the drug on human volunteers. Give **two** reasons why it is necessary to carry out testing on humans.

1. _____

2. _____

[2]

(ii) Suggest **one** reason why many people are against testing on animals.

_____ [1]

Examiner Only	
Marks	Remark

The table below shows information about the development and production of different drugs by a company.

	Antibiotics	Painkillers	Other medical drugs
Cost of producing drug/million pounds	7.4	7.5	4.9
Time to produce drug/years	9.5	6.5	6.5
Profit per drug/million pounds	2.1	2.9	4.2
Number of drugs in development	2	4	7

(c) Using the information provided, suggest **two** reasons why this company is more interested in developing 'other medical drugs' rather than antibiotics and painkillers.

1. _____

2. _____

_____ [2]

(d) Explain fully why some antibiotics have become less effective in recent years.

_____ [2]

Examiner Only	
Marks	Remark

- 3 Cannabis is the most widely used illegal drug in Britain. Some doctors think that taking cannabis can lead to depression.

Doctors investigated the use of cannabis by 800 males and 800 females who had used the drug. The results are shown below.

Usage in one year	Men who became depressed/%	Women who became depressed/%
Less than 5 times	8	18
More than 5 times	12	20
1–4 times per week	14	34
Every day	20	67

- (a) Using the information in the table complete the bar chart below.

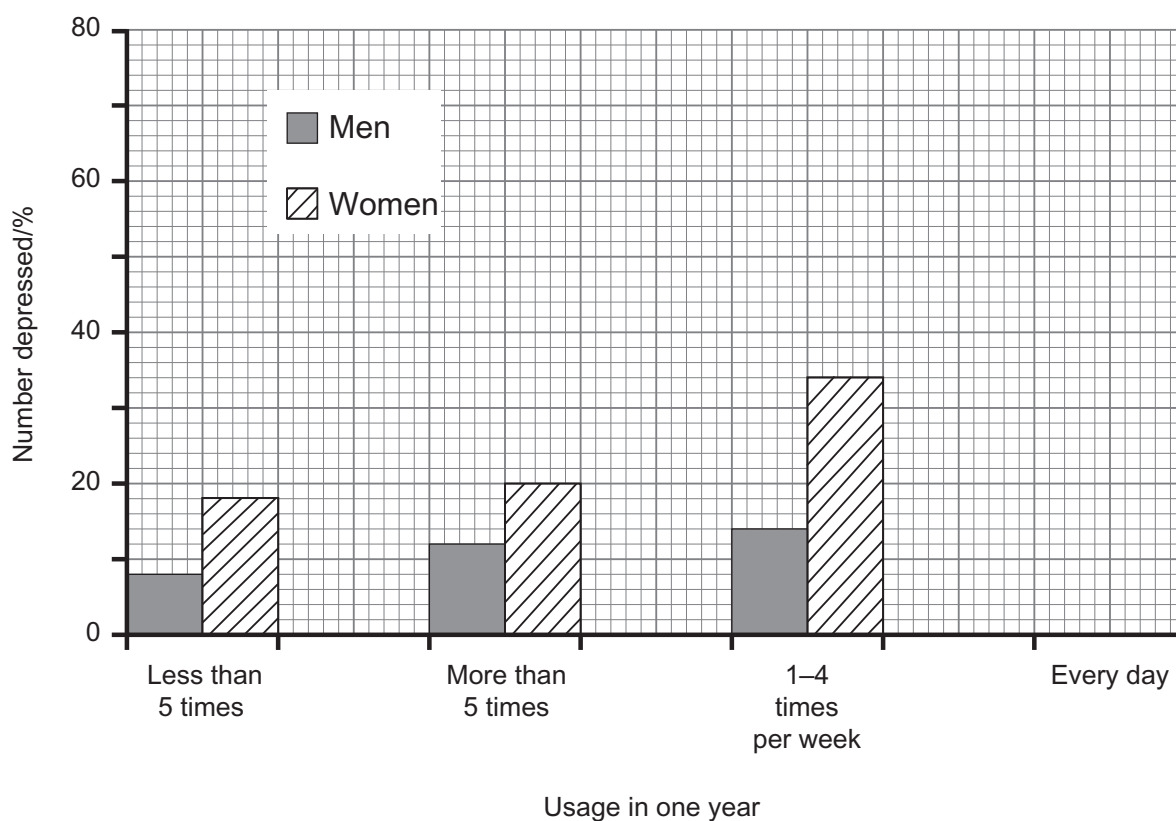

[1]

Examiner Only	
Marks	Remark

Examiner Only	
Marks	Remark

4 (a) Abiotic factors can be used to measure the rate at which global warming is occurring.

(i) What is meant by the term 'abiotic'?

_____ [1]

(ii) Apart from temperature, name **one** abiotic factor which could be used to measure the rate of global warming.

_____ [1]

(b) The diagram below shows a simple carbon cycle.

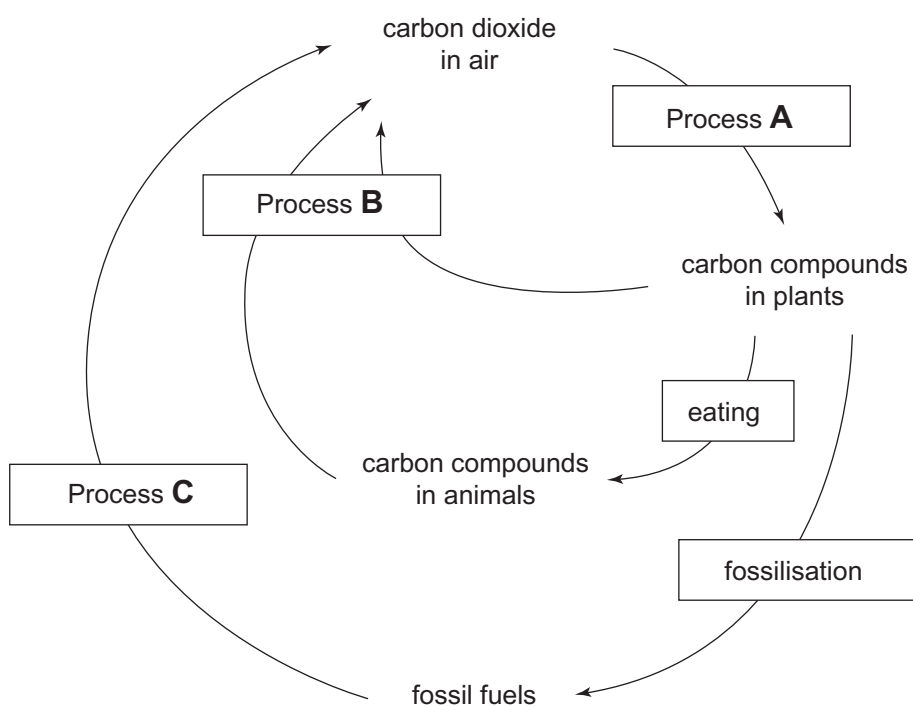

Using the diagram and your knowledge, explain the carbon cycle.

Your answer should include:

- the names of the processes labelled **A**, **B** and **C**,
- and how it has become unbalanced causing increased levels of carbon dioxide.

- 5 (a) Complete the table below about food groups and their function in the body.

Food group	Function in the body
	growth and repair
carbohydrate	
	to give us energy and for insulation (reduce heat loss)

[3]

- (b) (i) Describe fully how you would carry out a food test for sugar.

_____ [2]

- (ii) Describe the colour change that would occur if the food contains sugar.

_____ to _____ [1]

Examiner Only	
Marks	Remark

BLANK PAGE
(Questions continue overleaf)

6 Plants with desirable features can be grown asexually by using the method of tissue culture described in the following diagram.

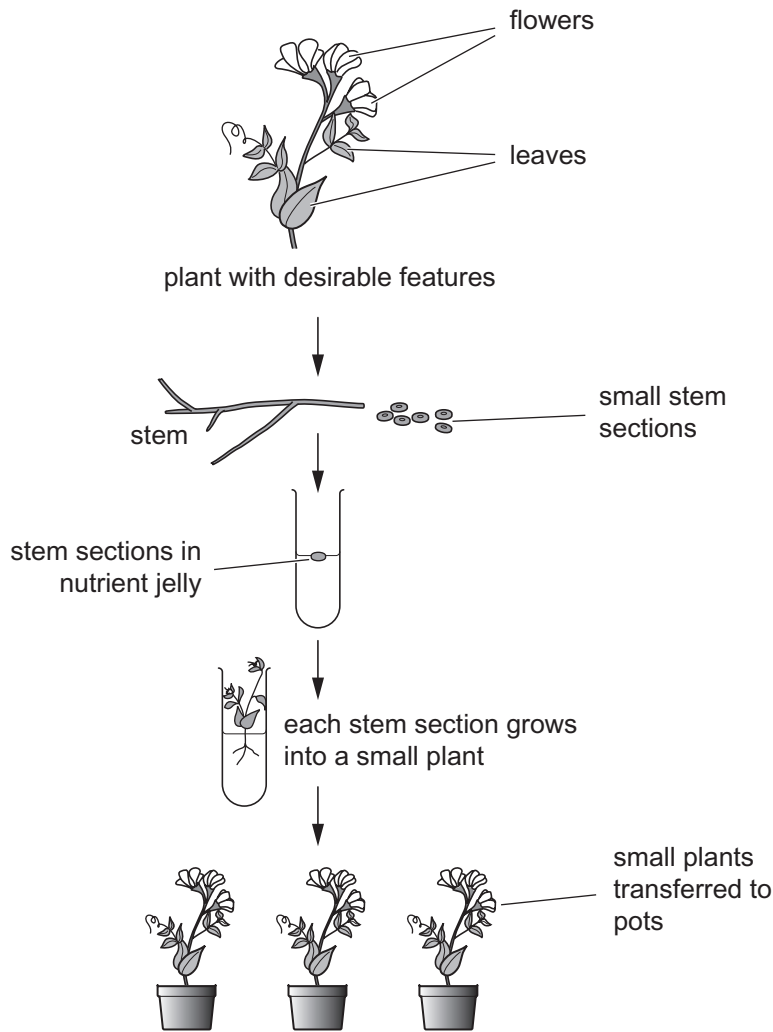

© GCSE Biology for CCEA (Second edition) by J Napier, published by Hodder Education, 2011.
ISBN 978 0340 983805, "Reproduced by permission of Hodder Education"

(a) Suggest **one** desirable feature the plant could have.

_____ [1]

Examiner Only	
Marks	Remark

- 7 (a) The graph below shows how a sewage leak affected the level of nitrate in a section of river.

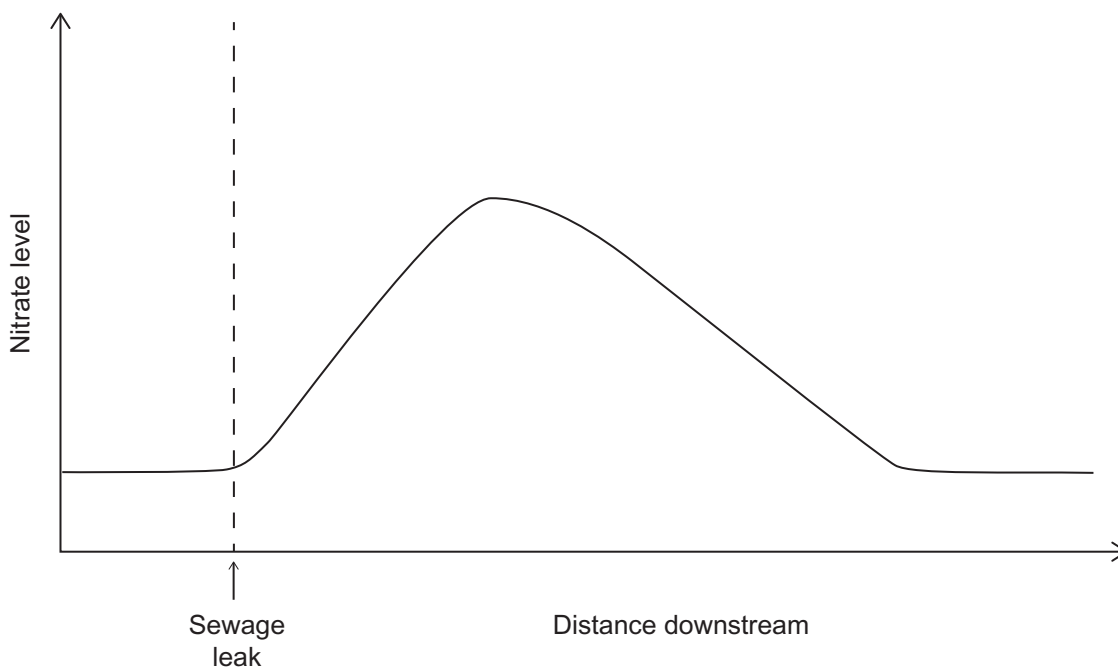

- (i) In terms of the nitrogen cycle, explain fully why the nitrate level rises after the sewage leak.

[3]

- (ii) Suggest **two** reasons why the nitrate level in the water eventually returns to normal.

1. _____

2. _____ [2]

Examiner Only	
Marks	Remark

- (b) Acid rain is another example of pollution. The table below shows the percentage of a Scottish forest damaged by acid rain over the last 50 years.

Year	Area of forest damaged/%
1960	20
1970	27
1980	30
1990	25
2000	15
2010	15

- (i) Describe how the percentage area of forest damaged changed over time.

[2]

- (ii) Explain fully the reason for the change in percentage of forest damaged between the years 1980–2000.

[2]

- (iii) What is the evidence from the table that acid rain is still produced?

[1]

- (c) Acid rain causes trees to lose their leaves. Suggest **one** reason why the leaves are the main part of a tree affected by acid rain.

[1]

Examiner Only

Marks Remark

- 8 (a) The following diagram shows how the levels of atmospheric oxygen have changed throughout the last 2.5 billion years.

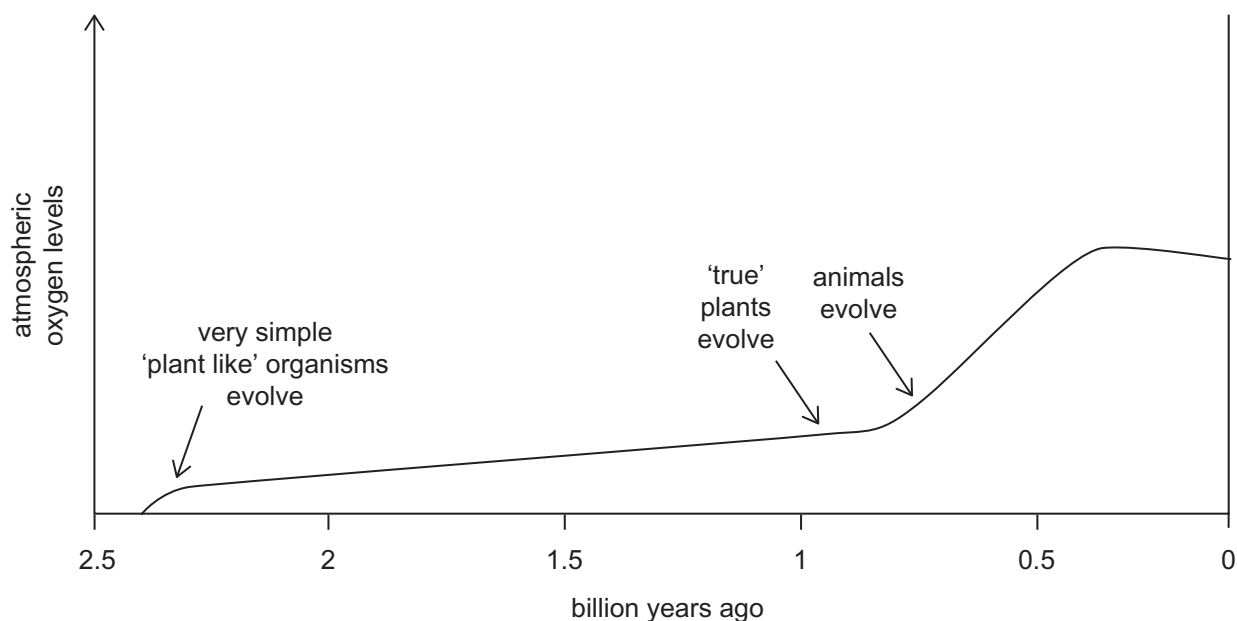

- (i) Name the process that caused the rise in oxygen levels around 2.4 billion years ago.

[1]

- (ii) Using the information provided and your knowledge, explain why animals evolved around 0.75 billion years ago.

[2]

Examiner Only	
Marks	Remark

9 Huntington's disease is caused by the presence of a dominant allele in a particular gene.

(a) Complete the Punnett square and the offspring genotypes and phenotypes for:

- a father who is heterozygous for Huntington's disease
- a mother who does not have the Huntington allele.

Use the symbols: H = Huntington allele; h = normal allele

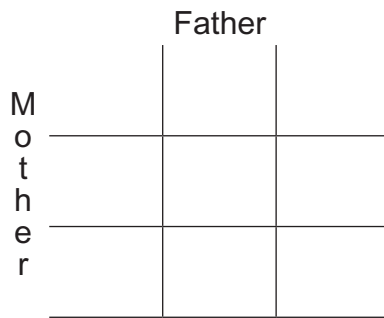

Offspring genotypes _____

Offspring phenotypes _____

[4]

(b) The following pedigree diagram shows the inheritance of Huntington's disease in a particular family.

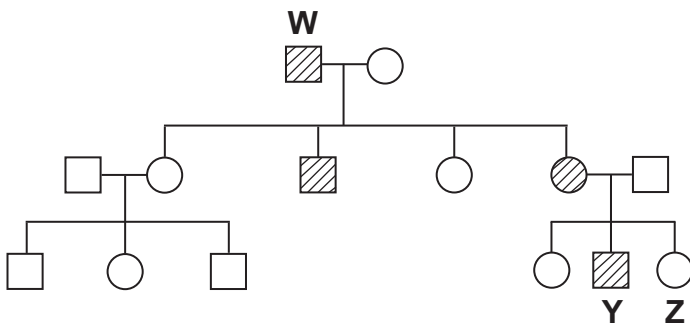

Key

- normal male
- normal female
- male with Huntington's disease
- female with Huntington's disease

(i) What is the relationship of individual Y to W?

[1]

(ii) What is the genotype of individual Z? Explain your answer.

Genotype _____

Explanation _____

_____ [2]

Examiner Only	
Marks	Remark

--	--

(c) Huntington's disease leads to a gradual breakdown of the nervous system in middle age. There is no cure at present. It is possible to have a test to show if an individual will develop the disease.

(i) What general name is given to the process of testing for the possibility of developing inherited diseases?

_____ [1]

(ii) Suggest **one** reason why an 18 year old male, whose mother is starting to develop Huntington's disease, would decide **not** to have the test to show if he will develop the disease.

_____ [1]

(d) Some genetic diseases (e.g. cystic fibrosis) can be treated by gene therapy. Describe what gene therapy is and give **one** reason why its effect as a treatment is limited.

_____ [3]

THIS IS THE END OF THE QUESTION PAPER

Examiner Only

Marks Remark

Permission to reproduce all copyright material has been applied for.
In some cases, efforts to contact copyright holders may have been unsuccessful and CCEA
will be happy to rectify any omissions of acknowledgement in future if notified.