



Centre Number

71	
----	--

Candidate Number

--

General Certificate of Secondary Education  
2013–2014

---

## Science: Single Award

Unit 3 (Physics)

Foundation Tier

[GSS31]

MV18

WEDNESDAY 26 FEBRUARY 2014, MORNING

---

### TIME

1 hour, plus your additional time allowance.

### INSTRUCTIONS TO CANDIDATES

Write your Centre Number and Candidate Number in the spaces provided at the top of this page.

Write your answers in the spaces provided in this question paper.  
Answer **all nine** questions.

### INFORMATION FOR CANDIDATES

The total mark for this paper is 60.

Figures in brackets printed at the end of each question indicate the marks awarded to each question or part question.

Quality of written communication will be assessed in Question 7.

- 1 (a) Below are some electrical symbols. Using lines, match each symbol with its correct description. [2 marks]

**Symbol**

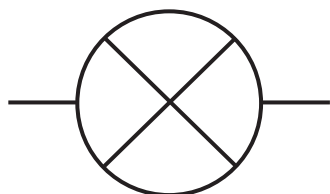
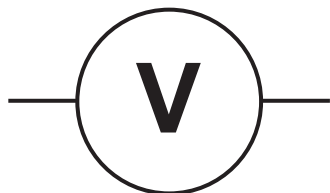

**Description**

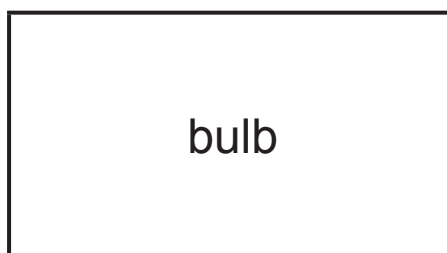
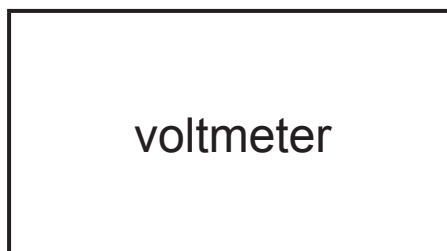
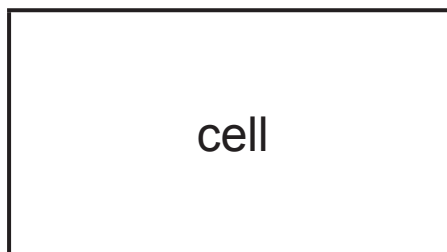

(b) The diagram below was set up to measure the resistance of a resistor.

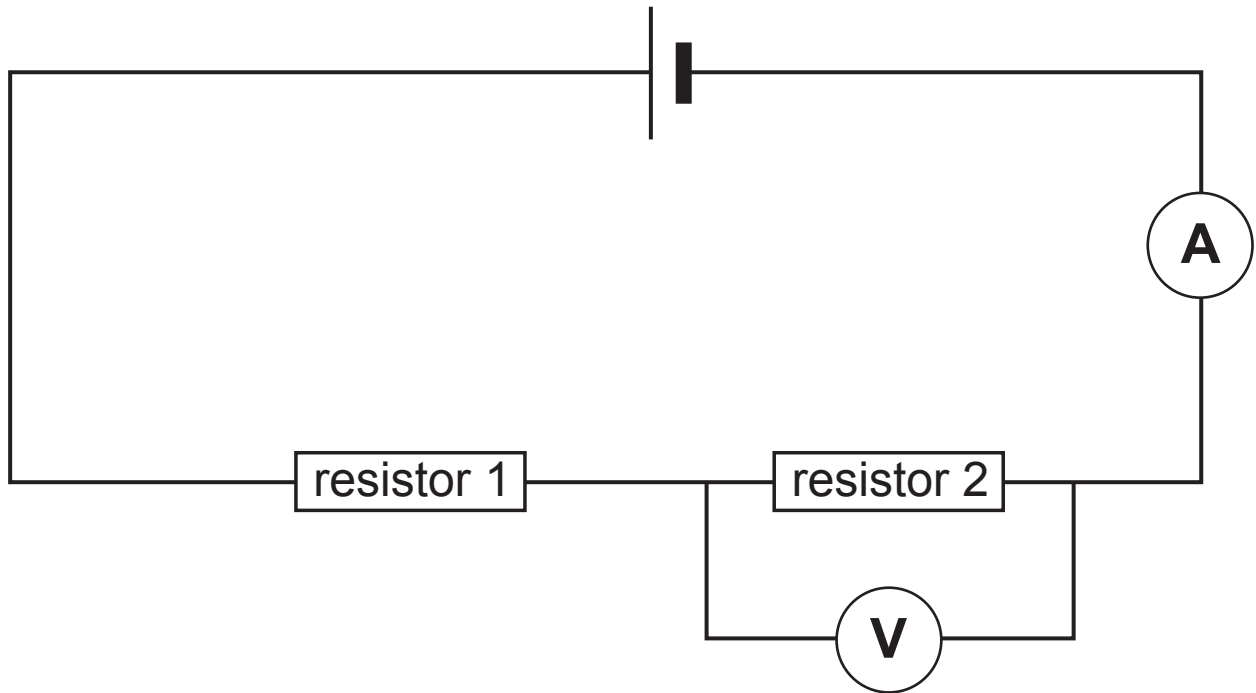

(i) Complete the following sentence. [1 mark]

Choose from:

**series**

**short**

**parallel**

In the diagram above the resistors are connected in a \_\_\_\_\_ circuit.

- (ii) The voltmeter had a reading of 2 V and the ammeter had a reading of 4 A. [2 marks]

Use the equation:

$$\text{resistance} = \frac{\text{voltage}}{\text{current}}$$

to calculate the resistance of resistor 2.  
(Show your working out.)

Answer \_\_\_\_\_

- (iii) Name the unit of resistance. [1 mark]

Choose from:

**volt**      **watt**      **amp**      **ohm**

Answer \_\_\_\_\_

**BLANK PAGE**

**(Questions continue overleaf)**

2 (a) The diagram below gives stopping distances for a car travelling at different speeds on a **dry** road.

(i) Use the equation:

**thinking distance + braking distance = stopping distance**

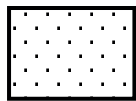

thinking distance

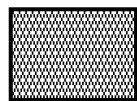

braking distance



stopping distance

to complete the diagram below. [2 marks]

Two answer boxes need completed.

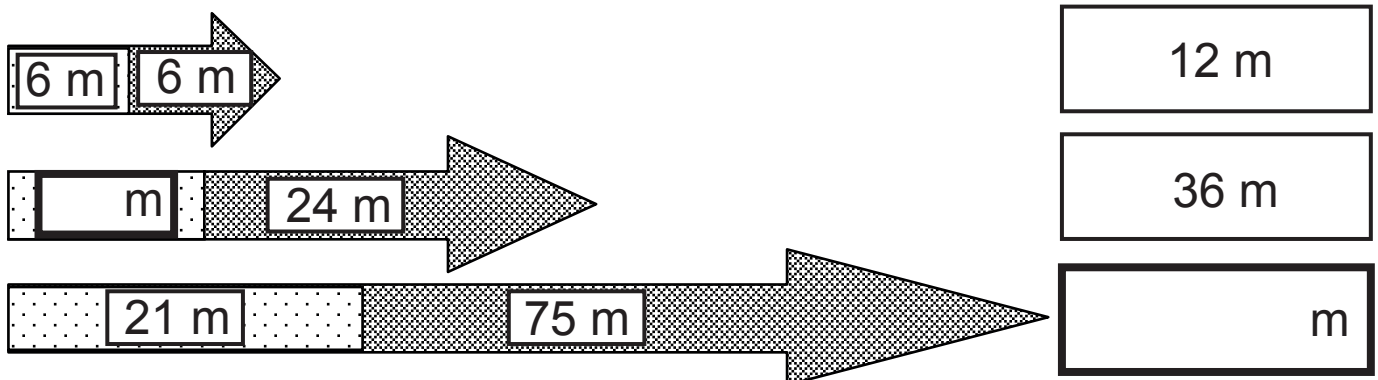

(ii) If the road was **wet**, what effect, if any, would this have on the:

braking distance?

---

thinking distance?

---

stopping distance?

---

[3 marks]

(b) The table below shows the stopping distance for different depths of tyre tread.

Tread depth/mm	Stopping distance/m
8.0 (new tyre)	25.9
3.0 (part worn)	31.7
1.6 (legal limit)	39.5

Use the information to state how stopping distance changes as tread depth decreases. [1 mark]

---

---

(c) The diagram below shows a car moving to the right.

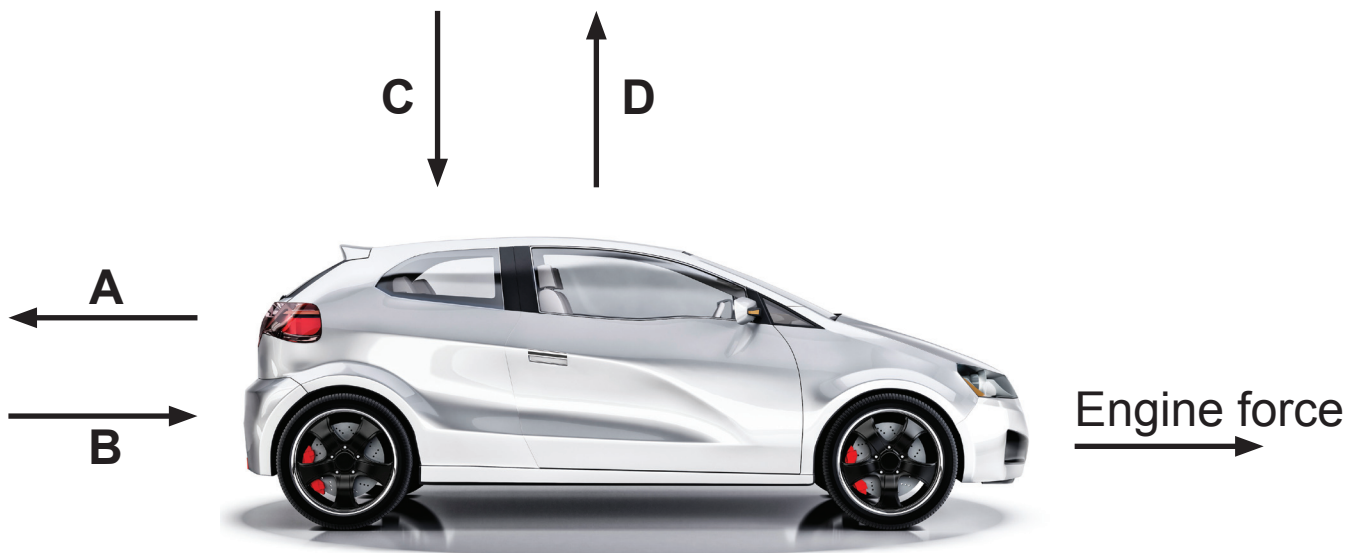

Which arrow **A**, **B**, **C** or **D** shows the direction of the force of friction? [1 mark]

Answer \_\_\_\_\_

- 3 A group of students investigated how energy drinks affect reaction times. The same student carried out the test for each drink.

The results are shown in the table below.

Drink	Reaction time before taking drink/ms	Reaction time after taking drink/ms
Water	315	316
Energy drink A	321	298
Energy drink B	318	288

- (a) (i) Using the information, describe the effect of energy drinks on reaction times. [1 mark]

---

---

- (ii) Compare the effect of energy drink A and energy drink B on reaction times. [1 mark]

---

---

- (b) Suggest why reaction times before and after drinking water were measured. [1 mark]

---

---



**(c)** Why was the same student used for each test? [1 mark]

---

---

**(d)** State how the reliability of the investigation could be improved. [1 mark]

---

- 4 The photograph below shows a speaker which produces sound waves.



- (a) Complete the following sentence. [2 marks]

Choose from:

**reflections      vibrations      energy      pictures**

All sound waves are caused by \_\_\_\_\_  
and they carry \_\_\_\_\_ from one  
place to another.

- (b) Suggest which feature of a sound wave increases as the volume of the sound gets louder. [1 mark]

Circle the correct answer.

**frequency      amplitude      wavelength**

(c) The table below shows the percentage of sound reflected at different frequencies for different materials.

Percentage of sound reflected at different frequencies				
Material	250 Hz	500 Hz	1 kHz	2 kHz
Brick	98	97	96	95
Carpet	76	43	31	29
Curtain	65	42	30	28
Glass	75	82	88	93

(i) Which material reflects most sound over a range of frequencies? [1 mark]

---

(ii) A concert hall needs to reduce echoes to improve sound quality.  
Use the information and your knowledge to suggest which material should be used.  
Explain your answer. [3 marks]

---

---

---

---

- (d) (i) The table below shows the electromagnetic spectrum.  
Complete the table using the words given below.  
[2 marks]

**infrared**

**microwaves**

**ultraviolet**

gamma rays	X-rays		visible light			radio waves
------------	--------	--	---------------	--	--	-------------

- (ii) State **one** feature these waves have in common.  
[1 mark]

---

- (iii) State **one** feature that is different for each of these waves. [1 mark]

---

(e) Electromagnetic waves can be used in communications.  
Using lines, match each wave with how it is used.  
[2 marks]

**Wave**

**Use**

infrared

television aerial

optical fibre

microwave

satellite

- 5 Pilots are exposed to higher levels of radiation because they spend long periods of time at high altitudes (heights).



The table below shows the amount of radiation (dose) received by pilots travelling to different destinations from Belfast.

<b>Destination</b>	<b>Flight time/hrs</b>	<b>Amount of radiation/mSv</b>
Paris	1.75	8.34
New York	7.7	50.00
Sharm El Sheikh	6.2	24.18
Manchester	1.0	1.82

(i) State the trend shown by this data. [1 mark]

---

---

(ii) Background radiation causes this increase in dose. Suggest **one** possible source of radiation which could affect the pilots at this height. [1 mark]

---

---

(iii) The maximum safe radiation dose for pregnant women is 2000 mSv.

Use this information to calculate the maximum number of return flights a woman should make to New York during a pregnancy. [2 marks]

(Show your working out.)

Answer \_\_\_\_\_

**(iv)** Explain fully how radiation can harm humans. [2 marks]

---

---

---

---



**BLANK PAGE**

**(Questions continue overleaf)**

- 6 (a) The table below shows the count rate of a radioactive isotope.

Time/days	Count rate/cps
0	120
2	76
4	48
6	30
8	19

- (i) Plot these points on the axes opposite and draw a curve of best fit. [3 marks]
- (ii) Use the graph opposite to find the half-life of the radioactive isotope. [1 mark]

Answer \_\_\_\_\_ days

- (b) Radioactive phosphorus has a half-life of 20 days. What fraction of the original mass of phosphorus will be left after 40 days? [1 mark]

Answer \_\_\_\_\_

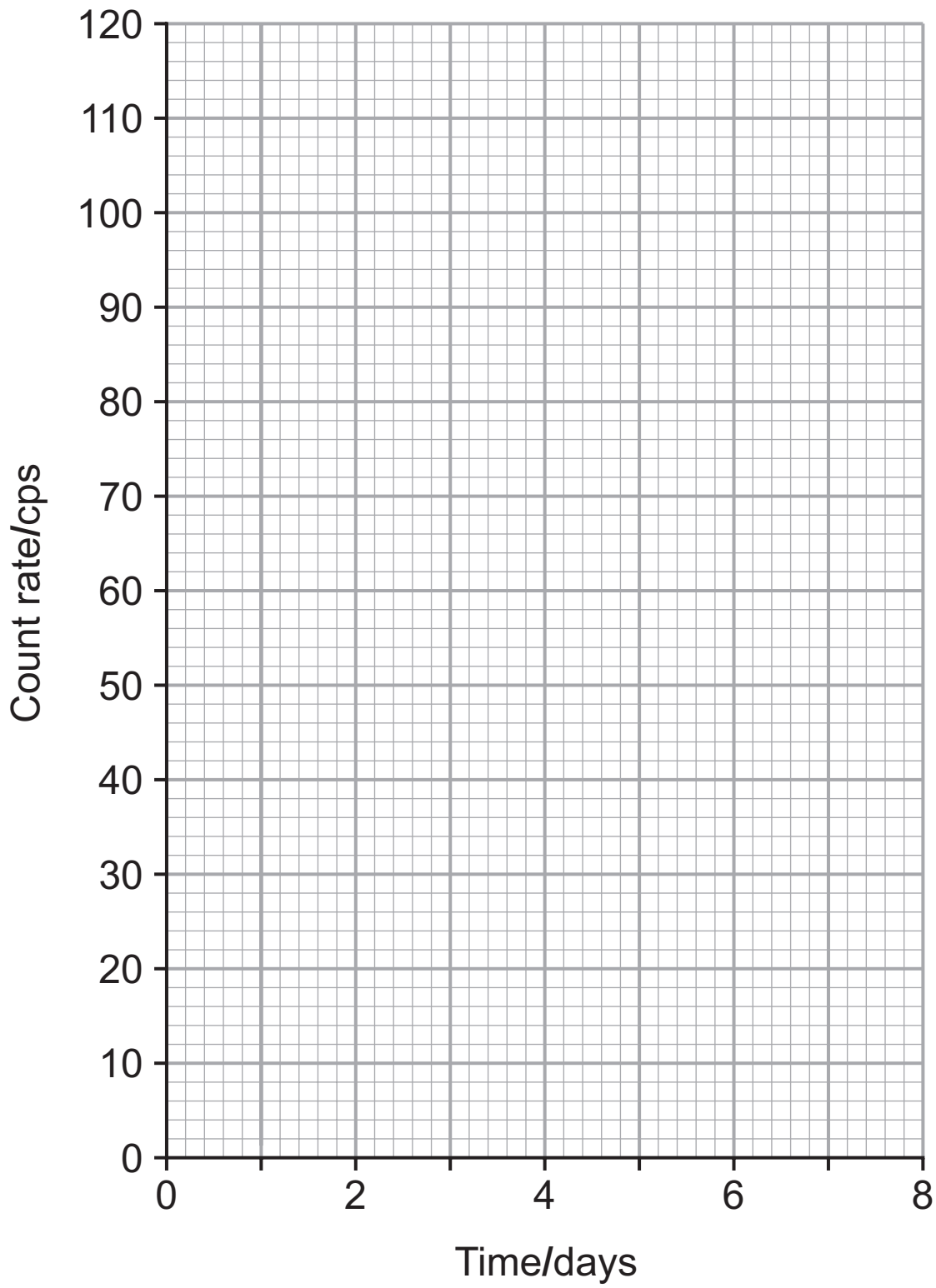

7 The photograph below shows the Sun, our closest star.

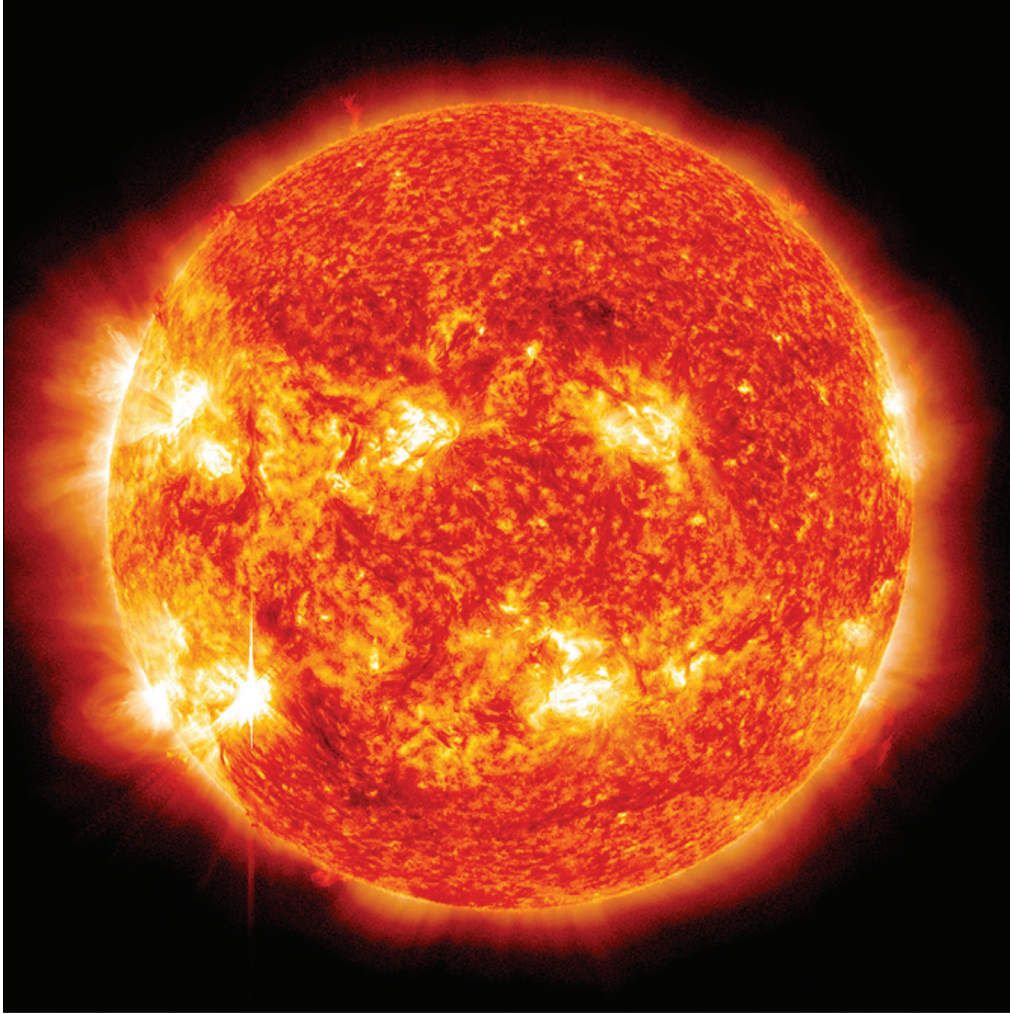

Describe fully the formation of the Sun, naming the gases and forces involved. [6 marks]



8 (a) The table below shows information on generating electrical power.

	Tidal	Coal	Wind	
			Onshore	Offshore
<b>Power output/ MW</b>	12	1600	24	94
<b>Life expectancy/ years</b>	15	30	20	20
<b>Annual operating costs per kW/£</b>	56	24	24	57
<b>Generating costs per kWh/p</b>	6.63	3.33	5.35	7.19

(i) The government want to replace fossil fuel power stations with alternative sources. Use the information to explain fully why this might not be the best option. [3 marks]

---

---

---

---

---

**(ii)** Give **two** reasons why more alternative energy sources are being introduced. [2 marks]

1. \_\_\_\_\_

\_\_\_\_\_

2. \_\_\_\_\_

\_\_\_\_\_

**(b)** Explain fully the formation of fossil fuels from dead plants and animals. [2 marks]

\_\_\_\_\_

\_\_\_\_\_

\_\_\_\_\_

(c) Given below are some of the processes involved in producing electricity using a coal fired power station.

<b>A</b>	The coal produces heat	The boiler produces steam	The steam turns the blades of the turbine to make electricity directly
<b>B</b>	The coal produces heat	The heat turns the blades of the turbine	The turbine turns the generator which produces electricity
<b>C</b>	The boiler produces steam	The steam turns the blades of the turbine	The turbine turns the generator which produces electricity
<b>D</b>	The turbine heats the boiler	The boiler produces steam	The steam turns the generator which produces electricity

Which letter **A**, **B**, **C** or **D** gives the correct order of processes? [1 mark]

Answer \_\_\_\_\_



**BLANK PAGE**

**(Questions continue overleaf)**

- 9 Ultrasound can be used to measure the depth of the sea as shown in the diagram below.

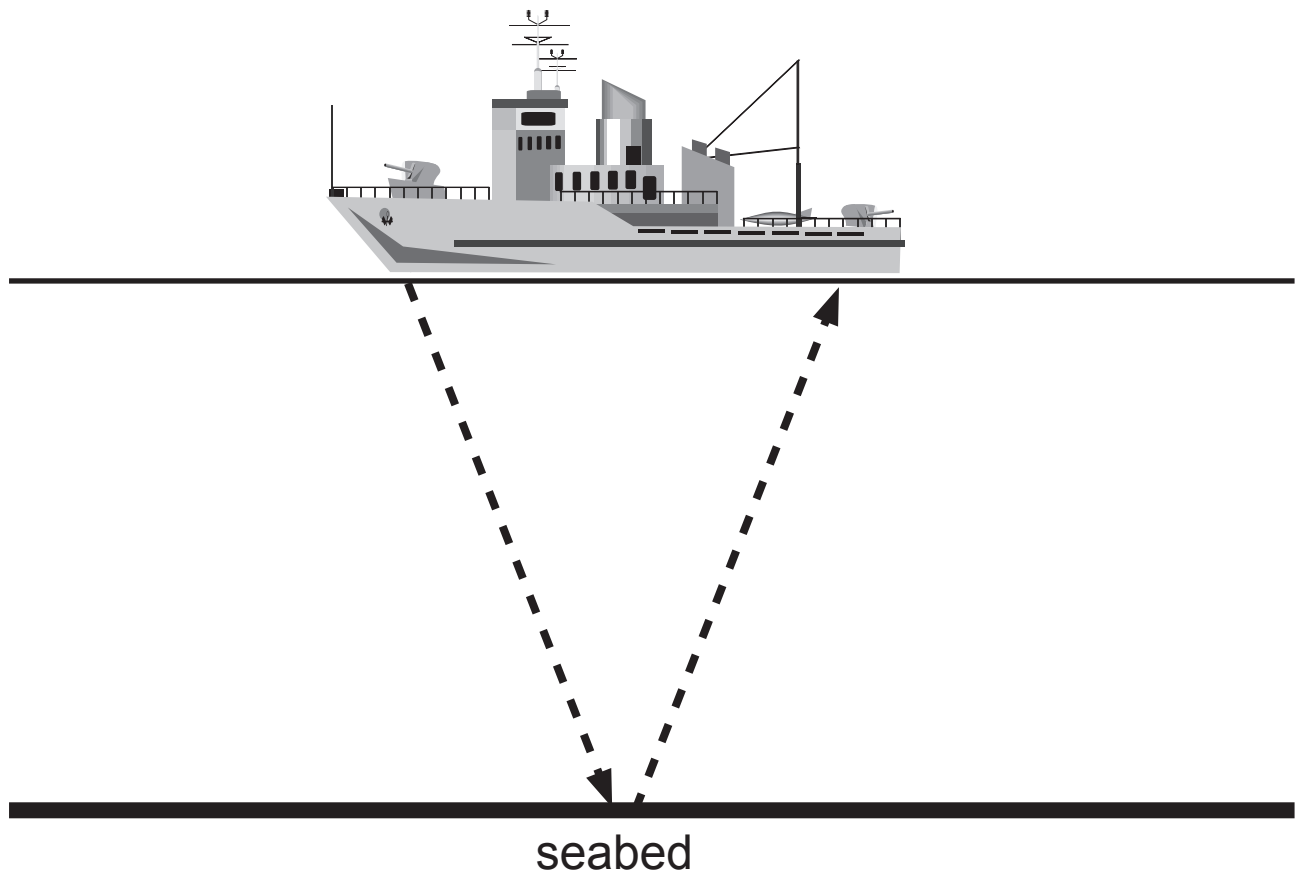

Ultrasound travels at 1500 m/s in water.

- (a) The ship sends out an ultrasound pulse and the echo returns 6 seconds later. [3 marks]

Use the equation:

$$\text{distance} = \text{speed} \times \text{time}$$

to calculate the depth of the water.  
(Show your working out.)

Answer \_\_\_\_\_ m

- (b) How will the captain of the ship know if a shoal of fish swims under the ship? [1 mark]

---

---

---

---

**THIS IS THE END OF THE QUESTION PAPER**

---

## SOURCES

Q2(c) - - - Source: © tridland/iStock/Thinkstock

Q4 - - - - Source: © Gustoimages/Science Photo Library

Q5 - - - - Source: © Victor De Schwanberg/Science Photo Library

Q7 - - - - Source: © NASA/SDO

For Examiner's use only	
Question Number	Marks
1	
2	
3	
4	
5	
6	
7	
8	
9	
<b>Total Marks</b>	

Permission to reproduce all copyright material has been applied for.  
In some cases, efforts to contact copyright holders may have been unsuccessful and CCEA will be happy to rectify any omissions of acknowledgement in future if notified.