



Rewarding Learning

General Certificate of Secondary Education
2012

Centre Number

71

Candidate Number

Science: Single Award (Modular)
Electricity, Waves and Communication
Module 5

Foundation Tier

[GSC51]



WEDNESDAY 14 NOVEMBER 2012, AFTERNOON

TIME

45 minutes.

INSTRUCTIONS TO CANDIDATES

Write your Centre Number and Candidate Number in the spaces provided at the top of this page.
Write your answers in the spaces provided in this question paper.
Answer **all six** questions.

INFORMATION FOR CANDIDATES

The total mark for this paper is 45.
Figures in brackets printed down the right-hand side of pages indicate the marks awarded to each question or part question.

For Examiner's use only	
Question Number	Marks
1	
2	
3	
4	
5	
6	

Total Marks	
--------------------	--



1 (a) Below are three electrical properties and their units.

(i) Use lines to match each property with the correct unit.

Property	Unit	
Voltage	Ohm	
Resistance	Volt	
Current	Ampere	[2]

(ii) Which of the above properties causes a heating effect when electricity flows?
_____ [1]

(iii) Name **two** appliances that use the heating effect of electricity.
Choose from:
fridge toaster radio kettle drill

_____ [2]

Examiner Only	
Marks	Remark

(b) The diagram below shows a three-pin plug.

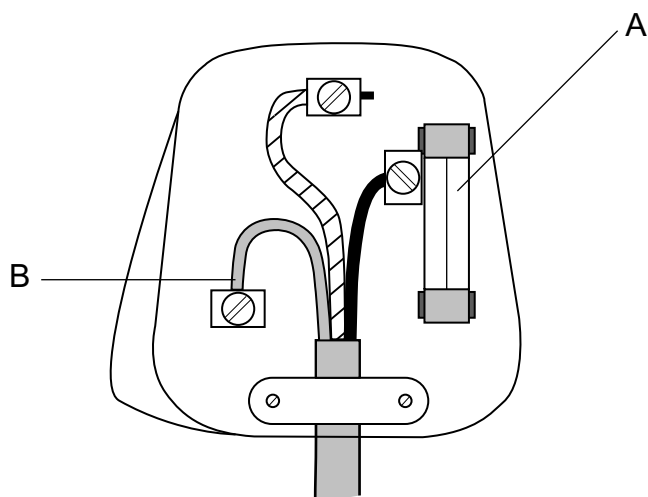

(i) Name the part labelled A. _____ [1]

(ii) Name the wire labelled B. _____ [1]

(iii) What colour is the earth wire?
 _____ and _____ [1]

Examiner Only	
Marks	Remark

2 The diagram below shows the human eye.

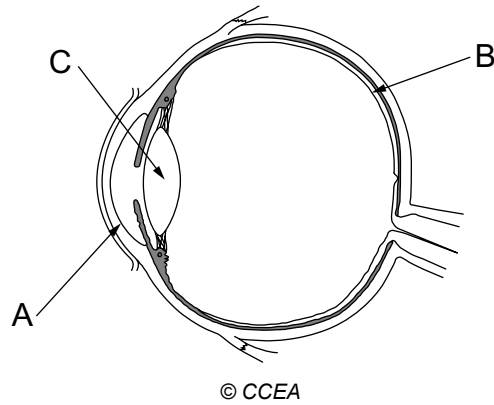

(a) Name the parts labelled A and B on the diagram.

Choose from:

iris retina pupil cornea

A _____

B _____ [2]

(b) (i) Name the type of lens shown as part C.

Circle the correct answer.

contact convex concave [1]

(ii) Describe fully what this type of lens does to parallel rays of light entering the eye.

_____ [2]

Examiner Only	
Marks	Remark

(c) Short sight is a common eyesight problem.

(i) State fully the cause of short sight.

[2]

(ii) Suggest how short sight would affect a person's vision.

[1]

Examiner Only	
Marks	Remark

3 The graph below shows the energy sources used to generate electricity in the UK in the years 2000, 2005 and 2010. It also shows predictions for 2015 and 2020.

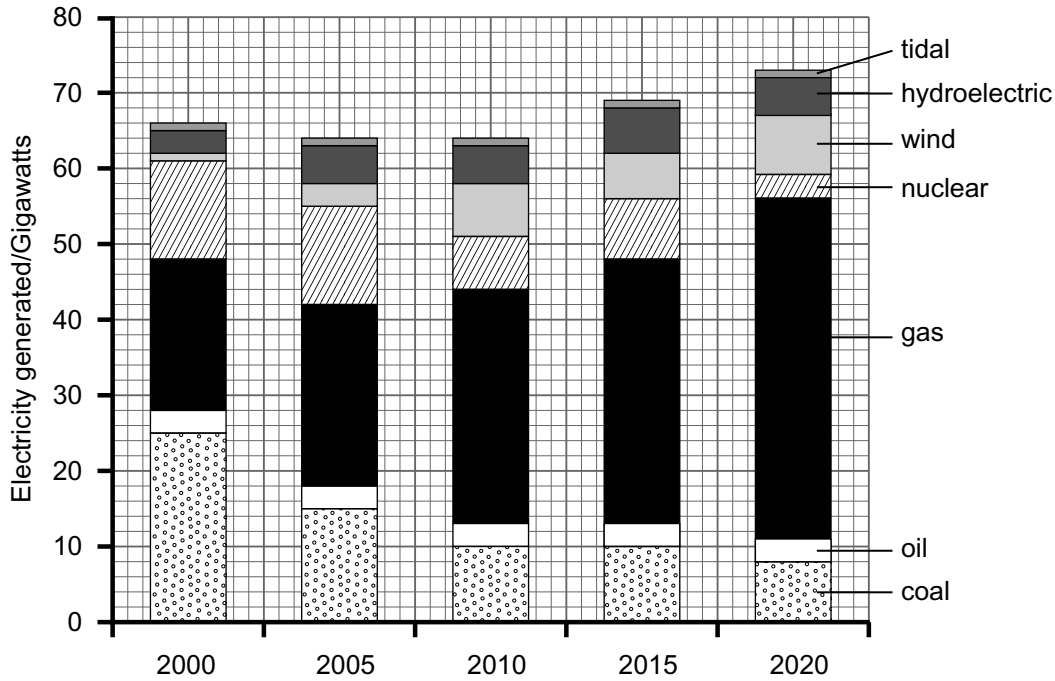

(a) (i) Name **one** energy source that was used more in 2010 than in 2000.

_____ [1]

(ii) Name **one** energy source that was used less in 2010 than in 2000.

_____ [1]

(b) (i) What is meant by the term 'renewable'?

Circle the correct answer.

will run out : **can be used again** : **will not run out** [1]

(ii) Name **one** renewable source shown in the graph.

_____ [1]

Examiner Only	
Marks	Remark

(c) The graph shows that generation of electricity from tidal sources remains almost the same over the 20 years. Suggest **one** reason for this.

[1]

(d) Complete the following sentences.

Choose from:

burn coast extract transport border

All of Northern Ireland's fossil fuel power stations are located close to the _____ . This makes it easier to _____ the fossil fuels. [2]

Examiner Only	
Marks	Remark

- 4 (a) Andrea uses a stretched slinky spring to demonstrate a wave as shown in the diagram.

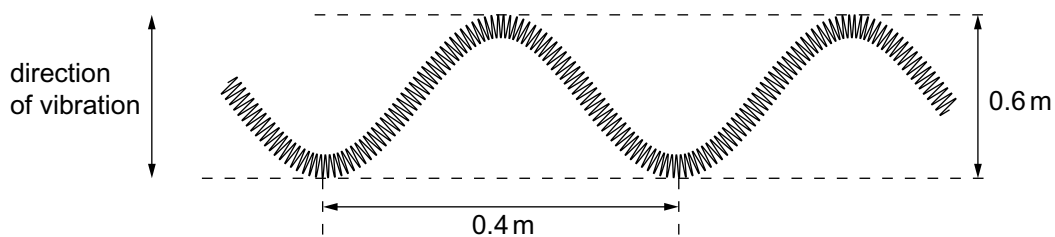

- (i) What type of wave is shown above?

Choose from:

longitudinal **digital** **transverse**

_____ [1]

- (ii) What is the amplitude of this wave?

Choose from:

0.6 m **0.4 m** **0.3 m** **0.8 m**

_____ m [1]

- (iii) What is the wavelength of this wave?

Choose from:

0.6 m **0.4 m** **0.3 m** **0.2 m**

_____ m [1]

Examiner Only	
Marks	Remark

(b) The table below shows the electromagnetic spectrum.

Gamma rays	X-rays	Ultraviolet	Visible light	Infrared	Microwaves	Radio waves
------------	--------	-------------	---------------	----------	------------	-------------

(i) State **one** feature these waves have in common.

_____ [1]

(ii) State **one** feature that is different for each of these waves.

_____ [1]

(iii) Name **one** type of electromagnetic wave used for communication and state how it is used.

Name _____

Use _____

_____ [2]

Examiner Only	
Marks	Remark

- 5 (a) Students set up two experiments to measure the current from two cells. The symbol $\left| \right|$ represents one cell. Their circuit diagrams are shown below but each contains **one** mistake.

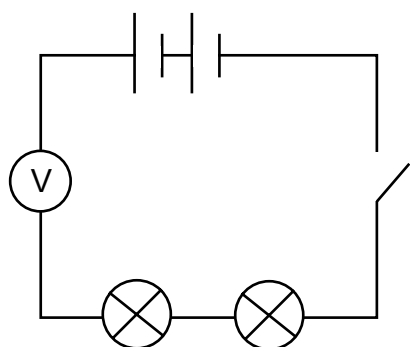

Circuit 1

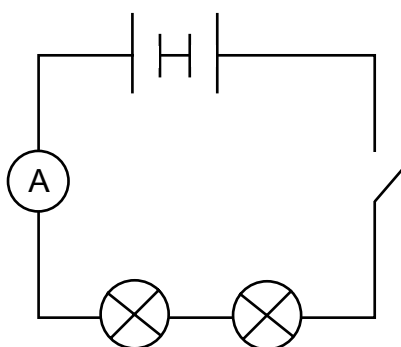

Circuit 2

- (i) Identify the mistake in each circuit.

Circuit 1 _____

Circuit 2 _____

_____ [2]

- (ii) What term is used to describe how the bulbs are connected in both circuits?

_____ [1]

Examiner Only	
Marks	Remark

(b) The students then set up the circuit shown below. Both bulbs are identical.

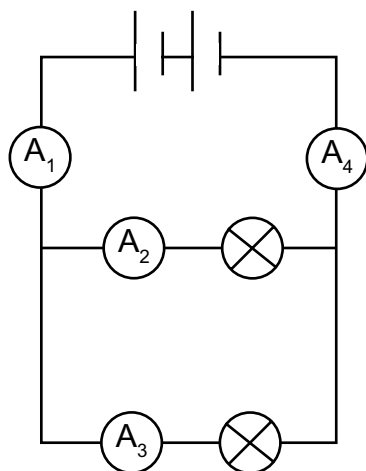

Circuit 3

Ammeter A_1 reads 0.4 amps.

What is the reading on:

ammeter A_3 ? _____ amps

ammeter A_4 ? _____ amps [2]

(c) Describe fully why it is safer to have car headlights (bulbs) connected together as shown in circuit 3 rather than as shown in circuits 1 and 2.

_____ [2]

Examiner Only	
Marks	Remark

6 The diagram below shows a wind turbine used to generate electricity.

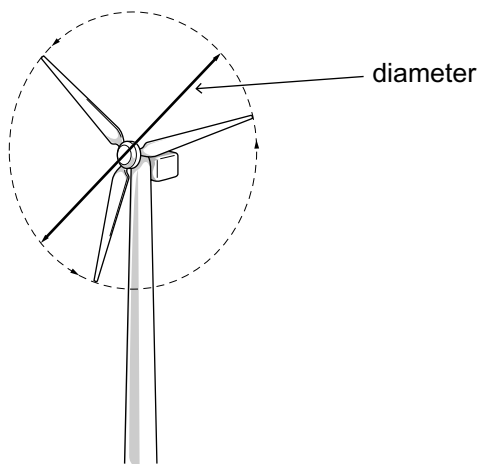

The table below shows how the electrical power output depends on the diameter of the turbine.

Turbine diameter/m	Electrical power output/W
2	60
3	130
4	240
5	370
6	540

(a) Plot a **line graph** of these results on the grid below.

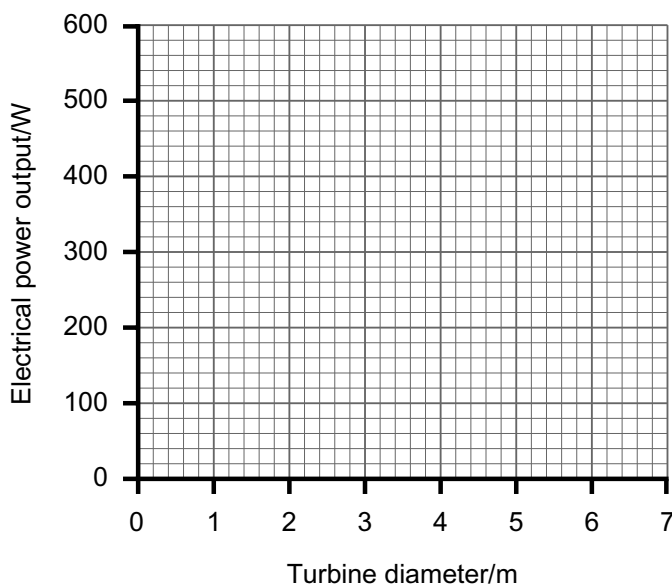

[3]

Examiner Only	
Marks	Remark

Permission to reproduce all copyright material has been applied for.
In some cases, efforts to contact copyright holders may have been unsuccessful and CCEA
will be happy to rectify any omissions of acknowledgement in future if notified.