



Rewarding Learning

General Certificate of Secondary Education  
2016

Centre Number

--	--	--	--	--

Candidate Number

--	--	--	--	--

---

## Double Award Science: Physics

Unit P2

Higher Tier

[GSD62]

MV18

MONDAY 20 JUNE, MORNING

---

### Time

1 hour 15 minutes, plus your additional time allowance.

### Instructions to Candidates

Write your Centre Number and Candidate Number in the spaces provided at the top of this page.

**You must answer the questions in the spaces provided.**

Complete in blue or black ink only. **Do not write with a gel pen.**

Answer **all eight** questions.

### Information for Candidates

The total mark for this paper is 90.

Figures in brackets printed at the end of each question indicate the marks awarded to each question or part question.

Quality of written communication will be assessed in

Question **3(b)** and **5(a)**.

- 1 (a) A graph of displacement against distance for a wave passing through air is given below.

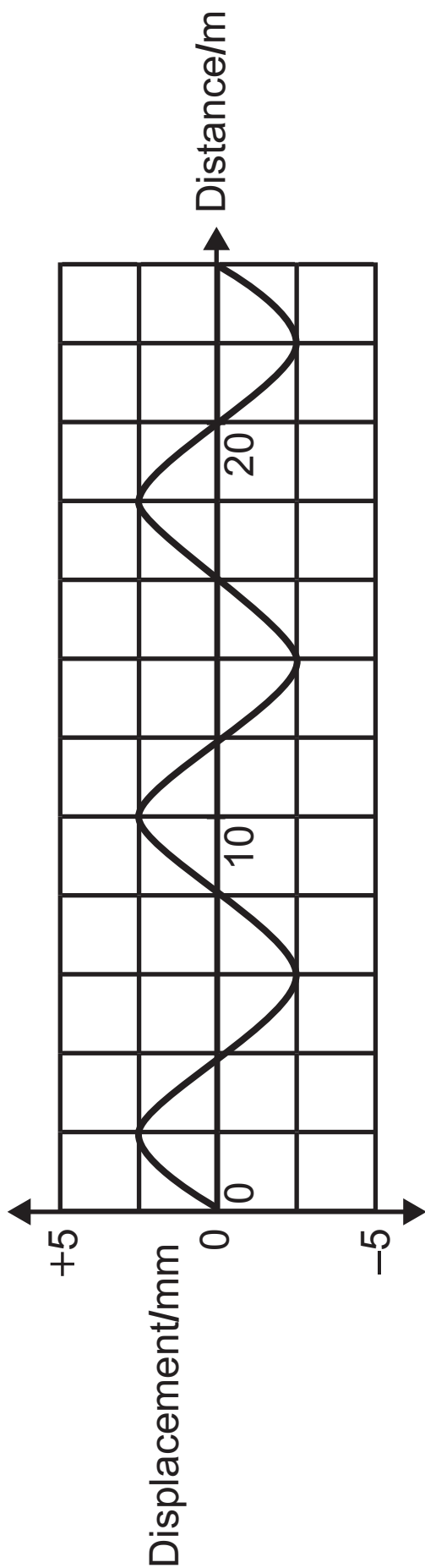

(i) State the amplitude of the waves. [1 mark]

Amplitude = \_\_\_\_\_ mm

(ii) State the wavelength of the waves. [1 mark]

Wavelength = \_\_\_\_\_ m

(b) Radio waves are part of the electromagnetic spectrum. They travel through air at  $3.0 \times 10^8$  m/s.

The frequency of a radio wave is  $2 \times 10^6$  Hz. Calculate its wavelength. [3 marks]

**You are advised to show your working out.**

Wavelength = \_\_\_\_\_ m

(c) State **one** danger of infrared radiation and **one** danger of gamma rays. [2 marks]

Infrared: \_\_\_\_\_

Gamma: \_\_\_\_\_

(d) Describe fully how the particles move in a water wave as it passes a fixed point. [3 marks]

---

---

---

---

(e) When light enters a glass prism it is dispersed into its constituent colours.

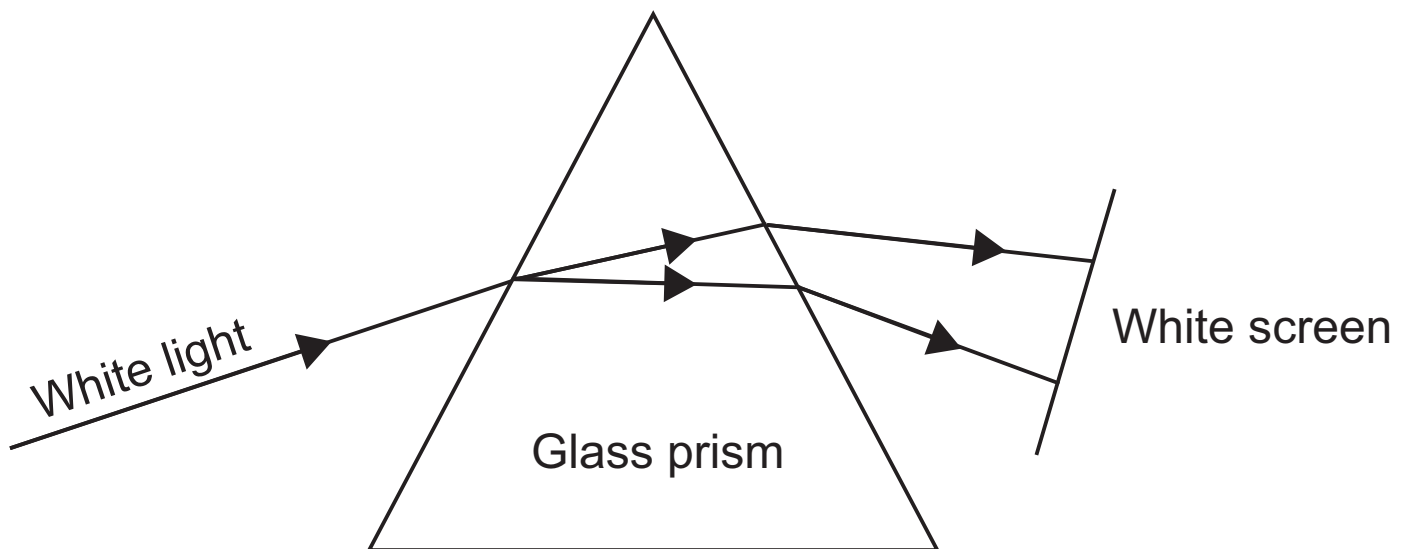

Which colour is refracted the most? [1 mark]

---

2 Jamie looks at an image in a plane mirror.

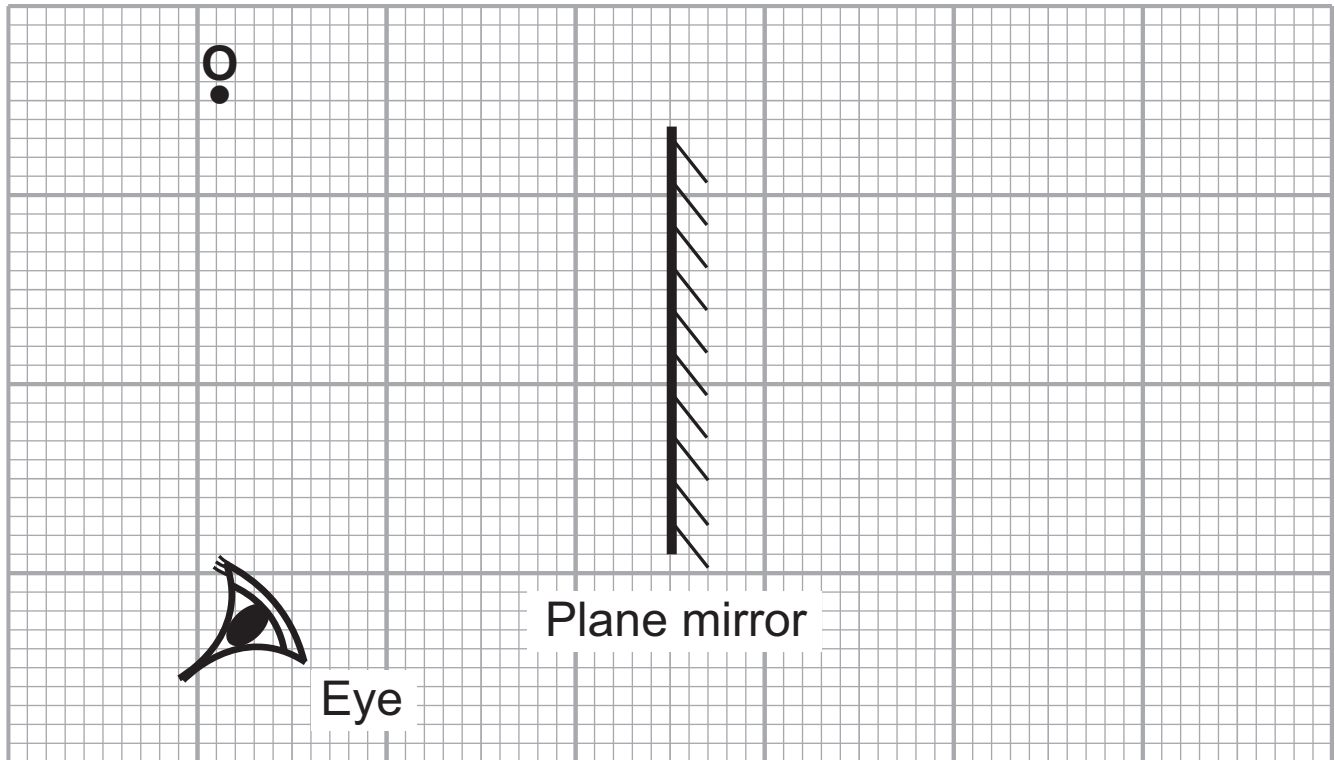

(a) Draw an incident ray and a reflected ray to show how the image of point **O** is viewed by the eye in the mirror. Draw arrows on your rays. [4 marks]

(b) State **three** properties of the image in a plane mirror. [3 marks]

1. \_\_\_\_\_
2. \_\_\_\_\_
3. \_\_\_\_\_

Jamie sends a ray of light through a glass block.

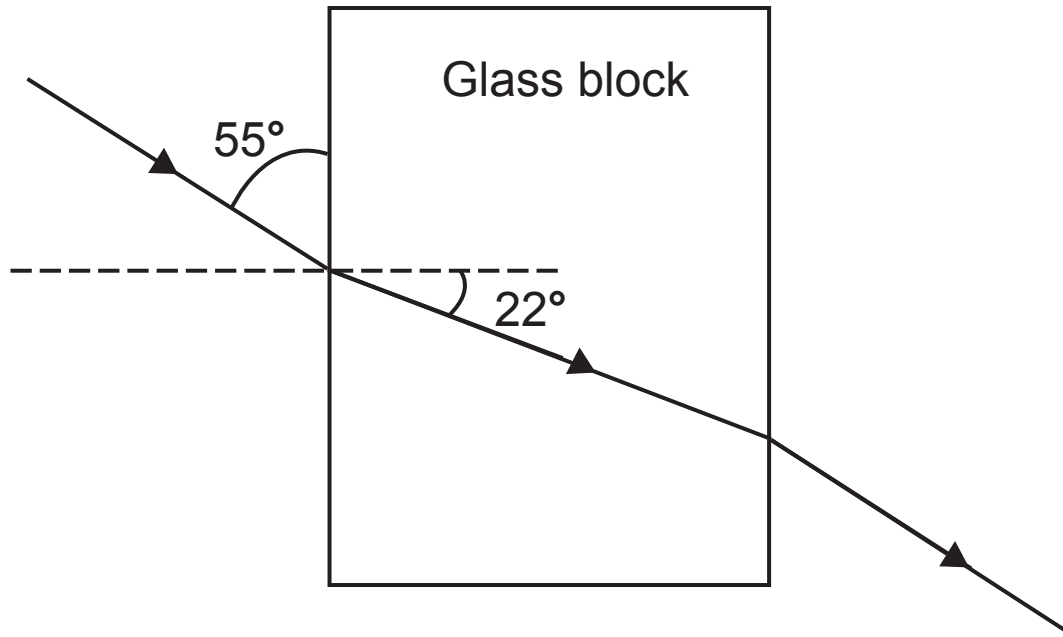

(c) (i) What is the angle of incidence? [1 mark]

\_\_\_\_\_°

(ii) What is the angle of refraction of the light ray in the glass block? [1 mark]

\_\_\_\_\_°

(d) Water waves pass from deep water to shallow water in a ripple tank.

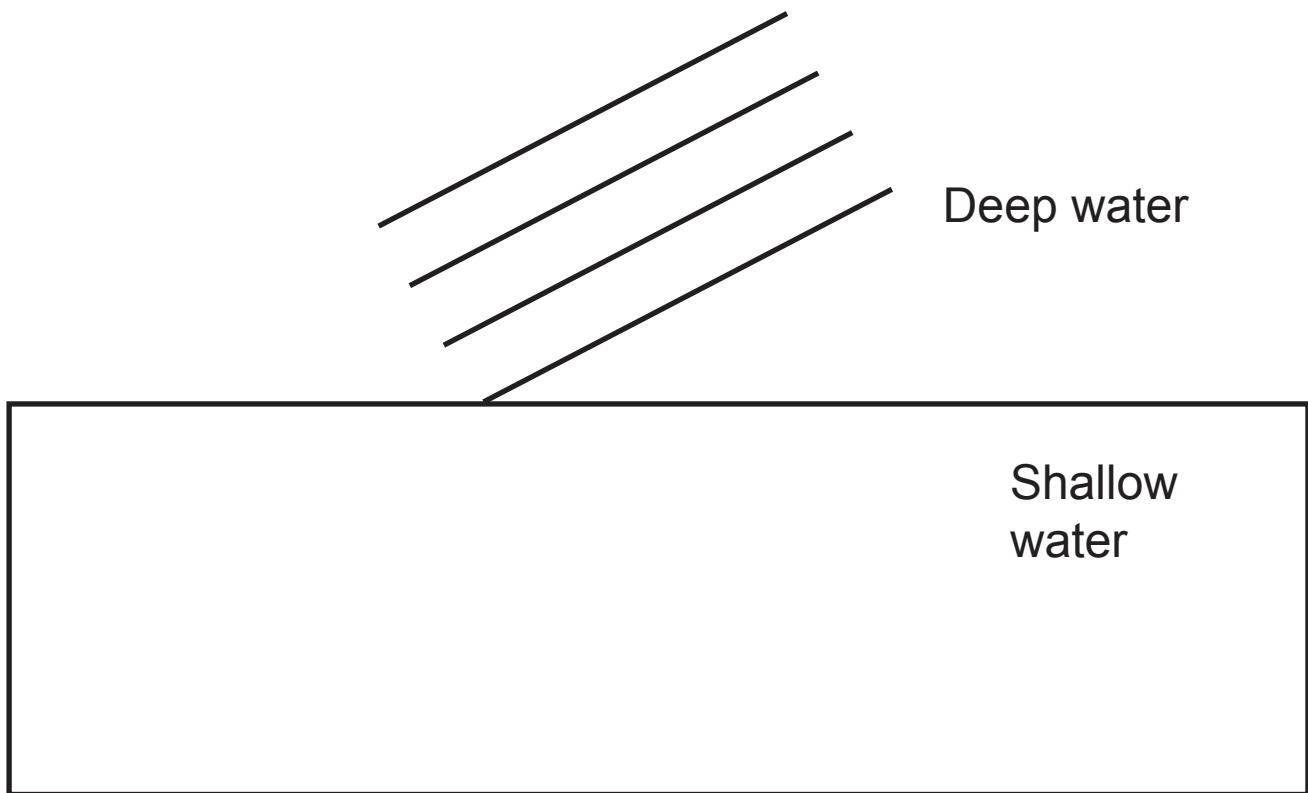

(i) Draw an arrow to indicate the direction of travel of the waves in the deep water.

Your arrow should end at the boundary between deep and shallow water. [1 mark]

(ii) Draw an arrow to show the direction of travel of the water waves in the shallow water.

Your arrow should begin at the point where the arrow drawn in (i) ends. [1 mark]

**(iii)** What happens, if anything, to the speed of the waves as they enter the shallow water? [1 mark]

---

**(iv)** What, if anything, happens to the wavelength of the waves as they enter the shallow water? [1 mark]

---



**3** The diagram shows a cross section of the Earth.

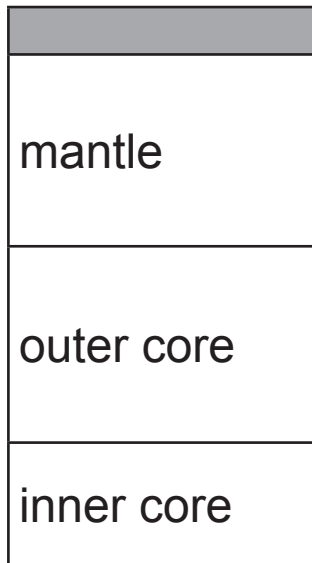

**(a) (i)** Name a section which is completely liquid.  
[1 mark]

Answer \_\_\_\_\_

**(ii)** Name a section which is part solid and part liquid.  
[1 mark]

Answer \_\_\_\_\_

**(iii)** Name the shaded layer in the diagram above.  
[1 mark]

Answer \_\_\_\_\_



**BLANK PAGE**

**(Questions continue overleaf)**

- 4 Temperature is measured in degrees Celsius ( $^{\circ}\text{C}$ ).  
An older temperature scale is called Fahrenheit ( $^{\circ}\text{F}$ ).

The table below gives temperatures in  $^{\circ}\text{C}$  and the corresponding temperatures in  $^{\circ}\text{F}$ .

Temp/ $^{\circ}\text{C}$	0	20	40	60	80	100
Temp/ $^{\circ}\text{F}$	32	68	104	140	176	212

The two temperature scales are related.

You are asked to plot a graph opposite of temperature in Fahrenheit against temperature in Celsius.

- (i) Choose a suitable scale for the horizontal axis and label it. [2 marks]
- (ii) Plot the points on the grid. [2 marks]
- (iii) Draw the best fit line. [1 mark]

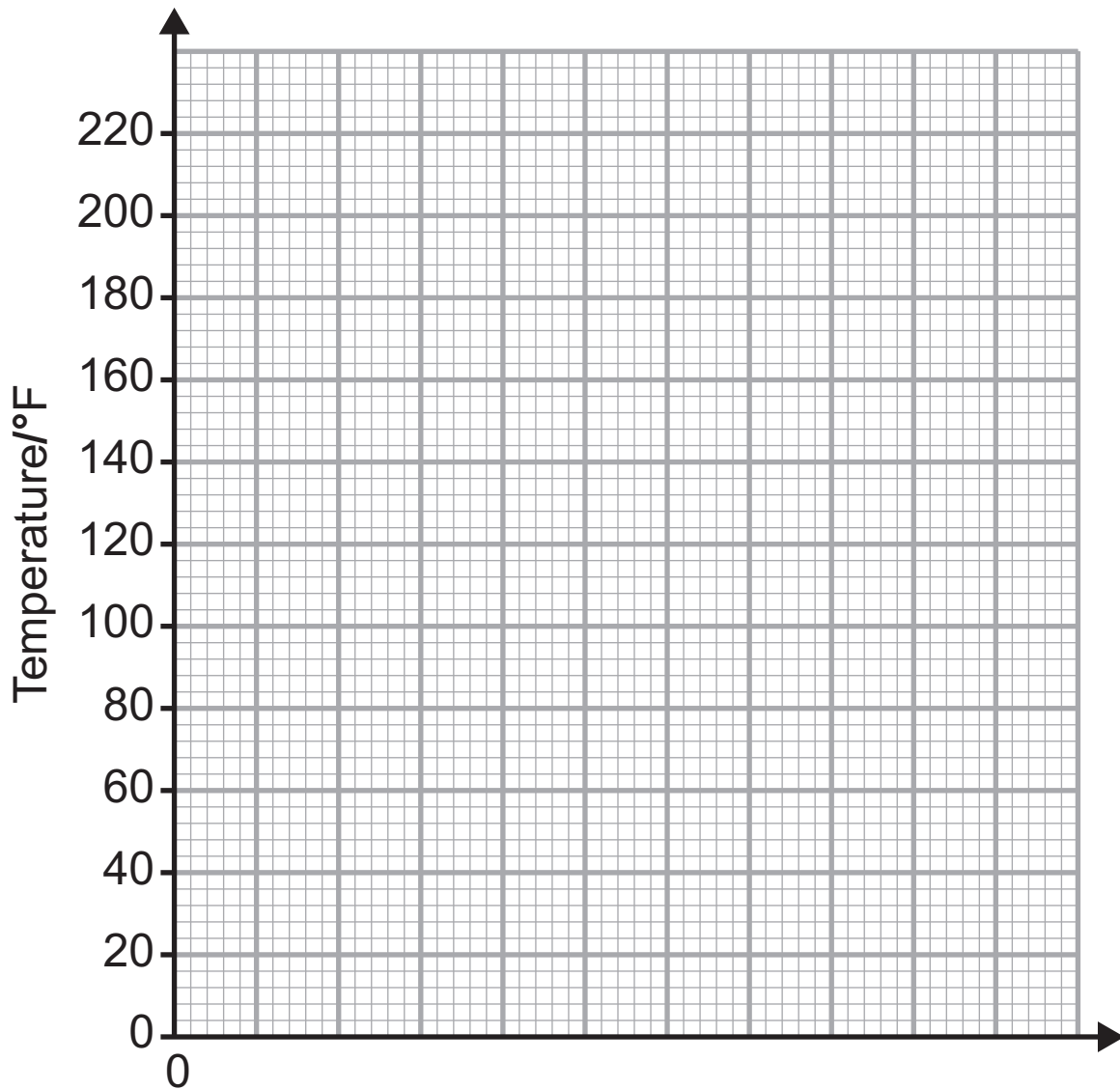

Use your graph to answer the following questions:

(iv) The intercept on the vertical axis gives the temperature of melting ice.

What is this temperature in °C? [1 mark]

Temperature of melting ice \_\_\_\_\_ °C

(v) A type of alcohol boils at 194 °F. What is this temperature in °C? [1 mark]

\_\_\_\_\_ °C

**(vi)** Calculate the gradient of your graph. [3 marks]

Remember to include the unit. [1 mark]

**You are advised to show your working out.**

Gradient = \_\_\_\_\_

Unit = \_\_\_\_\_

**(vii)** Does your graph show direct proportion?

\_\_\_\_\_

Give a reason for your answer. [1 mark]

\_\_\_\_\_

- 5 A plastic rod **A** is negatively charged. It is brought close to, but not touching, a second uncharged plastic rod, **B**.

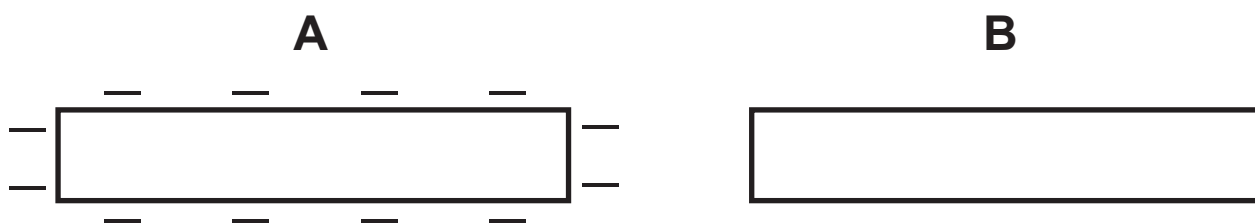

- (a) Explain fully in terms of charges why the rods attract each other. [6 marks]

**In your answer you must:**

- describe how rod **A** may have become charged;
- describe, in terms of charges, why the rods attract each other.

**In this part of the question you will be assessed on your written communication skills including the use of specialist scientific terms.**

---

---

---

---

---

---

---

---

---

---

---

---

---

---



Lightning is a sudden flow of electricity.



(b) A flash of lightning lasts  $2 \times 10^{-4}$ s during which 15C of charge is transferred from a charged cloud to earth.

Calculate the average current. [3 marks]

**You are advised to show your working out.**

Current = \_\_\_\_\_ A

- 6 Julie wants to find out how the resistance of a piece of resistance wire depends on its length. She can vary the length of the wire.

She sets up the circuit shown to get enough readings to plot a graph.

M1 and M2 represent electrical meters.

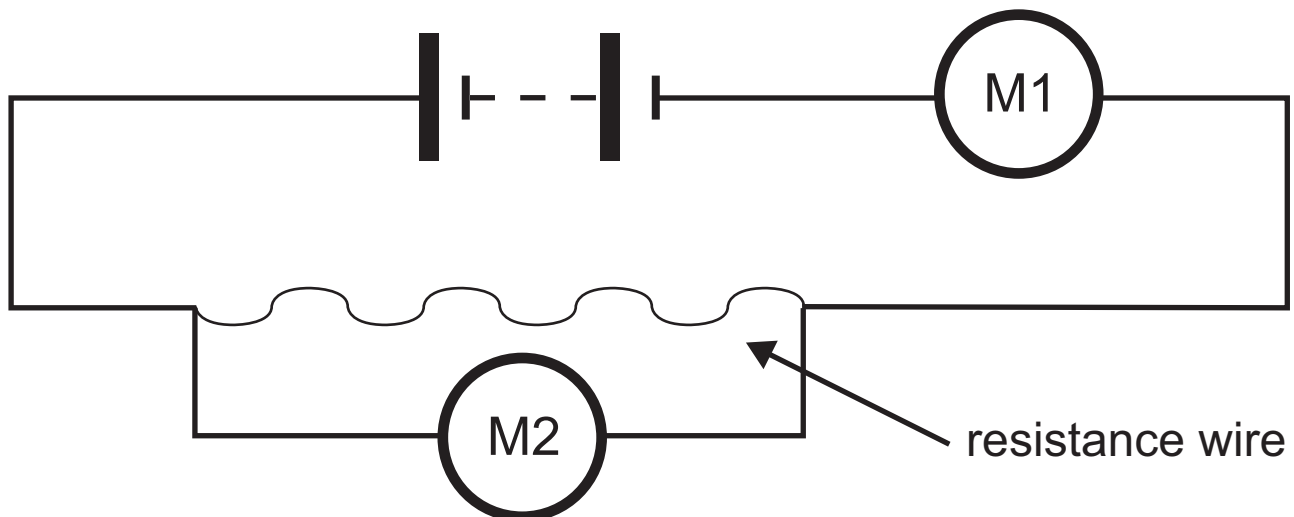

- (i) What does meter M1 measure?

M1 measures \_\_\_\_\_

What does meter M2 measure? [2 marks]

M2 measures \_\_\_\_\_

- (ii) What additional component should Julie have included in the circuit? [1 mark]

\_\_\_\_\_

(iii) Why should she have included this component?  
[1 mark]

---

(iv) Name **two** factors that must be kept constant during the experiment to make the test fair. [2 marks]

1. \_\_\_\_\_

2. \_\_\_\_\_

(v) Which of the following graphs, **A**, **B** or **C**, correctly shows how the resistance  $R$  changes with the length  $\ell$ ?

Put a circle around the correct letter below. [1 mark]

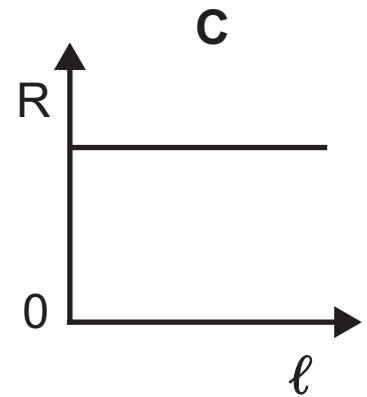
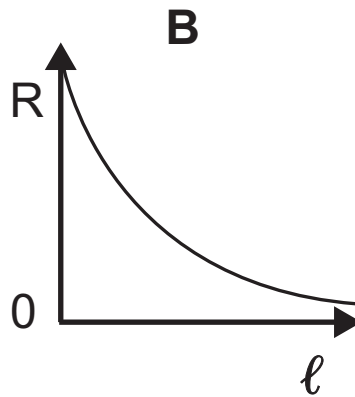
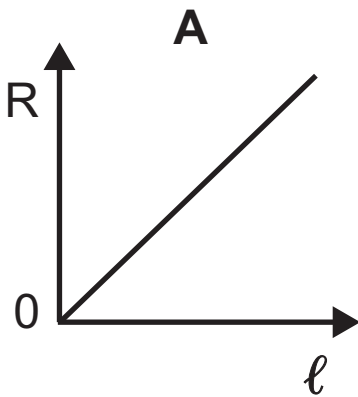

(vi) Julie has a piece of resistance wire. It is 90 cm long and has a resistance of  $6\Omega$ . However she only needs a resistance of  $5\Omega$ . What length of resistance wire will she use? [3 marks]

**You are advised to show your working out.**

Length = \_\_\_\_\_ cm

7 Four resistors are arranged in the following pattern.

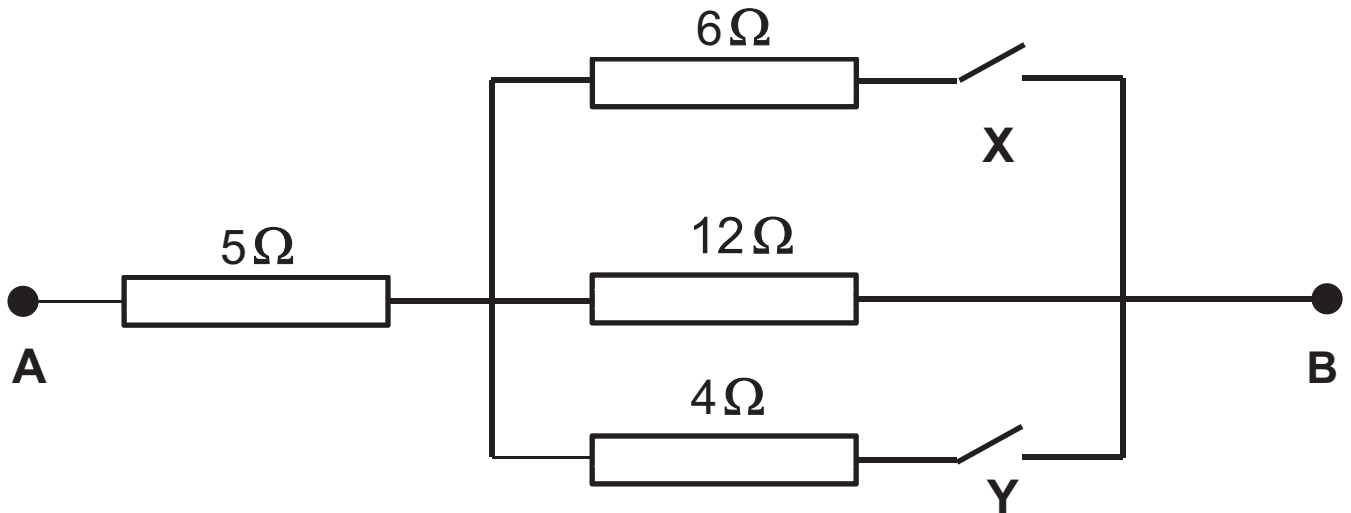

(a) (i) Complete the table to show the total resistance between **A** and **B** for the different switch settings.  
[2 marks]

Switch X	Switch Y	Resistance between A and B/ $\Omega$
Open	Open	
Closed	Open	

(ii) Calculate the total resistance between **A** and **B** when both switches are closed. [4 marks]

**You are advised to show your working out.**

Resistance = \_\_\_\_\_  $\Omega$

A current of 480 mA flows through the  $5\Omega$  resistor in the circuit below.

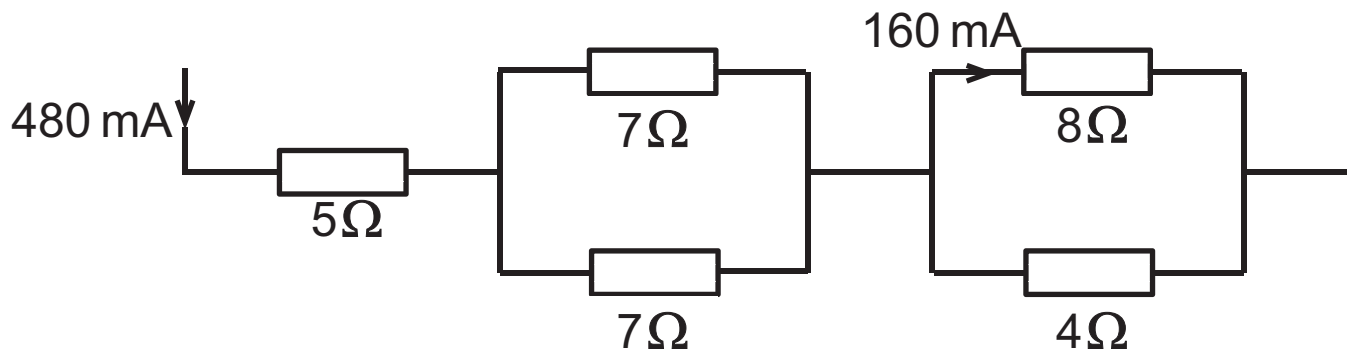

(b) Complete the table to show the currents flowing through the different resistors. [2 marks]

Resistor	Current flowing/mA
$5\Omega$	480
$7\Omega$	
$4\Omega$	

- (c) What is the voltage across the  $5\Omega$  resistor when a current of 480 mA flows through it? [4 marks]

**You are advised to show your working out.**

Voltage = \_\_\_\_\_ V

- (d) What is the power developed in a different resistor if the current through it is 0.02A when the voltage across it is 6.0V? [4 marks]

Remember to include the unit.

**You are advised to show your working out.**

Power = \_\_\_\_\_



- 8 The diagram below shows a coil, a sensitive centre-zero ammeter and a bar magnet.

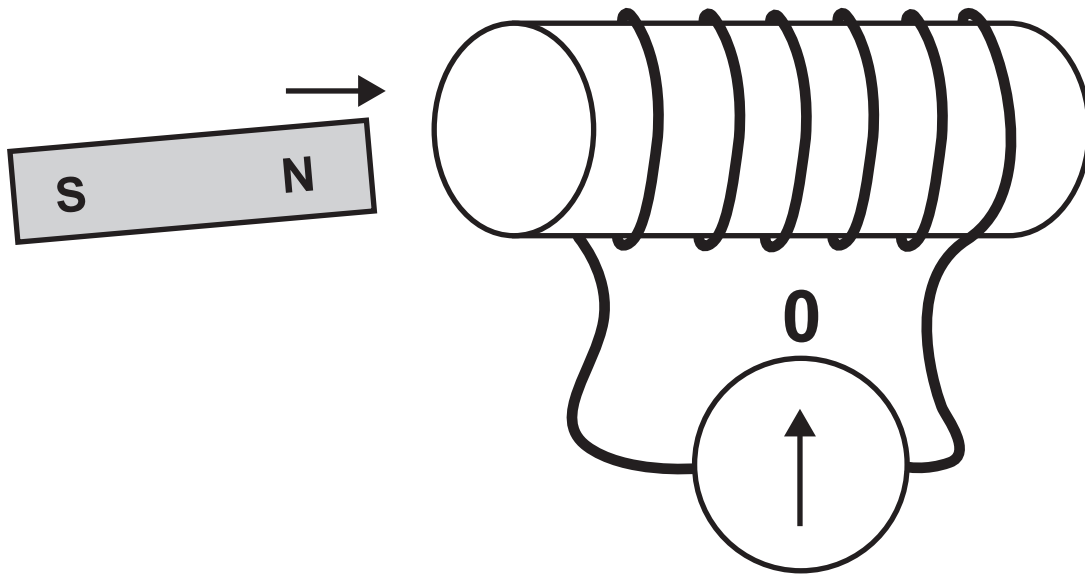

(a) When the North pole of the bar magnet is moved into the coil the ammeter gives a momentary deflection to the left.

- (i) What, if anything, is observed on the centre-zero ammeter when the magnet is at rest inside the coil?  
[1 mark]

---

- (ii) The magnet is now withdrawn from the coil. What, if anything, is observed on the centre-zero ammeter as the magnet is moved away from the coil?  
[2 marks]

---

---

- (b)** The input voltage to a transformer is 240 V.  
There are 2000 turns on the primary coil and 100 turns on the secondary coil.

Calculate the output voltage of the transformer.  
[3 marks]

**You are advised to show your working out.**

Output voltage = \_\_\_\_\_ V

- (c)** Transformers play an important role in the distribution of electricity.

- (i)** Where is the step-up transformer used? [1 mark]

---

- (ii)** Explain fully its use in the transmission system.  
[3 marks]

---

---

---

---

**THIS IS THE END OF THE QUESTION PAPER**

---

## SOURCES

Q2 - - - - © Principal Examiner

Q5 - - - - © Balazs Kovacs / iStock / Thinkstock

**DO NOT WRITE ON THIS PAGE**

For Examiner's use only	
Question Number	Marks
1	
2	
3	
4	
5	
6	
7	
8	

<b>Total Marks</b>	
--------------------	--

Examiner Number

Permission to reproduce all copyright material has been applied for.  
In some cases, efforts to contact copyright holders may have been unsuccessful and CCEA will be happy to rectify any omissions of acknowledgement in future if notified.