



*Rewarding Learning*

General Certificate of Secondary Education  
2015–2016

Centre Number

--	--	--	--	--

Candidate Number

--	--	--	--	--

---

## Double Award Science: Physics

Unit P1  
Higher Tier

[GSD32]

FRIDAY 13 NOVEMBER 2015, MORNING

---

MV18

### Time

1 hour, plus your additional time allowance.

### Instructions to Candidates

Write your Centre Number and Candidate Number in the spaces provided at the top of this page.

Write your answers in the spaces provided in this question paper.  
Answer **all nine** questions.

### Information for Candidates

The total mark for this paper is 70.

Figures in brackets printed at the end of each question indicate the marks awarded to each question or part question.

Quality of written communication will be assessed in Questions **2(a)** and **7**.

- 1 A pendulum consists of a mass hanging on a string. When the pendulum has a length (L), the time (T) for one complete back and forth swing of the mass is given by the relationship:

$$T^2 = kL \quad \text{Equation 1.1}$$

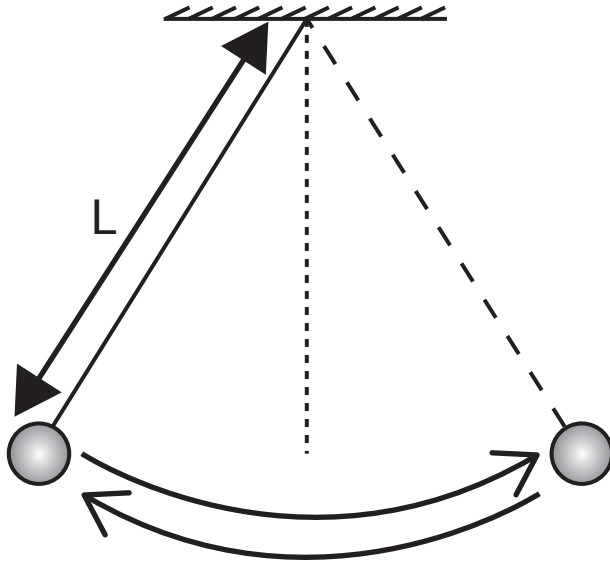

To test this relationship the following results were recorded.

L/m	0.0	0.2	0.4	0.6	0.8	1.0
T/s	0.0	0.90	1.27	1.55	1.79	2.00
T <sup>2</sup> /s <sup>2</sup>			1.6			

- (i) Complete the table by entering the values for T<sup>2</sup>, to 1 decimal place.

One has been done for you. [2 marks]

You are asked to plot a graph of T<sup>2</sup> against L.

- (ii) Choose a suitable scale for the vertical axis and label it. [2 marks]

(iii) Plot the points on the grid. [2 marks]

(iv) Draw a line of best fit. [1 mark]

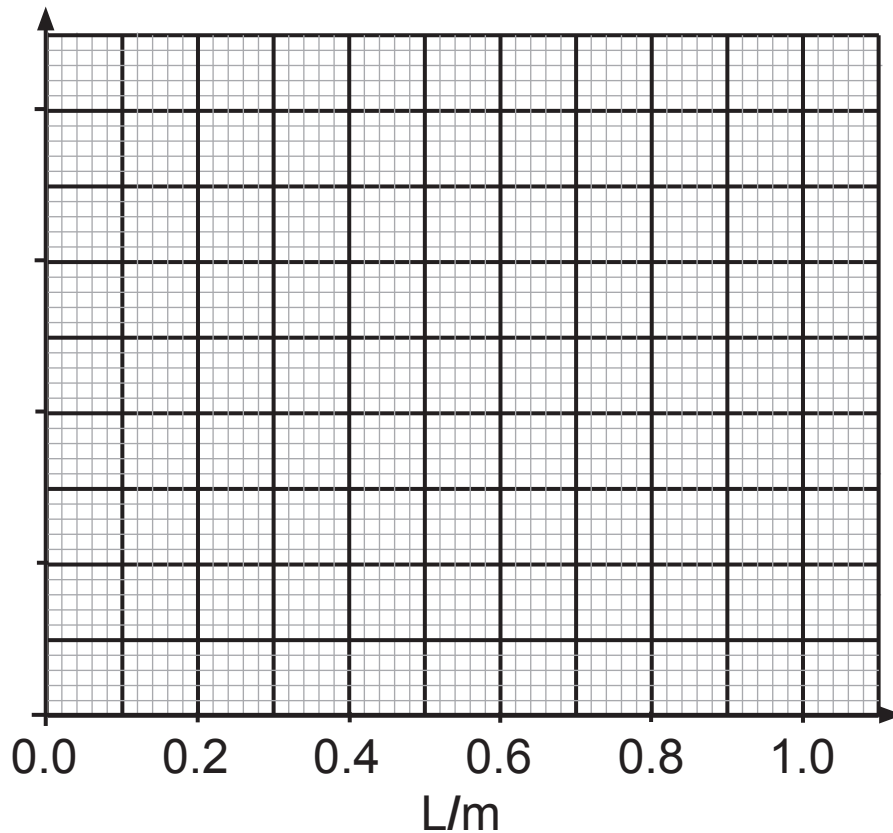

(v) Does your graph support the theory described by **Equation 1.1**?

Yes / No      Circle your choice.

Explain your answer. [2 marks]

---

---

(vi) Find the value of  $k$  from your graph. [2 marks]

$$k = \frac{\quad}{3} \text{ s}^2/\text{m}$$

- 2 (a) A force, called the centripetal force, causes a body to move in a circle. Give an account of the factors that the centripetal force depends on and how it depends on them. [6 marks]

Your account must:

- state the direction of the centripetal force;
- state the three factors affecting the size of the centripetal force;
- state how the centripetal force depends on each of these three factors.

**You will be assessed on your written communication skills including the use of specialist scientific terms.**

---

---

---

---

---

---

---

---

---

---

---

---

---

---

---

---

---

---

---

---

---

---

---

---

**(b)** A body of weight 2 N moves in a circle. At a given instant its velocity is 3 m/s.

Calculate its momentum in kg m/s. [4 marks]

**You are advised to show your working out.**

Momentum = \_\_\_\_\_ kg m/s

3 The symbol for uranium-238 is  ${}_{92}^{238}\text{U}$ .

(a) (i) How many protons does a nucleus of uranium-238 contain? [1 mark]

Number of protons = \_\_\_\_\_

(ii) How many neutrons does a nucleus of uranium-238 contain? [1 mark]

Number of neutrons = \_\_\_\_\_

(b) An **isotope** of sodium is **radioactive**.

Explain fully what is meant by the words in bold.

**Isotope** [2 marks]

---

---

**Radioactive** [2 marks]

---

---

(c) Thirty hours after a sample of radioactive sodium had been prepared, only 25% of it remained.

Calculate the half-life of this isotope. [3 marks]

**You are advised to show your working out.**

Half-life = \_\_\_\_\_ hours

- 4 A liquid has a density of  $0.8 \text{ g/cm}^3$ . 576 g of the liquid is poured into a glass container, the base of which measures 6 cm by 5 cm.

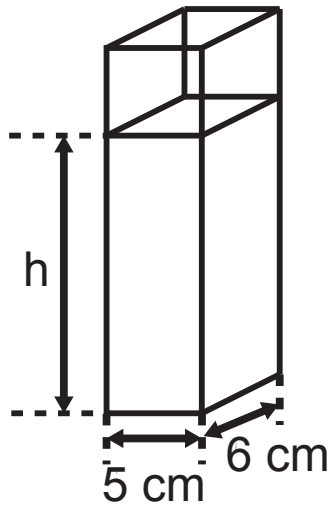

- (a) (i) Calculate the volume of liquid in the container.  
[3 marks]

**You are advised to show your working out.**

Volume = \_\_\_\_\_  $\text{cm}^3$



(ii) Use your answer to (a)(i) to find the height,  $h$ , of the liquid. [2 marks]

**You are advised to show your working out.**

Height = \_\_\_\_\_ cm

(b) How does the density of the glass compare with the density of the liquid?

Tick (✓) the correct box below.

Glass has a smaller density

Glass has a larger density

Glass has the same density

Use the kinetic theory to explain your choice.

[2 marks]

---

---

---

- 5 Gavin is interested in how quickly a glass bead falls through water.

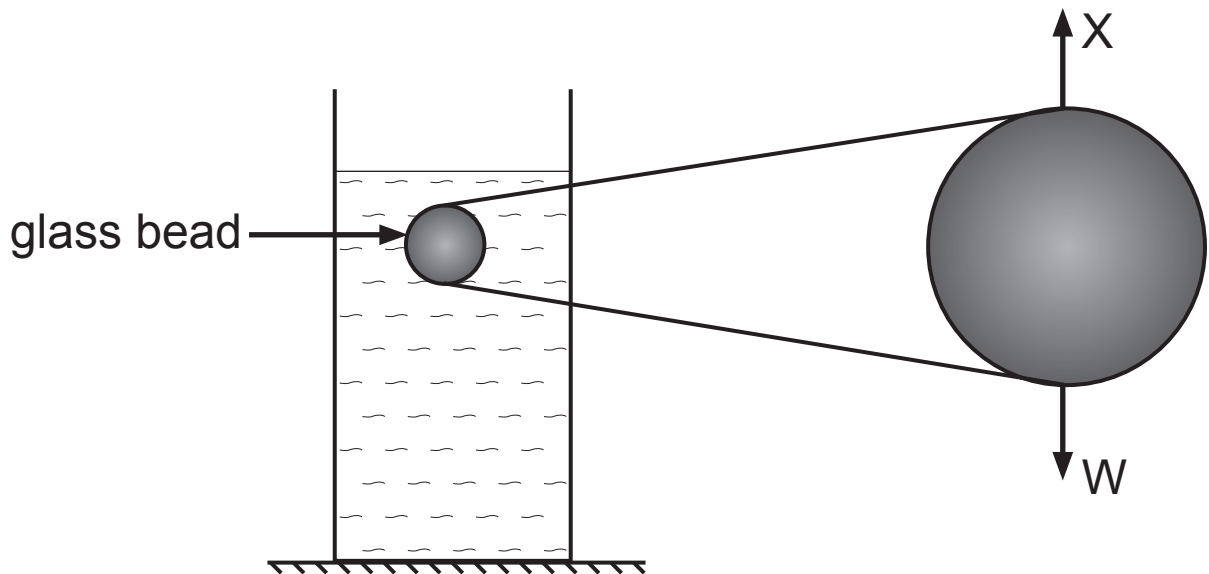

- (a) (i) Two forces,  $W$  and  $X$ , act on the glass bead as it falls.  $W$  is the weight. What is the name of the other force  $X$ ? [1 mark]

$X$  is \_\_\_\_\_

Gavin plots a velocity–time graph of the glass bead’s motion from entry into the water until it hits the bottom of the container.

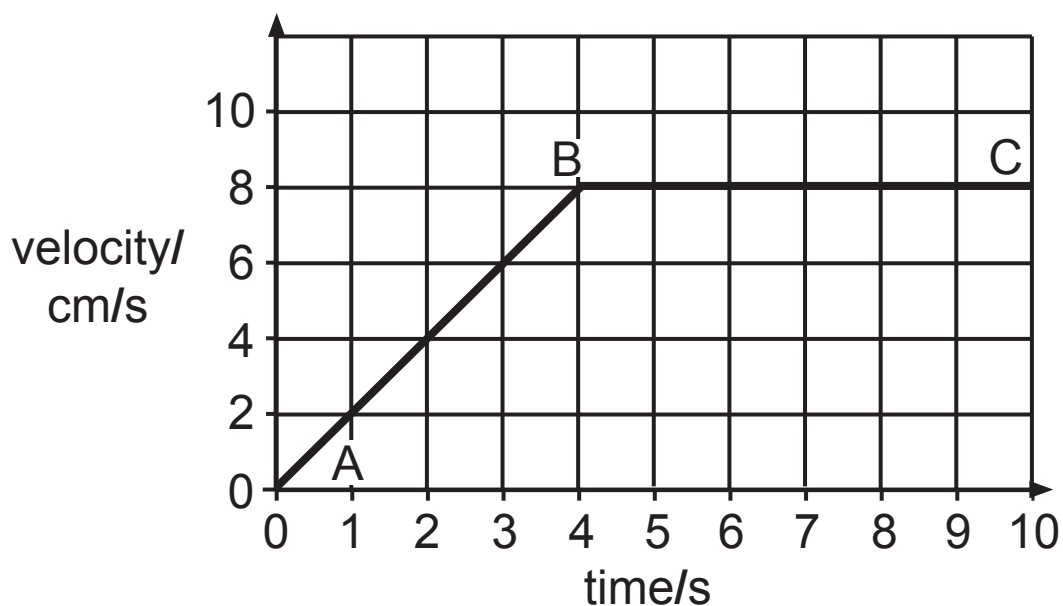

- (ii) How do the sizes of these forces compare during the regions AB and BC? Give your answer by ticking (✓) the correct box in each case. [2 marks]

**During AB,**

W is less than X.

the two forces are equal.

X is less than W.

**During BC,**

W is less than X.

the two forces are equal.

X is less than W.

- (b) (i) Use the graph to calculate the distance the glass bead falls in 10 seconds. [4 marks]

**You are advised to show your working out.**

Distance = \_\_\_\_\_ cm

- (ii) Find the acceleration of the glass bead during the first four seconds of its fall. [3 marks]

**You are advised to show your working out.**

Acceleration = \_\_\_\_\_  $\text{cm/s}^2$

- 6 The table below contains a number of statements. For each statement insert one tick (✓). [6 marks]

Tick **T** if the statement is true.

Tick **F** if the statement is false.

Tick **I** if it is impossible to decide.

	<b>T</b>	<b>F</b>	<b>I</b>
Atomic number is given the symbol A.			
In a neutral atom the number of protons equals the number of electrons.			
Beta particles are negatively charged electrons.			
An alpha particle is a helium atom.			
A beta particle comes from the nucleus of an atom.			
Radiation is stopped by a few mm of aluminium.			

**7 Describe an experiment to verify the Principle of Moments.**  
[6 marks]

In your description you should:

- describe how you would carry out the experiment;
- state the measurements you would make;
- state how you would use these measurements to verify the Principle of Moments.

**You will be assessed on your written communication skills including the use of specialist scientific terms.**

The following diagram may help you.

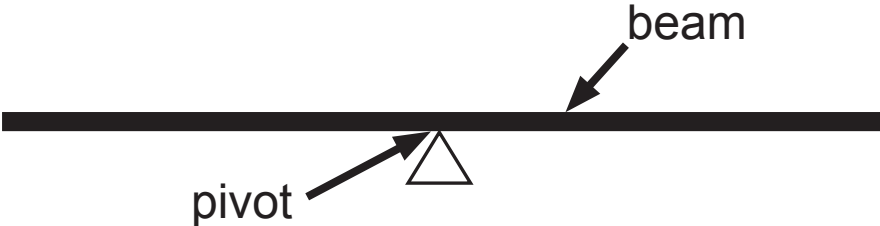

---



---



---



---



---



---



---



---



---



---



---



---

---

---

---

---

---

**BLANK PAGE**



8 An acrobat grips a rope loosely as he slides down it.



A force acting on the acrobat leads to heat energy being produced.

- (a) In the box draw an arrow to indicate the direction of this force. [1 mark]
- (b) The acrobat has a mass of 70 kg and slides down the rope with an acceleration of  $4 \text{ m/s}^2$ . Calculate the value of the force referred to in part (a). [4 marks]

**You are advised to show your working out.**

Force = \_\_\_\_\_ N

- 9 Jim and his cycle have a total mass of 80 kg. At the top of a hill they have a potential energy of 4640 J. Jim freewheels **from rest** down the hill and part of the way up a second hill. At point B he has a speed of 6 m/s.

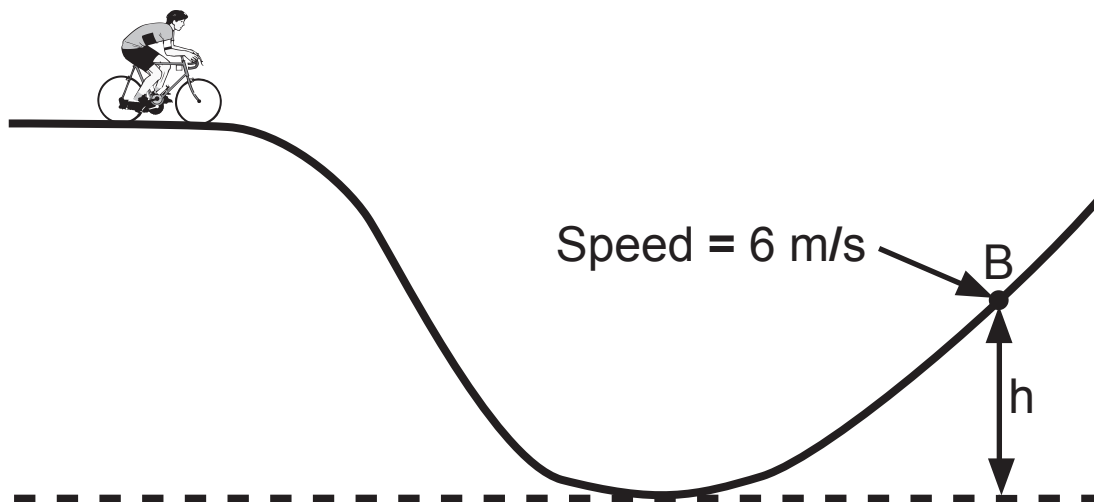

- (i) Calculate the kinetic energy of Jim and his cycle at point B. [3 marks]

**You are advised to show your working out.**

Kinetic energy = \_\_\_\_\_ J

- (ii) Use the Principle of Conservation of Energy to calculate the height,  $h$ . Assume no energy losses.  
[3 marks]

**You are advised to show your working out.**

Height = \_\_\_\_\_ m

---

**THIS IS THE END OF THE QUESTION PAPER**

---

**Sources:**

Q 8, Pg 17, Image of a man climbing a rope, © Lunamarina/iStock/Thinkstock

For Examiner's use only	
Question Number	Marks
1	
2	
3	
4	
5	
6	
7	
8	
9	
<b>Total Marks</b>	

Permission to reproduce all copyright material has been applied for. In some cases, efforts to contact copyright holders may have been unsuccessful and CCEA will be happy to rectify any omissions of acknowledgement in future if notified.