



Rewarding Learning

General Certificate of Secondary Education
2013–2014

Centre Number

71	
----	--

Candidate Number

--

Double Award Science: Physics

Unit P1

Higher Tier

[GSD32]



WEDNESDAY 26 FEBRUARY 2014, MORNING

TIME

1 hour.

INSTRUCTIONS TO CANDIDATES

Write your Centre Number and Candidate Number in the spaces provided at the top of this page.
Write your answers in the spaces provided in this question paper.
Answer **all eight** questions.

INFORMATION FOR CANDIDATES

The total mark for this paper is 70.
Figures in brackets printed down the right-hand side of pages indicate the marks awarded to each question or part question.
Quality of written communication will be assessed in Questions **1(a)** and **6(c)**.

For Examiner's use only	
Question Number	Marks
1	
2	
3	
4	
5	
6	
7	
8	

Total Marks	
--------------------	--

1 (a) You are given a number of steel objects. Describe an experiment you would carry out to find the density of steel.



© Les Cunliffe/iStock/Thinkstock

Your answer should include,

- the apparatus used,
- the readings you take,
- how the readings are used.

In this question you will be assessed on your written communication skills including the use of specialist scientific terms.

[6]

Examiner Only	
Marks	Remark
○	○

- 2 A student investigates how the extension of a spiral spring depends on the weight hung on it.

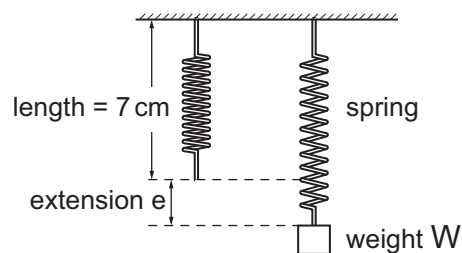

The equation connecting the extension, e and weight, W is given by:

$$e = kW$$

The table shows some of the results of the investigation.

W in N	0.5	1.0	1.5	2.0	2.5
e in cm	2	4	6	8	10

You are asked to plot a graph of e against W .

- (i) Choose a suitable scale for W and label the horizontal axis. [2]

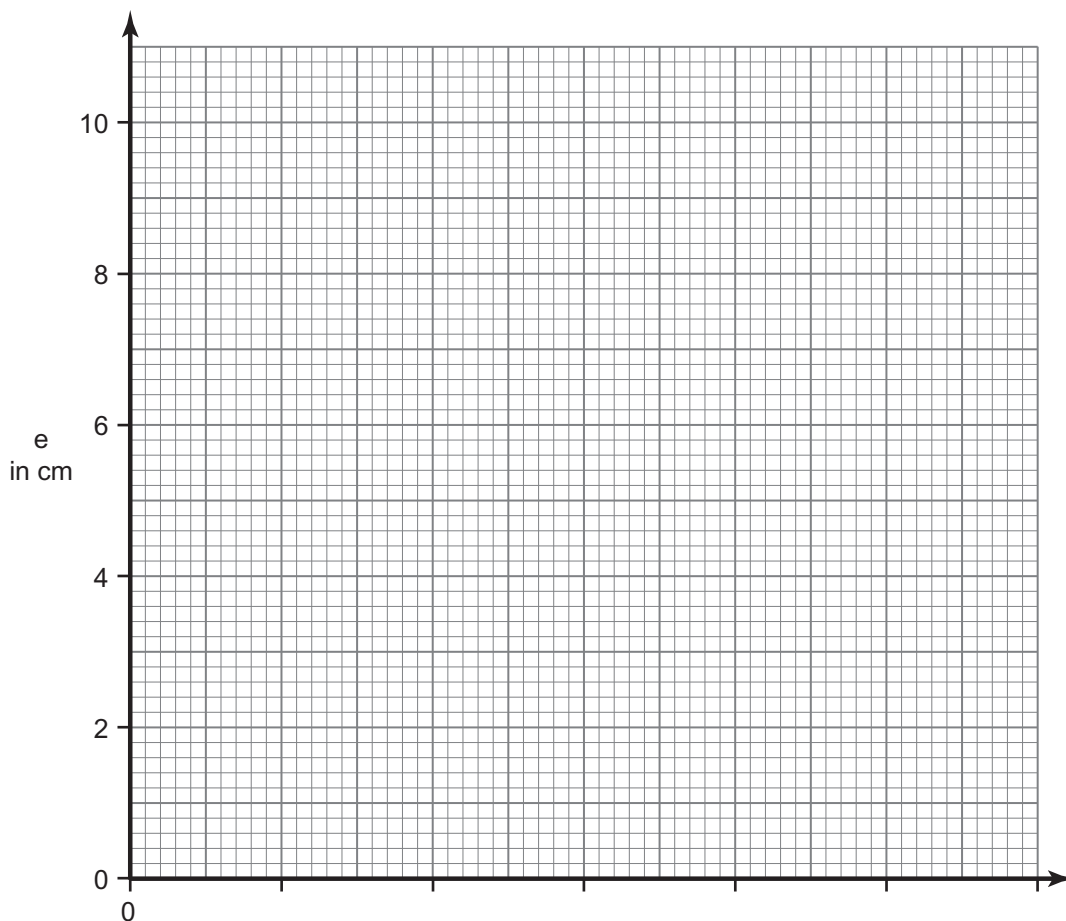

Examiner Only	
Marks	Remark
○	○

3 A steel ball was thrown downwards from a height above the surface of the Moon.

The graph shows part of the motion of the steel ball.

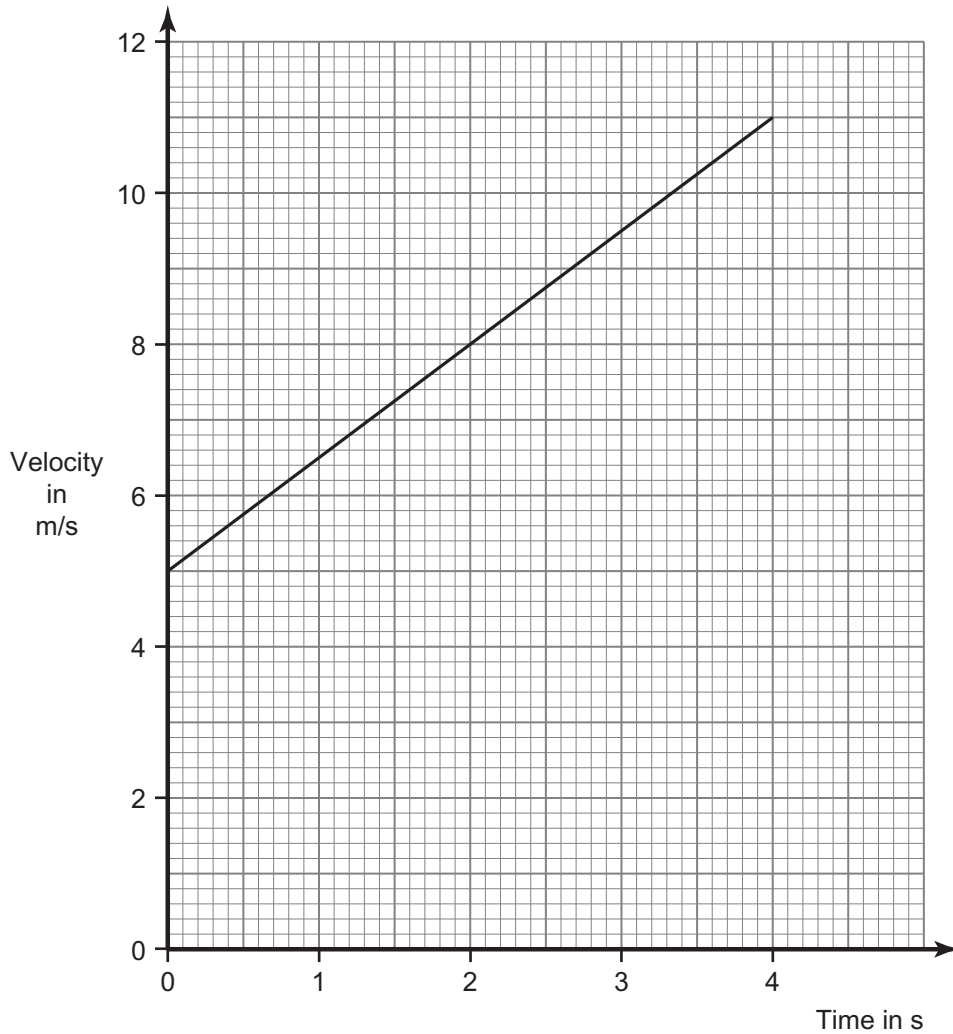

Use the graph to answer the following questions.

(a) (i) What is the initial velocity of the ball?

_____ m/s [1]

(ii) Describe the motion of the steel ball between times $t = 0$ s and $t = 4$ s.

_____ [1]

Examiner Only	
Marks	Remark
○	○

4 An isotope of iron has a half-life of 46 days.

(a) (i) Explain what is meant by a half-life of 46 days.

_____ [2]

A sample of this isotope has an activity of 512 disintegrations per second.

(ii) What length of time must pass before its activity falls to 32 disintegrations per second?

You are advised to show your working out.

Time = _____ days [3]

A source of radioactivity emits all three types of radiation: alpha, beta and gamma.

(b) (i) Which radiation(s) will pass through 3 cm of lead?

_____ [1]

(ii) Which radiation(s) will pass through a thick piece of cardboard?

_____ [1]

Examiner Only	
Marks	Remark
○	○

5 (a) Write, in words, the Principle of Moments.

[3]

John must find the weight of his suitcase before going on holiday.
He balanced a uniform plank of wood as shown in the diagram below.

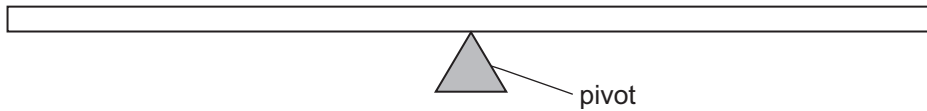

He then placed a weight of 300 N on the left hand side of the plank and his suitcase on the other side.

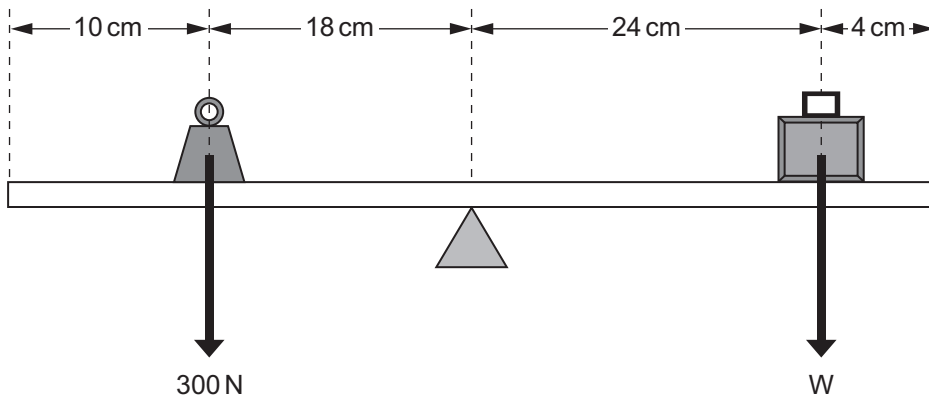

John adjusted the positions of the 300 N weight and the suitcase until the plank was in balance again.

(b) Calculate the weight of the suitcase.

You are advised to show your working out.

Weight = _____ N [4]

Examiner Only	
Marks	Remark
<input type="text"/>	<input type="text"/>

- 6 (a) Explain in terms of mass number and atomic number the meaning of the word isotope.

[2]

This part of the question is about a nuclear disintegration of an isotope of potassium by beta decay.

- (b) Potassium, K, undergoes beta decay to calcium, Ca.

Complete a balanced nuclear equation for this reaction.

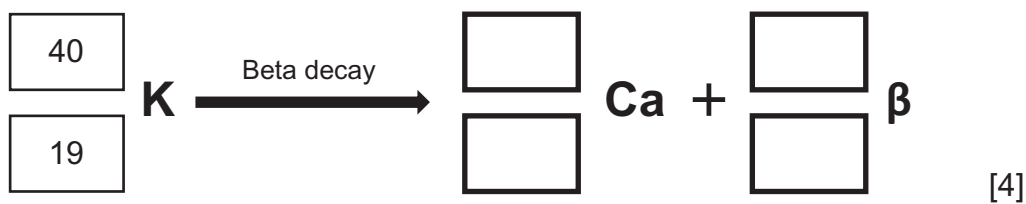

Examiner Only	
Marks	Remark
<input type="text"/>	<input type="text"/>

- 7 A toy car of mass 1.2 kg is released from rest at point A, before it loops the loop.

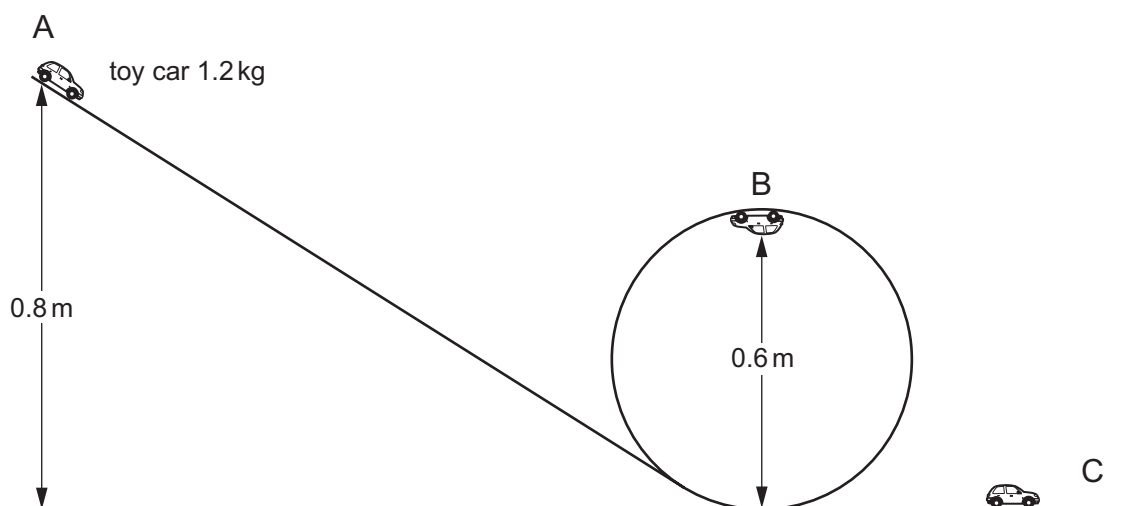

- (i) Calculate the **difference** in potential energy of the toy car at points A and B.

You are advised to show your working out.

Difference in potential energy = _____ J [4]

- (ii) Calculate the velocity of the toy car at point C, if its kinetic energy at C is 3.75 J.

You are advised to show your working out.

Velocity = _____ m/s [4]

Examiner Only	
Marks	Remark
<input type="text"/>	<input type="text"/>

- 8 A racing car, of mass 2500 kg, accelerates from rest on the starting grid. The engine exerts a force of 1.5×10^4 N.



© Gustoimages/Science Photo Library

- (a) Calculate the acceleration of the racing car.

You are advised to show your working out.

Acceleration = _____ m/s² [3]

- (b) The racing car accelerates for 10 s and covers a distance of 300 m.

Calculate the work done by the engine of the racing car.

Give your answer in megajoules.

You are advised to show your working out.

Work done = _____ MJ [4]

Examiner Only	
Marks	Remark
○	○

THIS IS THE END OF THE QUESTION PAPER

Permission to reproduce all copyright material has been applied for.
In some cases, efforts to contact copyright holders may have been unsuccessful and CCEA
will be happy to rectify any omissions of acknowledgement in future if notified.