



General Certificate of Secondary Education
2014

Double Award Science: Physics

Unit P2
Higher Tier
[GSD62]

ML

THURSDAY 12 JUNE 2014, MORNING

Centre Number

71	
----	--

Candidate Number

--

TIME

1 hour 15 minutes, plus your additional time allowance.

INSTRUCTIONS TO CANDIDATES

Write your Centre Number and Candidate Number in the spaces provided at the top of this page.
Write your answers in the spaces provided in this question paper.
Answer **all eight** questions.

INFORMATION FOR CANDIDATES

The total mark for this paper is 90.
Figures in brackets printed down the right-hand side of pages indicate the marks awarded to each question or part question.
Quality of written communication will be assessed in Question **7(c)(iii)**.

For Examiner's use only	
Question Number	Marks
1	
2	
3	
4	
5	
6	
7	
8	

Total Marks	
--------------------	--

1 Waves can be divided into two types.

(a) Name the two types of wave.

1. _____ 2. _____ [2]

(b) The graph of a water wave is illustrated below.

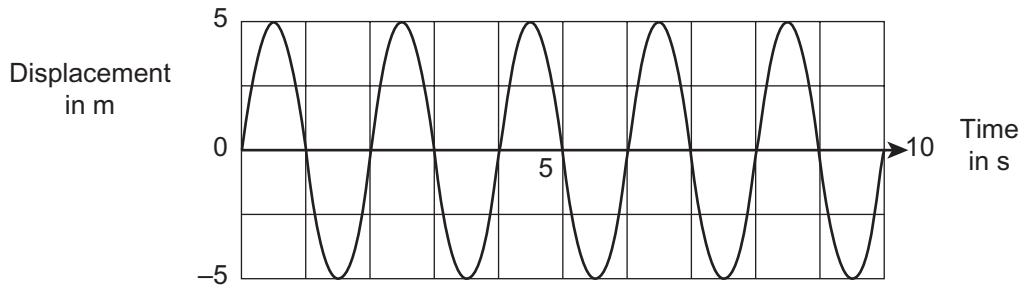

(i) What type of wave is the water wave?

_____ [1]

(ii) Describe the motion of the particles in the water wave.

_____ [2]

(iii) Use the graph to find the values of amplitude and frequency.

Amplitude = _____ m

Frequency = _____ Hz

[2]

Examiner Only	
Marks	Remark
○	○

- (c) A radio station broadcasts on 100 MHz. Calculate the wavelength if radio waves travel at 3.0×10^8 m/s.
Show your working out.

Wavelength = _____ m [4]

Examiner Only	
Marks	Remark

2 A letter L is put in front of a mirror as shown below.

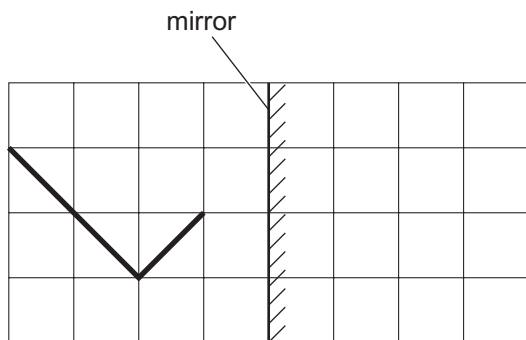

(a) Use the grid to draw the image of the letter L in the mirror. [2]

Two mirrors A and B are arranged at 120° as shown below. A ray of light is incident on mirror A.

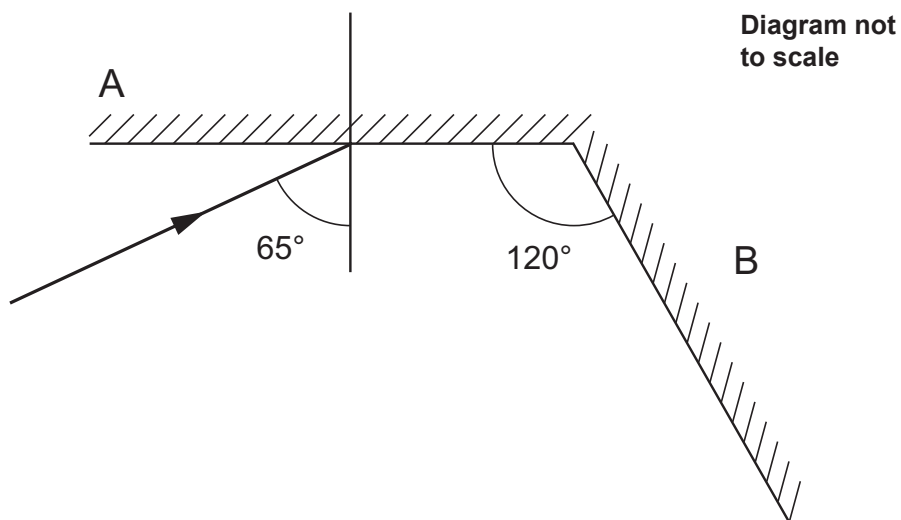

(b) (i) Continue the ray showing reflection in both mirrors. [2]

The angle of incidence of the above ray is 65° .

(ii) What is the angle of reflection of the ray reflected by mirror B?

Show your working out.

Angle of reflection = _____ [2]

Examiner Only	
Marks	Remark
○	○

- 3 The questions below are concerned with the structure of the Earth.
The diagram represents a cross section (not to scale) through the Earth.

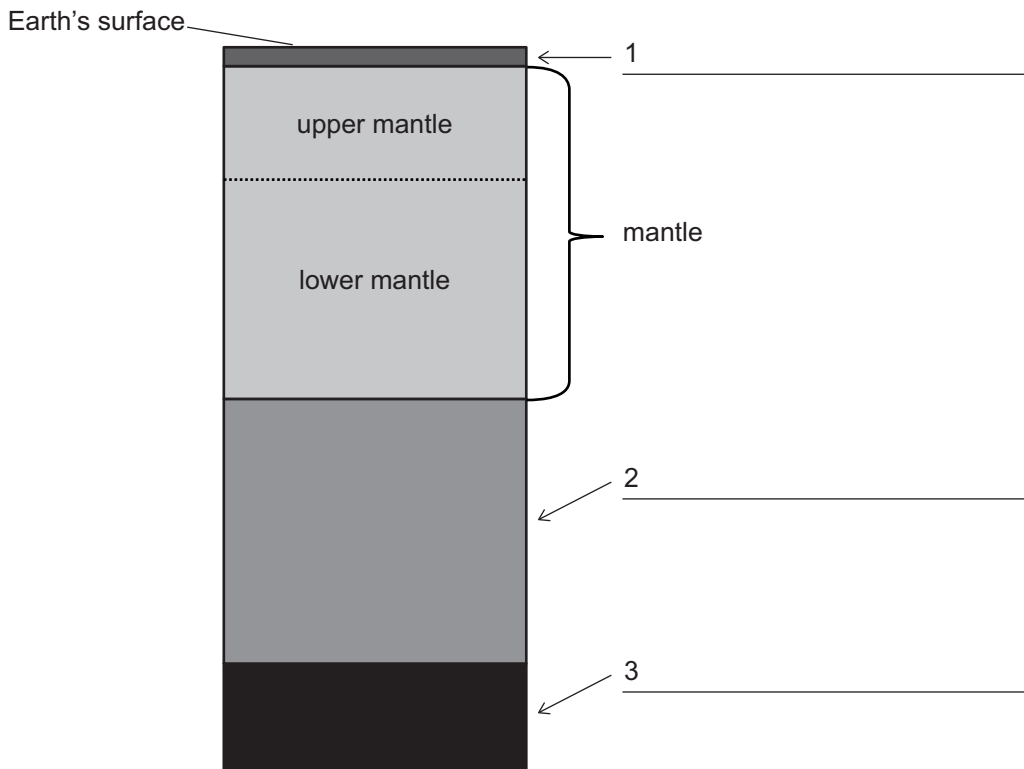

(a) The mantle has been labelled for you. Label the layers 1, 2 and 3. [3]

(b) Name two major elements found below the mantle.

1. _____

2. _____ [2]

Examiner Only	
Marks	Remark
<input type="text"/>	<input type="text"/>

The lithosphere is the layer of the Earth which is divided into plates, called tectonic plates.

(c) (i) What does “lithosphere” mean?

_____ [2]

(ii) What allows the tectonic plates to move?

_____ [1]

(iii) Name two large-scale processes which occur because of the movement of the plates that make up the lithosphere.

_____ and _____ [2]

Examiner Only	
Marks	Remark

- 4 A ball bearing is released at the surface of a liquid contained in a tall glass cylinder.

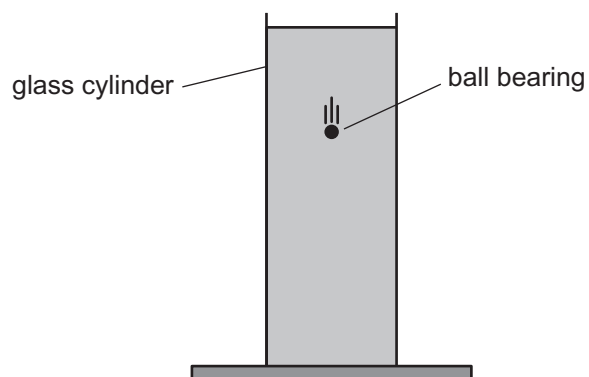

Its velocity is measured every second as it falls through the liquid and the results are recorded in the table.

Time in s	0	1	2	3	4	5	6	7
Velocity in cm/s	0	0.2	0.4	0.6	0.8	1.0	1.0	1.0

- (a) On the graph below choose and label a suitable scale on the vertical axis.

Plot points of velocity against time.

[4]

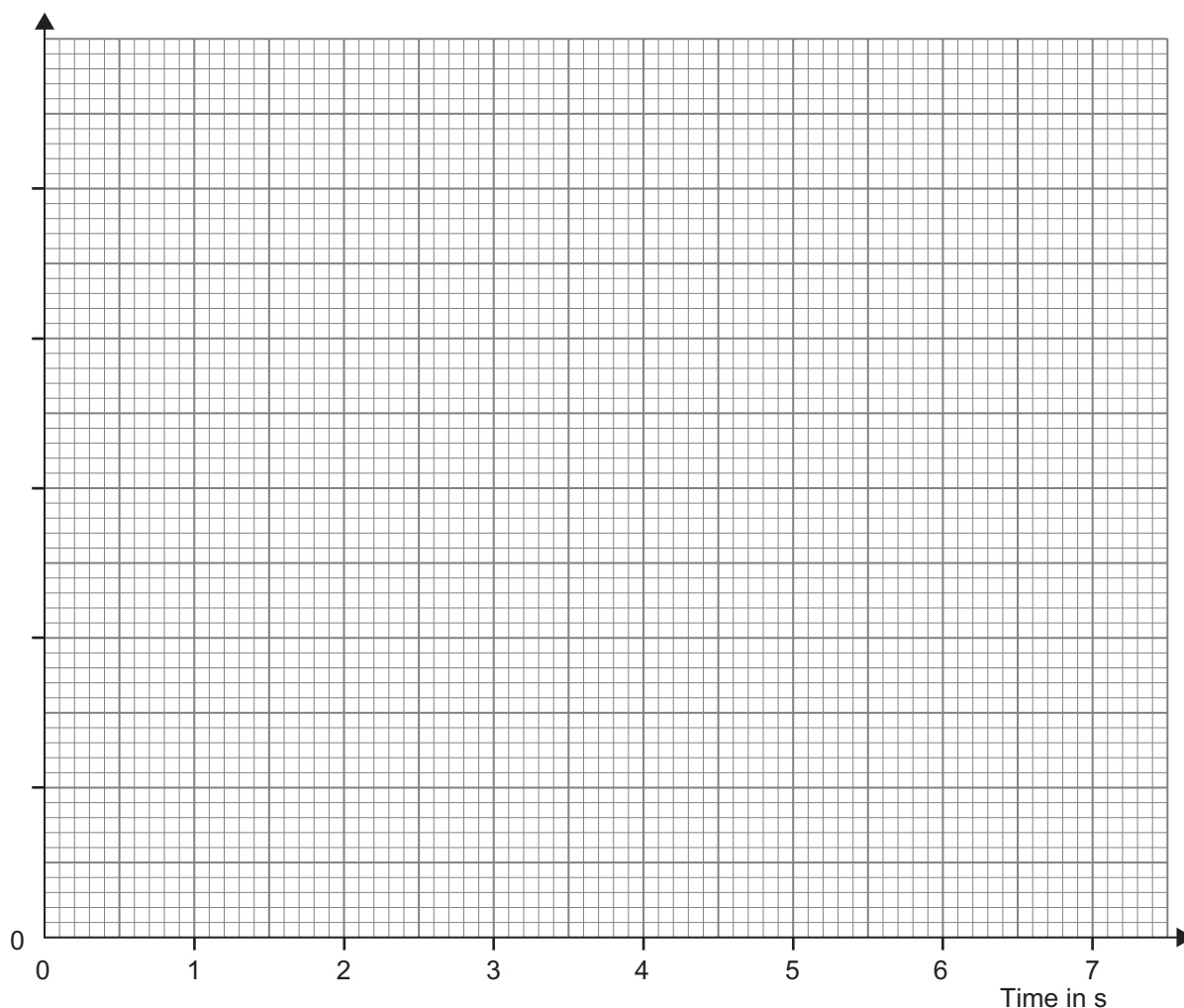

Examiner Only	
Marks	Remark
○	○

BLANK PAGE

(Questions continue overleaf)

6 Resistors are arranged in the following formation.

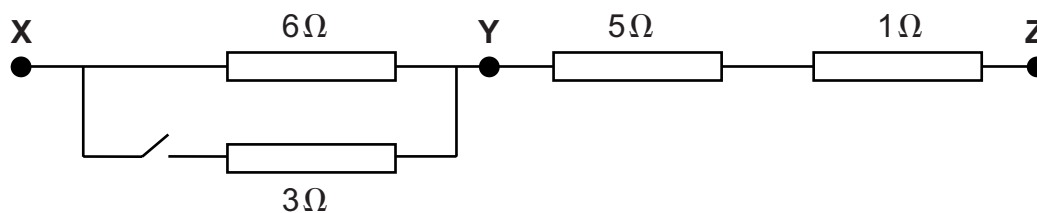

(a) (i) Calculate the resistance between points X and Y when the switch is closed.

Show your working out.

Resistance between X and Y = _____ Ω [3]

(ii) Complete the table to show the total resistance between the different switch settings.

Switch	Resistance between points in Ω	
Open	X and Z	
Closed	X and Z	

[2]

(b) When the switch is closed a current of 600 mA flows through the 1 Ω resistor. State the currents flowing through the other resistors.

Resistor	Current in mA
5 Ω	
6 Ω	
3 Ω	

[3]

Examiner Only	
Marks	Remark
○	○

- (c) (i) What is the voltage across an 8Ω resistor when a current of 600 mA is flowing through it?

Show your working out.

Voltage = _____ V [4]

- (ii) What is the power developed in the 8Ω resistor when 600 mA flows through it?
Remember to include the unit.

Show your working out.

Power = _____ [4]

Examiner Only	
Marks	Remark

- 7 A girl's hair is brushed with a plastic brush.
A few strands of hair are left sticking out.



© Andrew Lambert Photography / Science Photo Library

- (a) Explain fully why the strands of hair are sticking out.

[2]



- (b) A current of 0.2A flows through a resistor for 3 minutes. Calculate the charge which flows in this time interval.
Show your working out.

Charge = _____ C [4]

- (c) Amy is asked to find how the resistance of a metallic conductor depends on the area of cross section.

- (i) State two precautions she must take to make sure the experiment is a fair test.

[2]

Examiner Only	
Marks	Remark
	

(ii) Complete the circuit diagram to show how she would find the resistance of the metal wire.

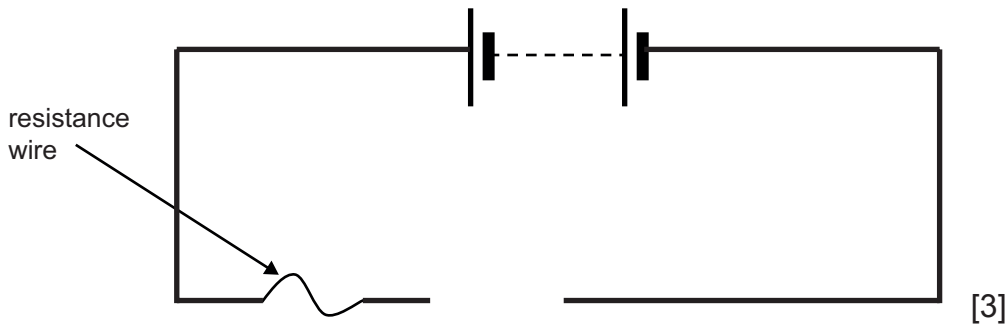

(iii) Describe the experiment Amy would carry out to investigate how the resistance of a wire would depend on its area of cross section. Your method should include:

- measurements to be taken,
- calculations to be made,
- the conclusion.

In this part of the question you will be assessed on your written communication skills, including the use of specialist scientific terms.

[6]

Examiner Only	
Marks	Remark

8 Luke holds a coil of wire between the poles of a large magnet.

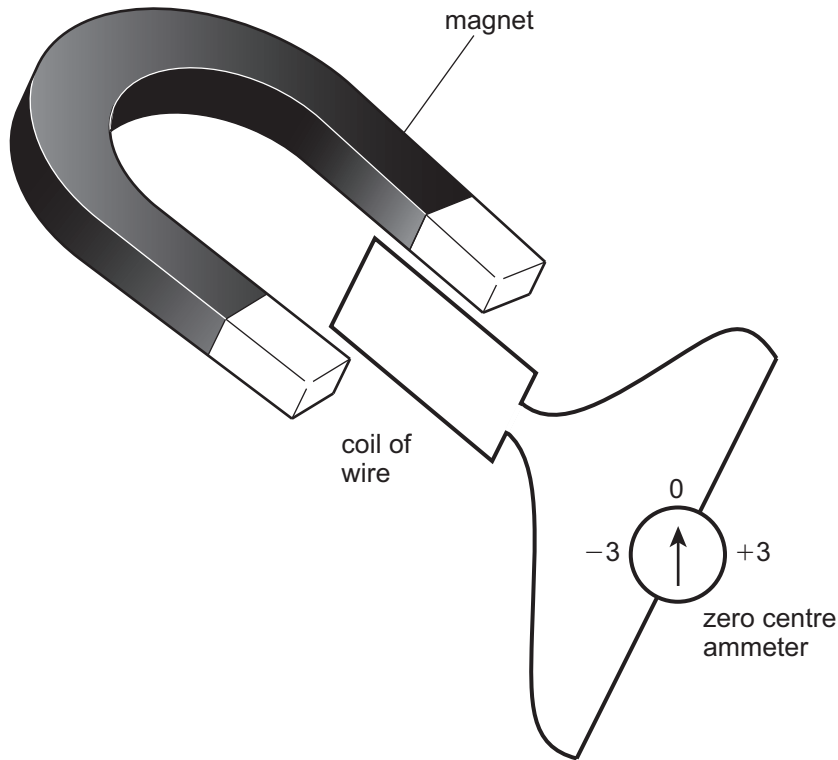

When Luke moves the coil into the gap between the poles of the magnet, the needle on the ammeter moves to -3 and returns to zero.

(a) (i) What happens when he removes the coil from the magnet?

[2]

Examiner Only	
Marks	Remark
0	0

- (ii) Draw a graph to show the output you would expect to obtain from an a.c. generator.

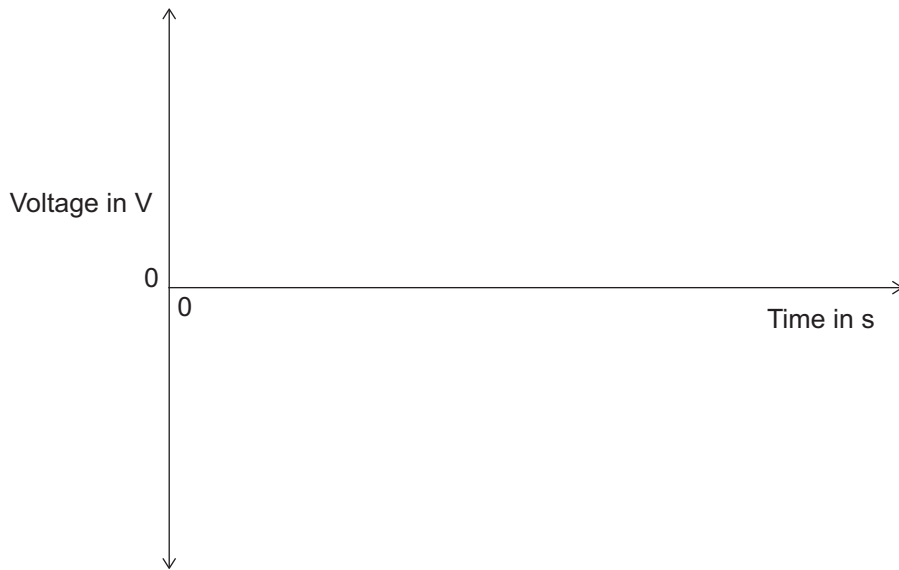

[2]

- (b) A transformer for an electric shaver reduces the mains voltage of 240V to 12V.

- (i) What is the turns ratio?

$$\frac{\text{Turns on secondary coil}}{\text{Turns on primary coil}} = \quad [1]$$

- (ii) If there are 600 turns on the secondary coil, how many are there on the primary coil?

Show your working out.

Number of turns = _____ [2]

Examiner Only	
Marks	Remark

(c) The following diagram shows the National Grid transmission system.

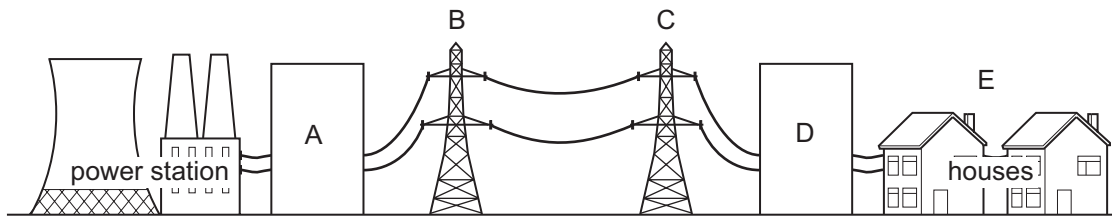

(i) Between which two points (A to E) is the energy loss greatest in the transmission system?

_____ [1]

(ii) Explain fully how this energy loss is reduced, using a transformer.

_____ [2]

THIS IS THE END OF THE QUESTION PAPER

Examiner Only	
Marks	Remark
<input type="text"/>	<input type="text"/>

Permission to reproduce all copyright material has been applied for.
In some cases, efforts to contact copyright holders may have been unsuccessful and CCEA
will be happy to rectify any omissions of acknowledgement in future if notified.