



Centre Number

71	
----	--

Candidate Number

--

General Certificate of Secondary Education  
2013–2014

---

## Double Award Science: Physics

Unit P1

Higher Tier

[GSD32]

MV18

MONDAY 19 MAY 2014, AFTERNOON

---

### TIME

1 hour, plus your additional time allowance.

### INSTRUCTIONS TO CANDIDATES

Write your Centre Number and Candidate Number in the spaces provided at the top of this page.

Write your answers in the spaces provided in this question paper.

Answer **all nine** questions.

### INFORMATION FOR CANDIDATES

The total mark for this paper is 70.

Figures in brackets printed at the end of each question indicate the marks awarded to each question or part question.

Quality of written communication will be assessed in Questions **2(a)** and **5**.

---

- 1 According to theory, the range  $R$  of a cannonball depends on the horizontal velocity  $v$  when fired from the top of a cliff.

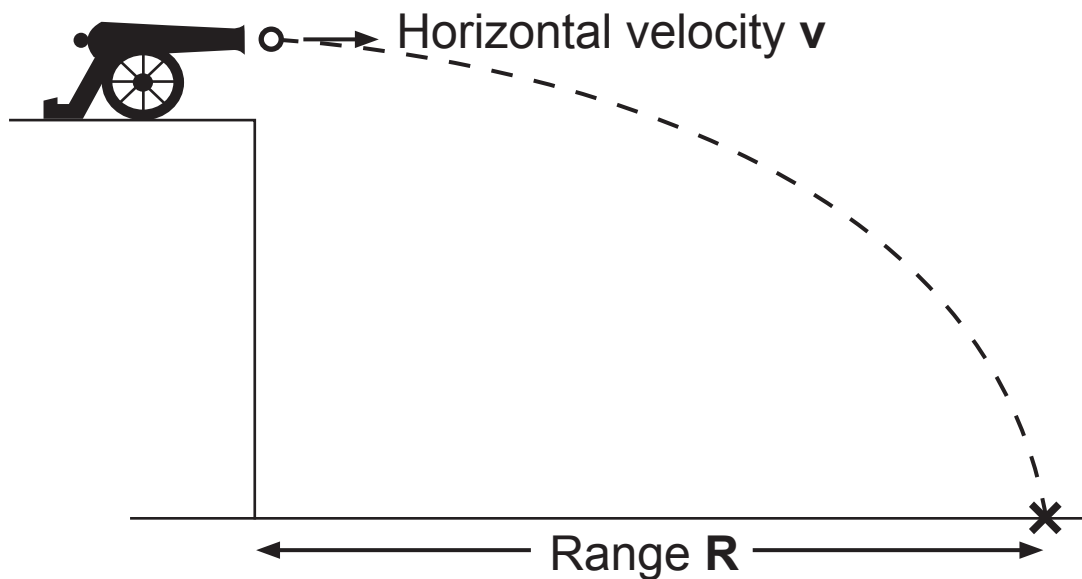

A series of readings is shown in the table.

$v/$ $m/s$	0	5	10	15	20
$R/m$	0	30	60	90	120

- (a) (i) Label and choose a suitable scale for the vertical axis. [2 marks]
- (ii) Plot the points on the grid and draw the straight line of best fit. [3 marks]

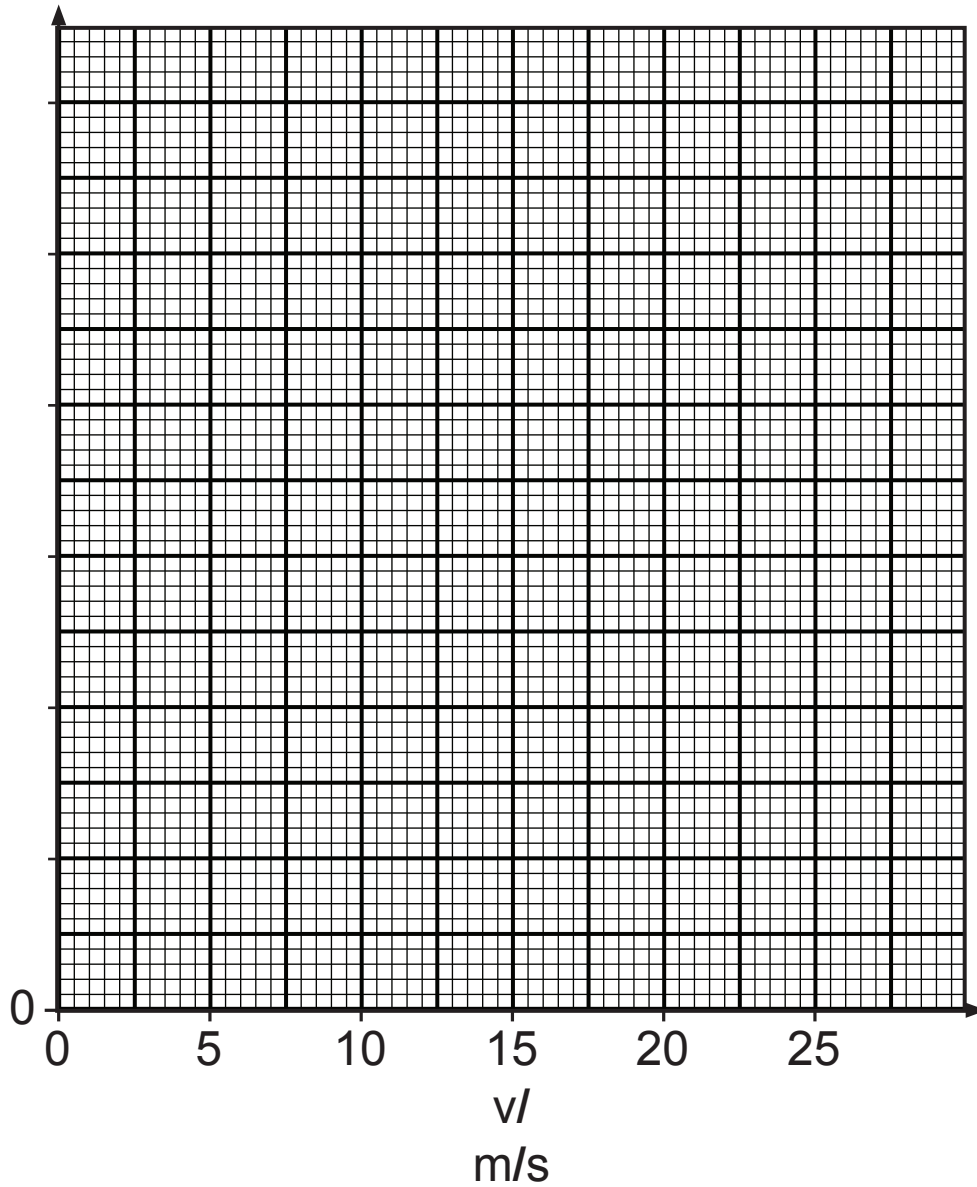

(b) Find the gradient of the graph. [4 marks]  
 Remember to include the unit for the gradient.  
**You are advised to show your working out.**

Gradient = \_\_\_\_\_

Unit = \_\_\_\_\_

(c) Use the graph to find the range, **R**, of the cannonball when its horizontal velocity is 12 m/s. [1 mark]

Range = \_\_\_\_\_ m

**BLANK PAGE**

**(Questions continue overleaf)**

**2 (a) Describe the process of nuclear fusion. [6 marks]**

Your description should include:

- the particles involved
- what happens when nuclear fusion takes place
- where nuclear fusion occurs naturally

**In this question you will be assessed on your written communication skills including the use of specialist scientific terms.**

---

---

---

---

---

---

---

---

---

---

---

---

---

(b) A great deal of money is being invested on research into nuclear **fusion**.

(i) Suggest a reason why. [1 mark]

---

(ii) Give two practical difficulties which must be overcome before fusion reactors become viable. [2 marks]

1. \_\_\_\_\_

2. \_\_\_\_\_

- 3 An electric motor lifts a block of stone, of weight 150 N, through a vertical distance of 840 cm.

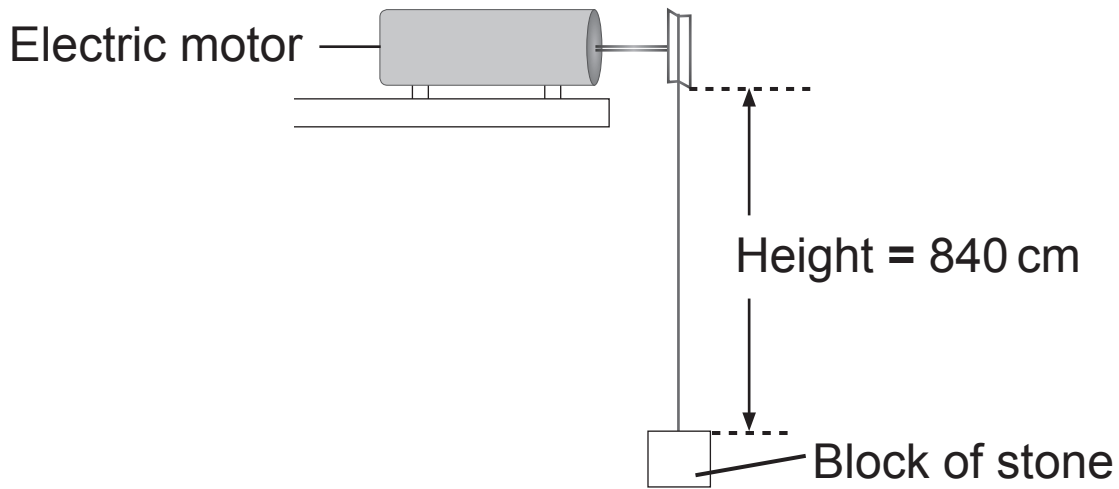

- (i) Calculate the work done. [4 marks]

**You are advised to show your working out.**

Work done = \_\_\_\_\_ J

- (ii) Into what energy form has this work been changed?  
[1 mark]

Work has become \_\_\_\_\_



**(iii)** If the motor uses 2100 J of electrical energy, calculate the efficiency of the motor. [3 marks]

**You are advised to show your working out.**

Efficiency = \_\_\_\_\_

4 An aluminium block has the dimensions shown.

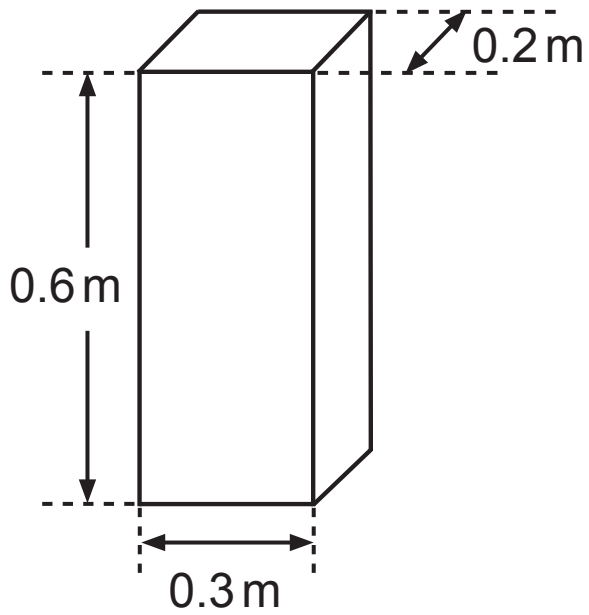

Diagram not  
drawn to scale

(i) Find the volume of the aluminium block, in  $\text{m}^3$ . [2 marks]

**You are advised to show your working out.**

Volume = \_\_\_\_\_  $\text{m}^3$

The density of aluminium is  $2700 \text{ kg/m}^3$ .

(ii) Calculate the mass of the block. [3 marks]

**You are advised to show your working out.**

Mass = \_\_\_\_\_ kg

**BLANK PAGE**

**5** Describe an experiment you would carry out in the laboratory to test how the acceleration of an object depends on the accelerating force. You should include the following:  
[6 marks]

- the readings you take,
- how the readings are used to get a relationship,
- the outcome of your experiment.

**In this question you will be assessed on your written communication skills including the use of specialist scientific terms.**

---

---

---

---

---

---

---

---

---

---

---

---

---

---

---

---

---

---

---

---

---

---

---

---

- 6 A skydiver jumps from an aircraft and for a time falls through the air without his parachute open. After a time he opens his parachute.

The diagram shows the velocity–time graph of his fall.

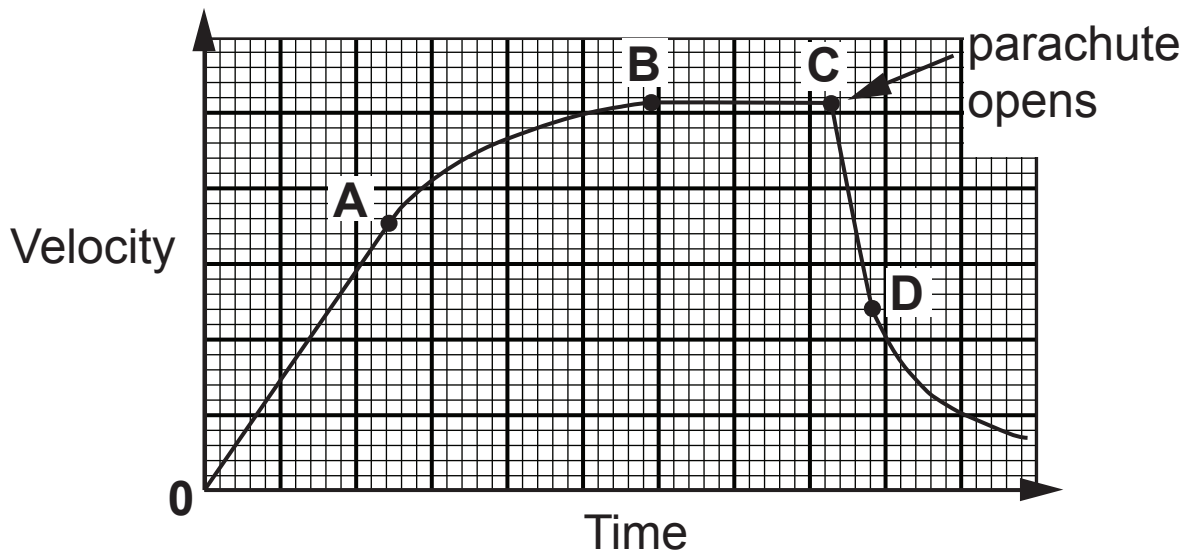

Use the letters on the graph to answer the following questions.

- (a) (i) During what time interval is he falling at constant velocity? [1 mark]

From \_\_\_\_\_ to \_\_\_\_\_

- (ii) During what time interval are the forces acting on the skydiver balanced? [1 mark]

From \_\_\_\_\_ to \_\_\_\_\_

- (iii) During what time interval is the force acting upward on the skydiver greater than the weight of the skydiver? [1 mark]

From \_\_\_\_\_ to \_\_\_\_\_

(iv) Give the name of the upward force in part (iii).  
[1 mark]

---

A velocity–time graph for a different skydiver is shown below from the instant that the parachute opens.

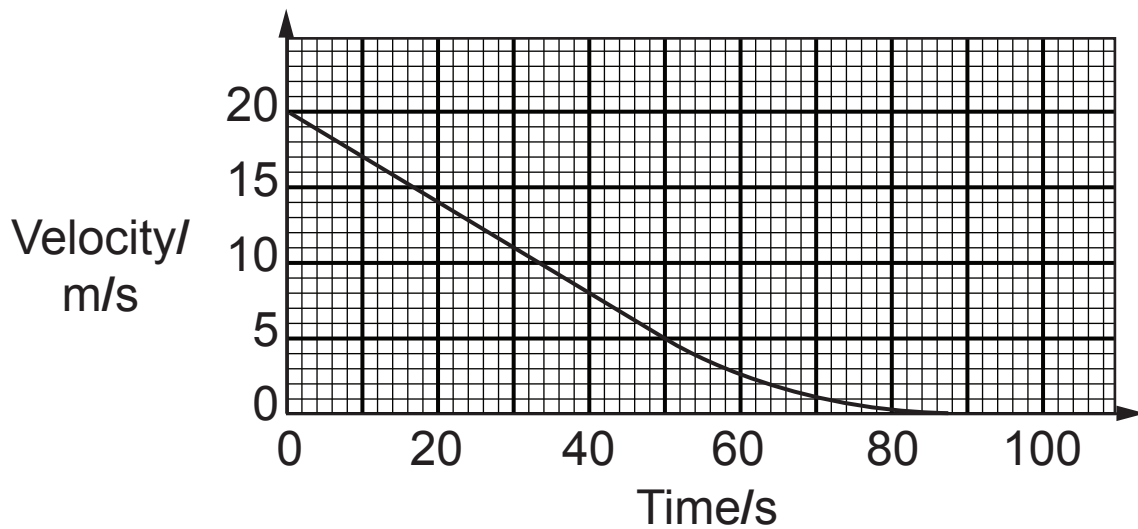

(b) Calculate how far the skydiver falls in the first 50 seconds. [4 marks]

You are advised to show your working out.

Height = \_\_\_\_\_ m

**BLANK PAGE**



7 A radioactive nucleus of uranium decays by emitting a beta particle.

(a) Complete the equation below by writing the correct numbers in the boxes. [4 marks]

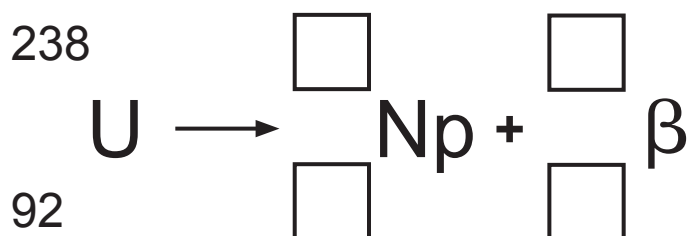

(b) (i) Neptunium (Np) has a half-life of 46 days.

Explain fully what is meant by the term 'half-life'.  
[2 marks]

---

---

---

(ii) Starting with 50.00 grams of neptunium, calculate how long it takes for 43.75 grams of it to decay.  
[4 marks]

**You are advised to show your working out.**

Time = \_\_\_\_\_ days

8 (a) State the Principle of Moments. [2 marks]

---

---

---

(b) (i) A non-uniform plank of wood of length 80 cm is balanced on a pivot as shown.

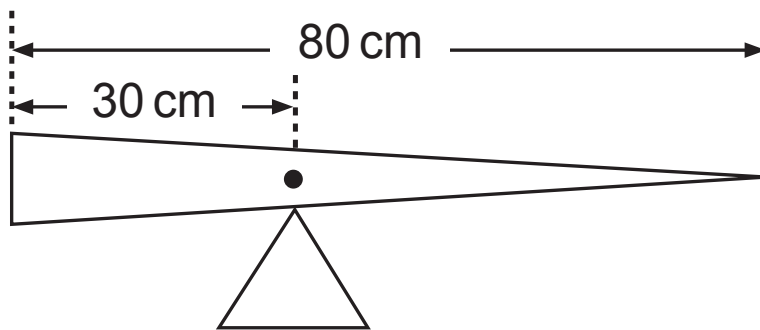

We now know that the position of the centre of gravity of the plank is 30 cm from the left-hand end and this is indicated by a dot as shown.

The plank is now moved and **rebalanced at its mid-point** using a 5 N weight placed 8 cm from the right-hand end.

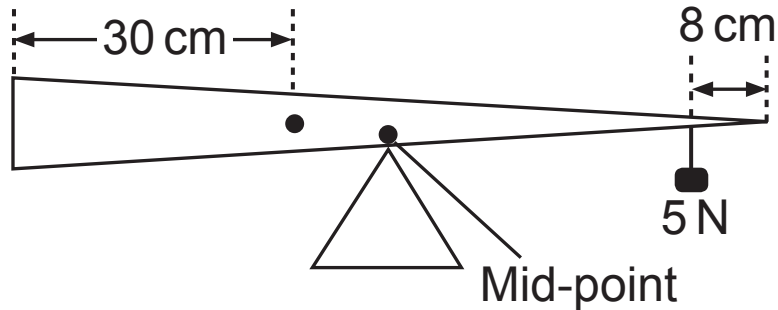

Calculate the weight of the plank. [3 marks]

**You are advised to show your working out.**

Weight of plank = \_\_\_\_\_ N

(ii) Calculate the upward force which is now exerted by the triangular support. [1 mark]

Upward force = \_\_\_\_\_ N

- 9 A boulder, of mass 440 kg, rolls down a slope and into the sea.

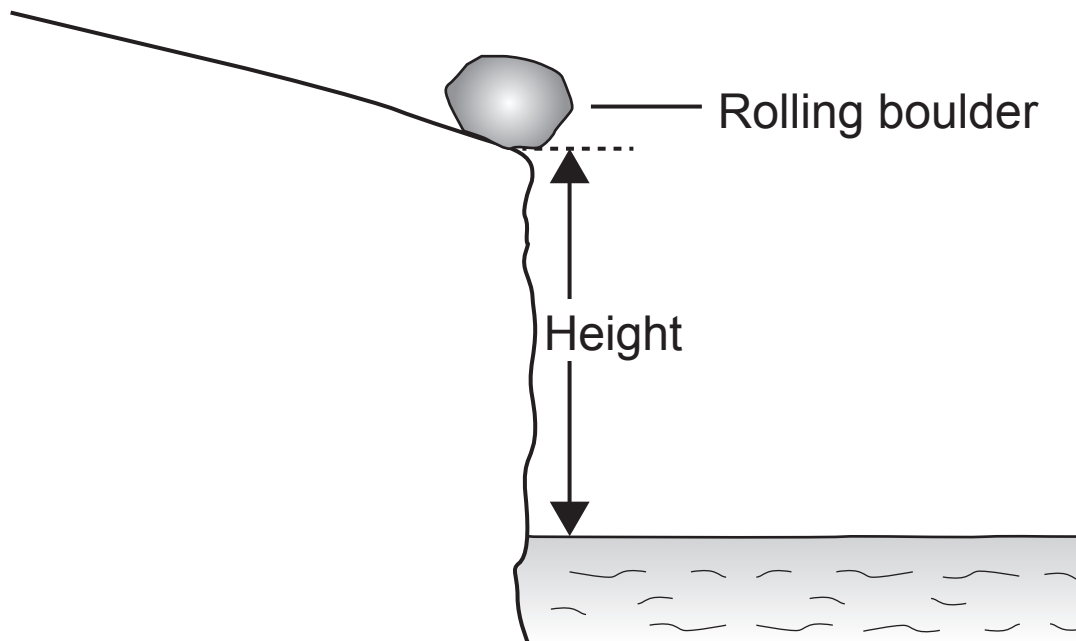

In the position shown at the edge of the cliff the boulder has a kinetic energy of 3520 J and a potential energy of 52 800 J.

- (a) Calculate the height of the cliff. [3 marks]

**You are advised to show your working out.**

Height of cliff = \_\_\_\_\_ m

- (b) (i)** Calculate the kinetic energy of the boulder as it strikes the water. [1 mark]  
Assume no energy losses.

Kinetic energy = \_\_\_\_\_ J

- (ii)** Calculate the velocity of the boulder when it hits the water. [4 marks]

**You are advised to show your working out.**

Velocity = \_\_\_\_\_ m/s

---

**THIS IS THE END OF THE QUESTION PAPER**

---





<b>For Examiner's use only</b>	
<b>Question Number</b>	<b>Marks</b>
1	
2	
3	
4	
5	
6	
7	
8	
9	
<b>Total Marks</b>	

Permission to reproduce all copyright material has been applied for.  
In some cases, efforts to contact copyright holders may have been unsuccessful and CCEA will be happy to rectify any omissions of acknowledgement in future if notified.