



Rewarding Learning

General Certificate of Secondary Education
2013–2014

Double Award Science: Physics

Unit P1

Higher Tier

[GSD32]

ML

FRIDAY 15 NOVEMBER 2013, AFTERNOON

Centre Number

71

Candidate Number

TIME

1 hour, plus your additional time allowance.

INSTRUCTIONS TO CANDIDATES

Write your Centre Number and Candidate Number in the spaces provided at the top of this page.

Write your answers in the spaces provided in this question paper.
Answer **all nine** questions.

INFORMATION FOR CANDIDATES

The total mark for this paper is 70.

Figures in brackets printed down the right-hand side of pages indicate the marks awarded to each question or part question.

Quality of written communication will be assessed in questions **2** and **7**.

For Examiner's use only

Question Number	Marks
1	
2	
3	
4	
5	
6	
7	
8	
9	

Total Marks

1 (a) The symbol for Uranium-235 is

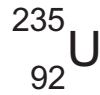

- (i) How many protons does a nucleus of Uranium-235 contain?
_____ [1]
- (ii) What name is given to this number of protons?
_____ [1]
- (iii) How many neutrons does a nucleus of Uranium-235 contain?
_____ [1]
- (iv) What name is given to the total number of protons and neutrons in the nucleus of Uranium-235?
_____ [1]

(b) Radioactive materials emit radiations that have particular natures and properties.

Complete the table below, linking the radiations to their natures and properties. One arrow has been done for you.

Use only **five** straight arrows.

Nature of radiation	Name of radiation	Property of radiation
Helium nuclei	• alpha •	Is absorbed by a few cm of air
High frequency electromagnetic radiation	• beta •	Can penetrate 3 cm of lead
High speed electrons	• gamma •	Can penetrate a thick piece of card, but not 3 cm of lead

[5]

Examiner Only	
Marks	Remark
○	○

2 The modern theory for the structure of the atom is quite different from the earlier theory that it replaced.



Write a brief account of both theories.

Your discussion should include:

- the name of each theory; and
- a description of how the particles are arranged in each theory.

In this question you will be assessed on your written communication skills including the use of specialist scientific terms.

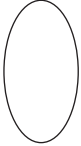
[6]

Examiner Only	
Marks	Remark
	

BLANK PAGE
(Questions continue overleaf)

- 3 A pupil is investigating “bending beams”. The pupil uses the apparatus shown below.

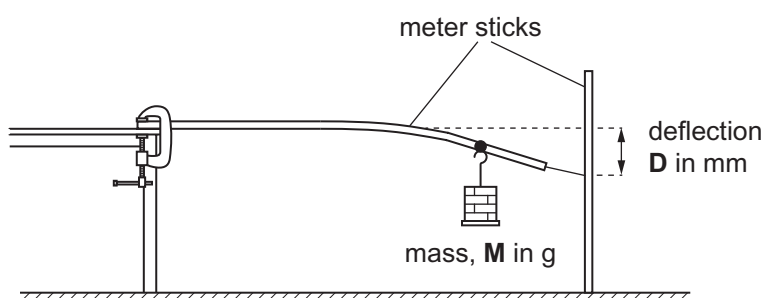

According to theory, the mathematical relationship between the deflection (**D**) of the beam and the mass (**M**) hung from the beam is given by

$$D = k M \quad \text{Equation 3.1}$$

The results the pupil collected are as follows.

Mass M in g	Deflection D in mm
50	1.5
100	3.0
150	4.5
200	6.0
250	7.5

Examiner Only

Marks Remark

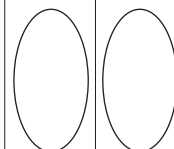

- (a) Choose a suitable horizontal scale and label the horizontal axis. Plot a graph of **D** on the vertical axis versus **M** on the horizontal axis on the grid below.

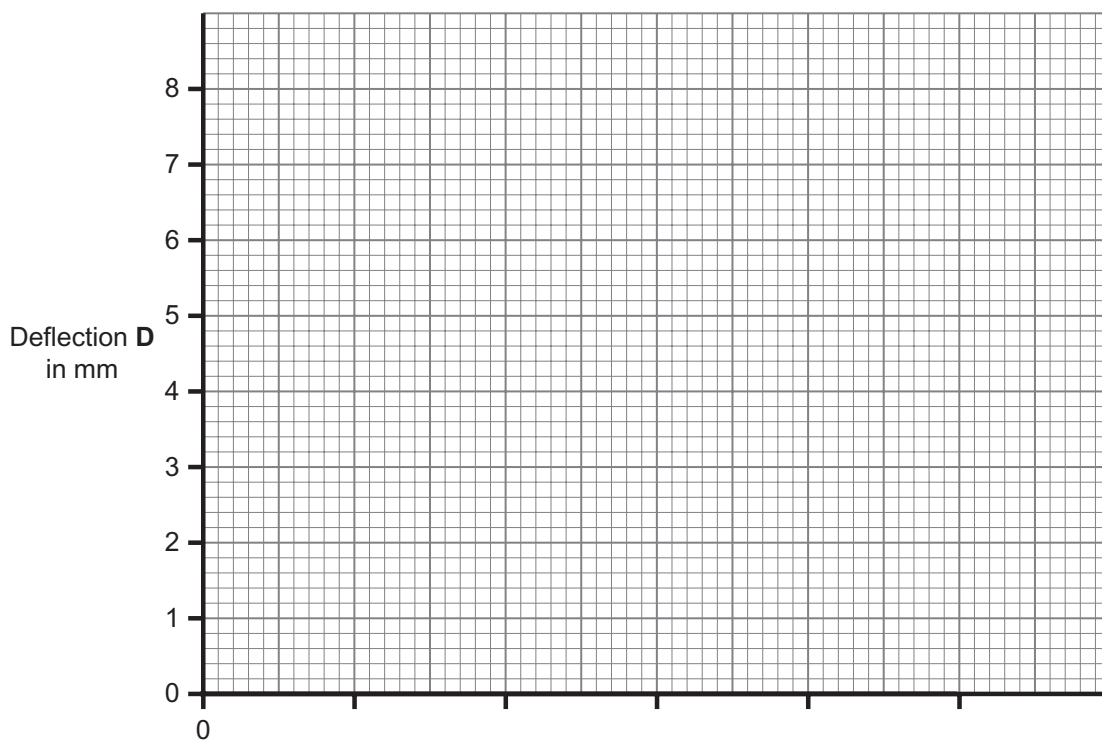

[4]

- (b) Draw a line of best fit.

[1]

- (c) (i) Use your graph to determine the constant k , in **Equation 3.1**.

Remember to include the unit for k .

$$k = \text{_____} : \text{Unit} = \text{_____} \quad [4]$$

- (ii) Use your graph to find the deflection for a mass of 125 g.

$$\text{Deflection} = \text{_____} \text{ mm} \quad [1]$$

Examiner Only	
Marks	Remark

4 Look at the diagram below. It shows a playground roundabout.

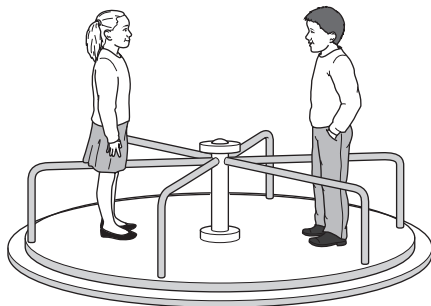

Holly and Brian stand the same distance from the centre of a revolving roundabout.

Brian has a mass of 35 kg and Holly a mass of 20 kg.

(a) (i) How does the centripetal force acting on Brian compare with the centripetal force acting on Holly?

Place a tick (✓) in the correct box.

The centripetal force acting on Brian is:

greater than that acting on Holly.

equal to that acting on Holly.

less than that acting on Holly.

[1]

Examiner Only	
Marks	Remark
○	○

Brian now stands at the outer edge of the roundabout where his radius is larger. However, his speed is the same as it was in part (i).

(ii) How does the centripetal force acting on Brian now compare with that in part (i)?

Place a tick (✓) in the correct box.

The centripetal force acting on Brian is:

greater than in part (i).

equal to that in part (i).

less than that in part (i).

[1]

(b) At a given instant Holly is travelling with a velocity of 0.75 m/s. Calculate her momentum in kg m/s. Remember Holly's mass is 20 kg.

You should show your working out.

Momentum = _____ kg m/s [3]

Examiner Only	
Marks	Remark

- 5 Mary and Neil run towards each other. Mary runs with a constant speed of 3 m/s and Neil with a constant speed of 2 m/s.

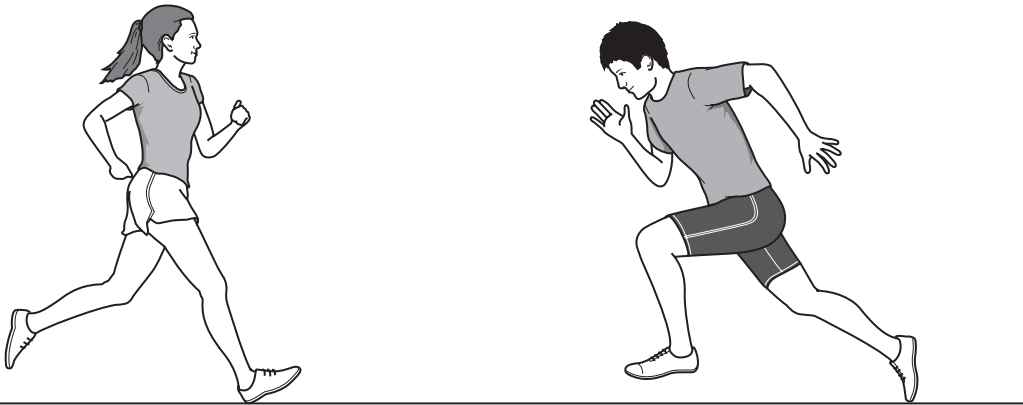

Mary's velocity–time graph is shown below.

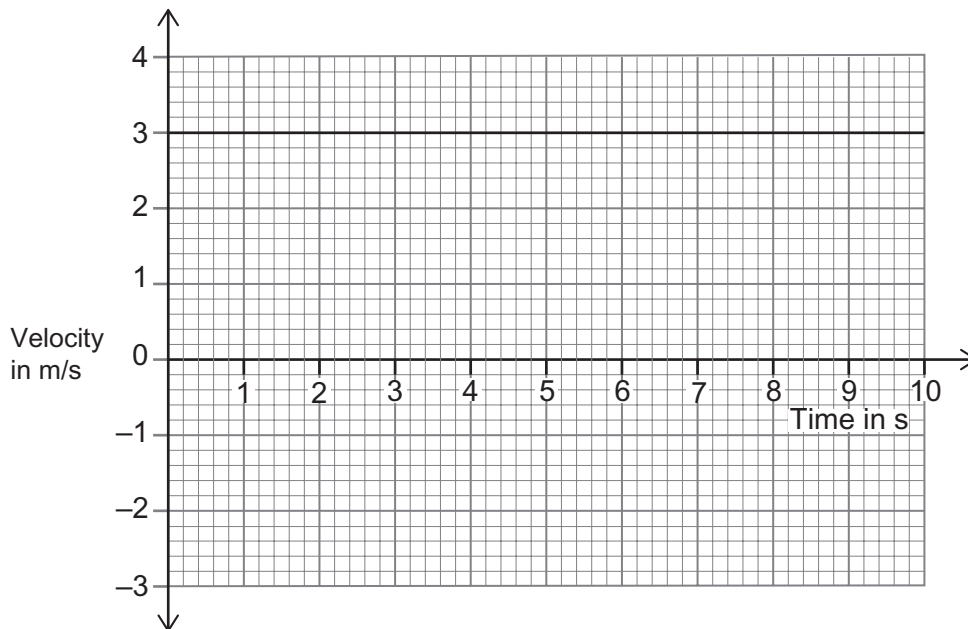

- (a) (i) Draw Neil's velocity–time graph on the axes above. [2]

The runners pass each other when Mary has run a distance of 21 m.

- (ii) At what time do they pass?

You should show your working out.

Time = _____ s [3]

Examiner Only	
Marks	Remark
○	○

On another occasion Mary's velocity–time graph is as shown below.

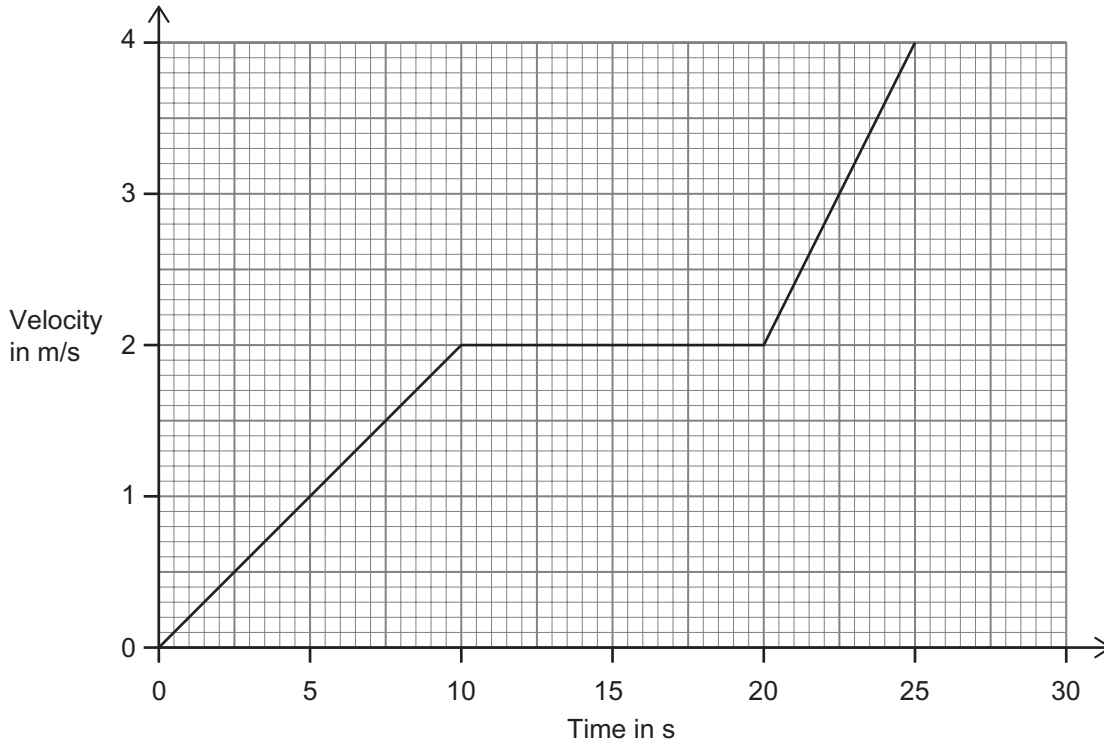

(b) Use the graph to find Mary's **maximum** acceleration.

You should show your working out.

Maximum acceleration = _____ m/s² [4]

Examiner Only	
Marks	Remark

6 Nuclear fusion is an energy source.

(a) Where, in our solar system, does fusion occur naturally?

_____ [1]

This part of the question is about a nuclear disintegration involving alpha decay.

(b) Uranium undergoes alpha (α) decay to Thorium.

Complete a balanced nuclear equation for this reaction.

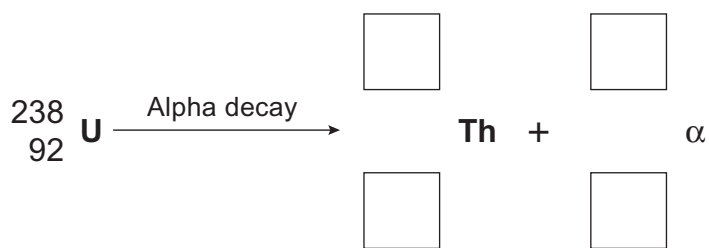

[4]

Examiner Only	
Marks	Remark
○	○

8 (i) State the Principle of Moments.

[2]

Donal places a uniform piece of wood of mass 120 g on a table and keeps it from falling off the table by pressing down as shown.

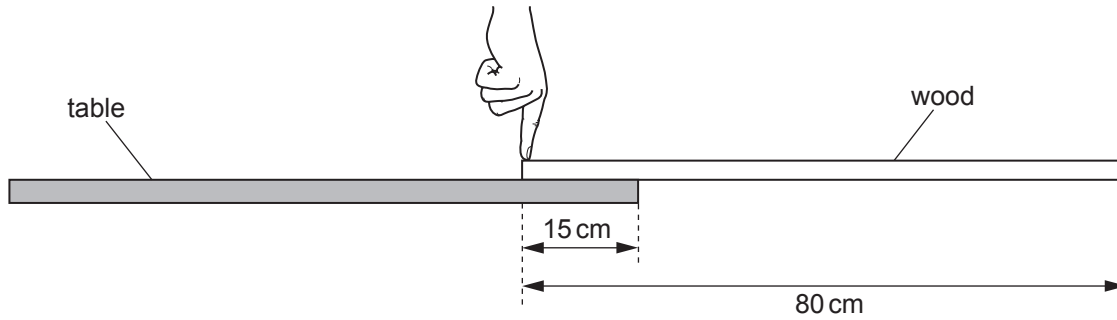

(ii) Draw an arrow, acting from the correct point, to show the direction of the weight of the piece of wood. Label this arrow with the weight of the wood, in N. [2]

(iii) Calculate the moment of the weight of the wood, in Ncm, about the right edge of the table.

You should show your working out.

Moment = _____ Ncm [3]

(iv) Calculate the downward force Donal exerts.

You should show your working out.

Force = _____ N [2]

Examiner Only	
Marks	Remark

9 A bullet is fired into a piece of wood in a forensic testing laboratory.

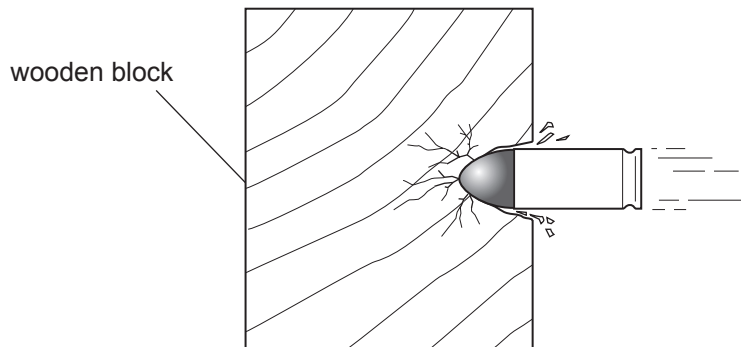

The average resistive force acting on the bullet as it becomes embedded in the wood is 1960 N. The bullet stops a distance of 15.0 cm into the wood.

(i) Show that the work done in stopping the bullet is 294 J.

You should show your working out.

[2]

(ii) The bullet has a mass of 0.03 kg. Calculate the entry velocity of the bullet. Ignore energy losses.

You should show your working out.

Velocity = _____ m/s [4]

THIS IS THE END OF THE QUESTION PAPER

Examiner Only	
Marks	Remark
<input type="text"/>	<input type="text"/>

Permission to reproduce all copyright material has been applied for.
In some cases, efforts to contact copyright holders may have been unsuccessful and CCEA
will be happy to rectify any omissions of acknowledgement in future if notified.