



Centre Number

71	
----	--

Candidate Number

--

General Certificate of Secondary Education
2013–2014

Double Award Science: Physics

Unit P1

Higher Tier

[GSD32]

MV18

FRIDAY 15 NOVEMBER 2013, AFTERNOON

TIME

1 hour, plus your additional time allowance.

INSTRUCTIONS TO CANDIDATES

Write your Centre Number and Candidate Number in the spaces provided at the top of this page.

Write your answers in the spaces provided in this question paper.

Answer **all nine** questions.

INFORMATION FOR CANDIDATES

The total mark for this paper is 70.

Figures in brackets printed at the end of each question indicate the marks awarded to each question or part question.

Quality of written communication will be assessed in questions **2** and **7**.

1 (a) The symbol for Uranium-235 is ${}^{235}_{92}\text{U}$

(i) How many protons does a nucleus of Uranium-235 contain? [1]

(ii) What name is given to this number of protons? [1]

(iii) How many neutrons does a nucleus of Uranium-235 contain? [1]

(iv) What name is given to the total number of protons and neutrons in the nucleus of Uranium-235? [1]

(b) Radioactive materials emit radiations which have particular natures and properties.

Complete the table below, linking the radiations to their natures and properties. One arrow has been inserted for you.

Use only **five** straight arrows. [5]

Nature of radiation	Name of radiation	Property of radiation
Helium nuclei	• alpha •	Is absorbed by a few cm of air
High frequency electromagnetic radiation	• beta •	Can penetrate 3cm of lead
High speed electrons	• gamma •	Can penetrate a thick piece of card, but not 3cm of lead

(c) Nuclear reactors rely on the fission of Uranium-235.

(i) What is the first stage of the nuclear fission process?
[2]

(ii) What happens during the nuclear fission process?
[2]

(iii) What is the name of the particle which sustains the chain reaction? [1]

- 2 The modern theory for the structure of the atom is quite different from the earlier theory which it replaced.

Write a brief account of both theories. [6]

Your discussion should include:

- the name of each theory; and
- a description of how the particles are arranged in each theory.

In this question you will be assessed on your written communication skills including the use of specialist scientific terms.

- 3 Gillian is investigating “bending beams”. She uses the apparatus shown below.

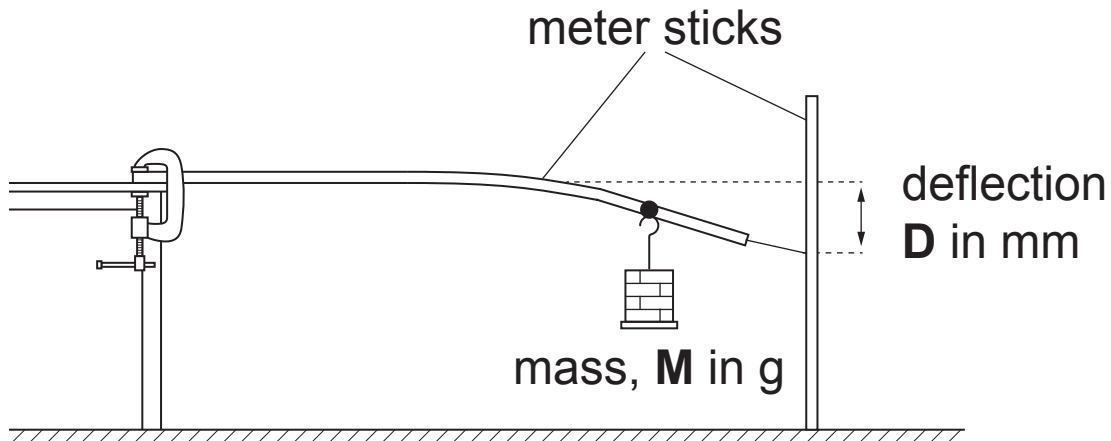

According to theory, the mathematical relationship between the deflection (**D**) of the beam and the mass (**M**) hung from the beam is given by

$$\mathbf{D = k M} \qquad \mathbf{Equation 3.1}$$

The results Gillian collected are found in the table overleaf.

Mass M in g	Deflection D in mm
50	1.5
100	3.0
150	4.5
200	6.0
250	7.5

- (a) Choose a suitable horizontal scale and label the horizontal axis. Plot a graph of D on the vertical axis versus M on the horizontal axis on the grid below. [4]

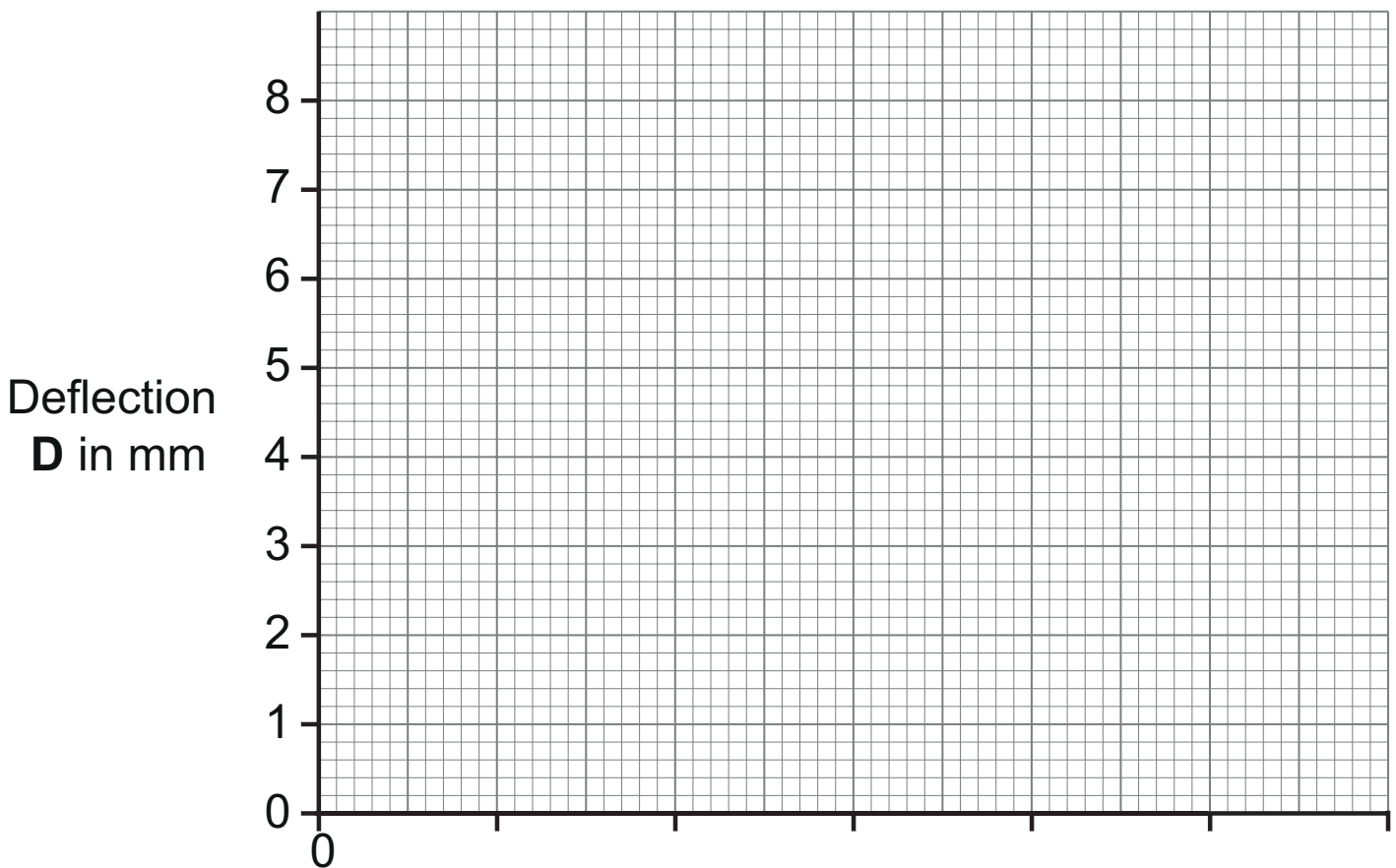

- (b) Draw a line of best fit. [1]

(c) (i) Use your graph to determine the constant k , in **Equation 3.1**.

Remember to include the unit for k . [4]

$k =$ _____ : Unit = _____

(ii) Use your graph to find the deflection for a mass of 125 g. [1]

Deflection = _____ mm

4 The diagram shows a playground roundabout.

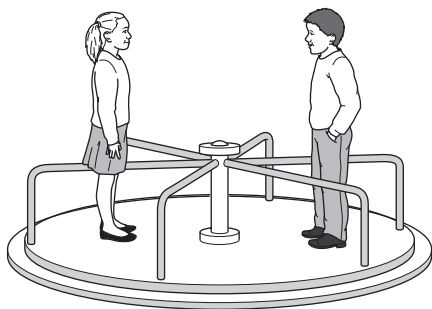

Holly and Brian stand the same distance from the centre of a revolving roundabout.

Brian has a mass of 35 kg and Holly a mass of 20 kg.

(a) (i) How does the centripetal force acting on Brian compare with that acting on Holly? [1]

Place a tick (✓) in the correct box.

The centripetal force acting on Brian is:

greater than that acting on Holly.

equal to that acting on Holly.

less than that acting on Holly.

Brian now stands at the outer edge of the roundabout where his radius is larger. However, his speed is the same as it was in part (i).

(ii) How does the centripetal force acting on Brian now compare with that in part (i)? [1]

Place a tick (✓) in the correct box.

The centripetal force acting on Brian is:

greater than in part (i).

equal to that in part (i).

less than that in part (i).

(b) At a given instant Holly is travelling with a velocity of 0.75 m/s. Calculate her momentum in kg m/s. Remember Holly's mass is 20 kg. [3]

You are advised to show your working out.

Momentum = _____ kg m/s

- 5 Mary and Neil run towards each other. Mary runs with a constant speed of 3 m/s and Neil with a constant speed of 2 m/s.

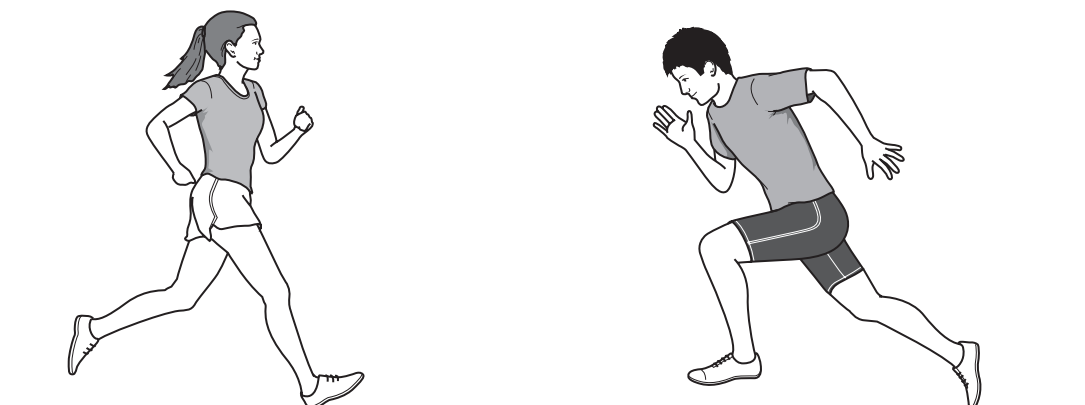

Mary's velocity–time graph is shown below.

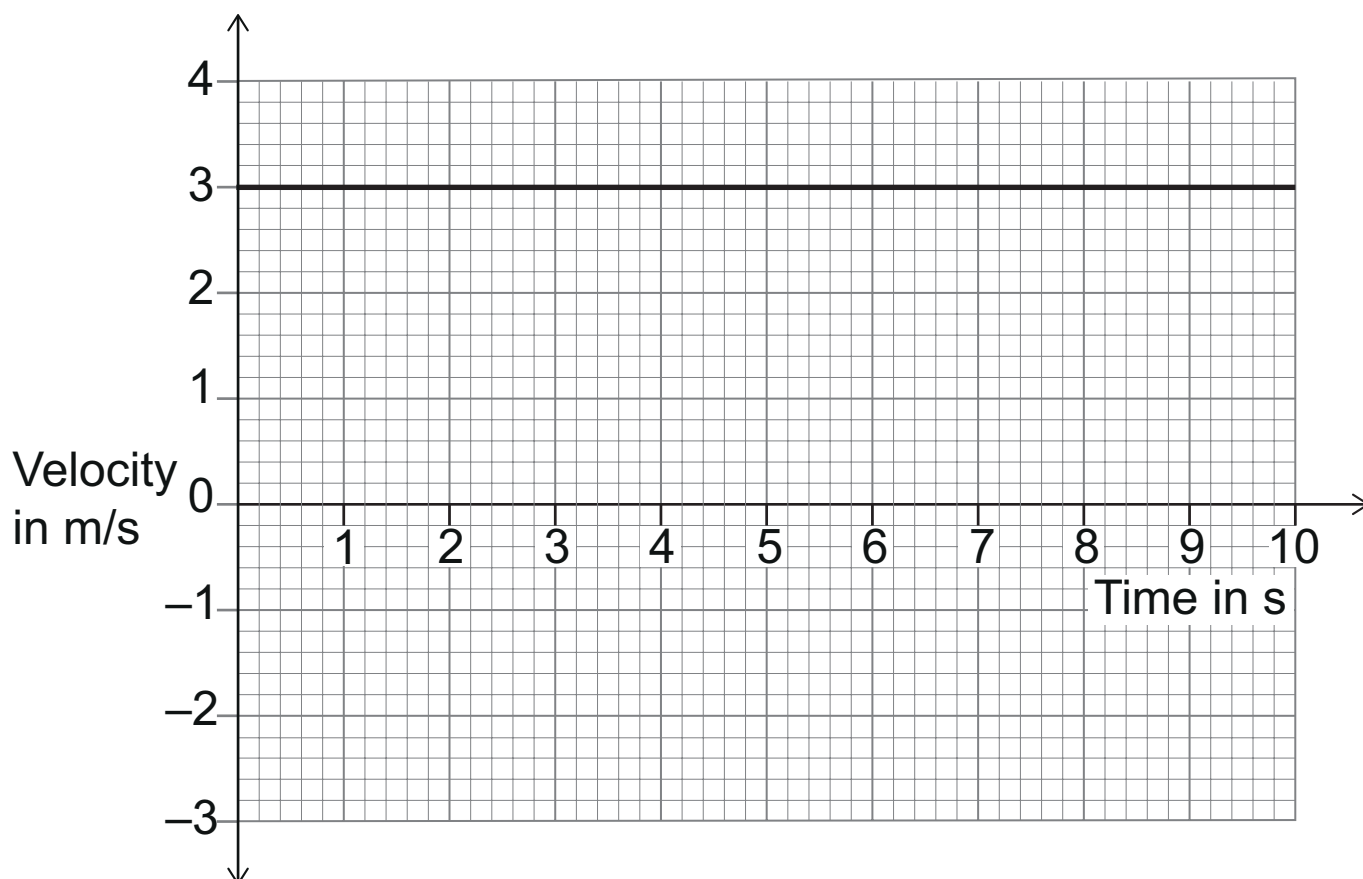

- (a) (i) Draw Neil's velocity–time graph on the axes on page 12 opposite. [2]

The runners pass each other when Mary has run a distance of 21 m.

- (ii) At what time do they pass? [3]

You are advised to show your working out.

Time = _____ s

On another occasion Mary's velocity–time graph is as shown below.

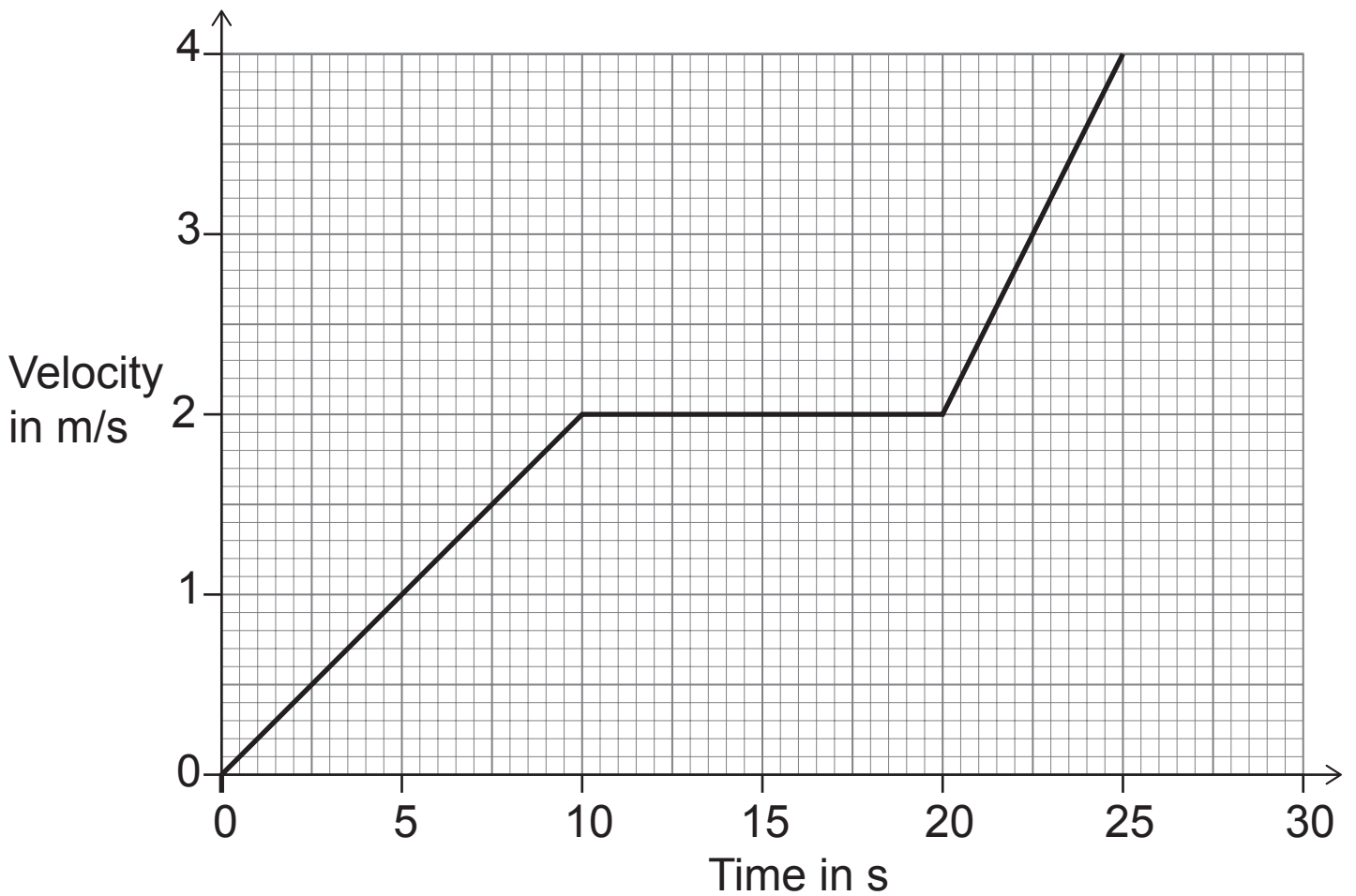

(b) Use the graph to find Mary's **maximum** acceleration. [4]

You are advised to show your working out.

Maximum acceleration = _____ m/s²

6 Nuclear fusion is an energy source.

(a) Where, in our solar system, does fusion occur naturally?
[1]

This part of the question is about a nuclear disintegration involving alpha decay.

(b) Uranium undergoes alpha (α) decay to Thorium. [4]

Complete a balanced nuclear equation for this reaction.

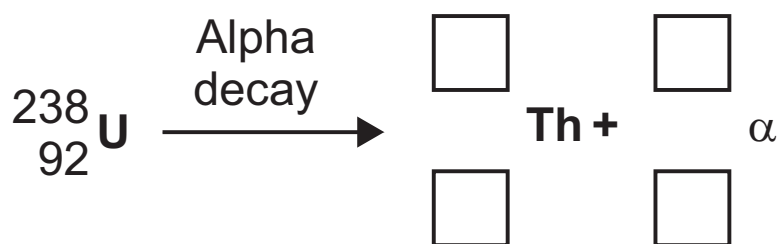

7 Write an account on background radiation. Your account should make reference to the following:

- what background radiation is,
- two sources of background radiation,
- how it is measured in the laboratory,
- how it is taken into account when measuring the count rate of another radioactive source. [6]

In this question you will be assessed on your written communication skills including the use of specialist scientific terms.

BLANK PAGE

(Questions continue overleaf)

8 (i) State the Principle of Moments. [2]

Donal places a uniform piece of wood of mass 120 g on a table and keeps it from falling off the table by pressing down as shown.

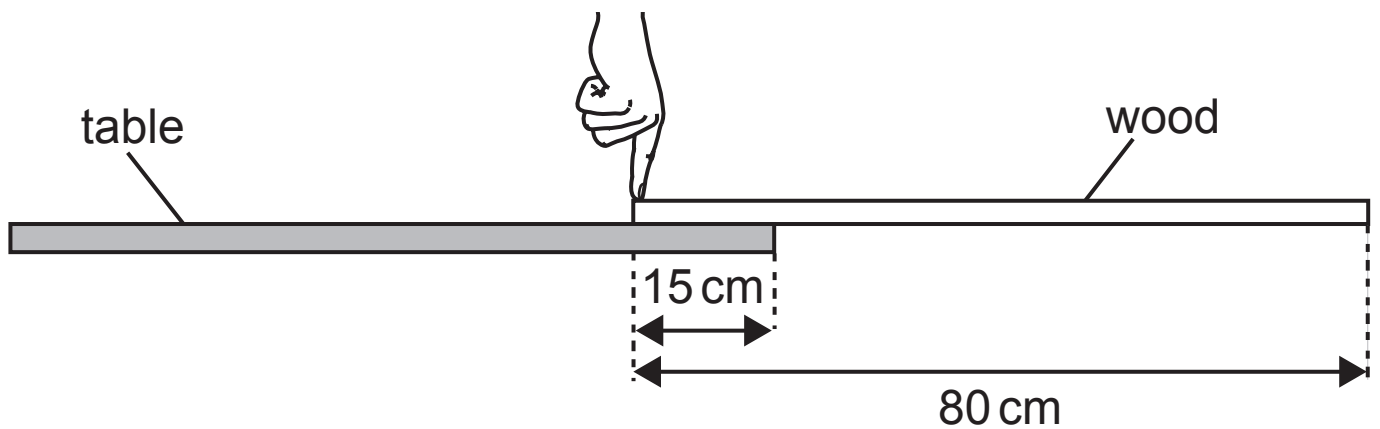

(ii) Draw an arrow, acting from the correct point, to show the direction of the weight of the piece of wood. Label this arrow with the weight of the wood, in N. [2]

(iii) Calculate the moment of the weight of the wood, in Ncm, about the right edge of the table. [3]

You are advised to show your working out.

Moment = _____ Ncm

(iv) Calculate the downward force Donal exerts. [2]

You are advised to show your working out.

Force = _____ N

- 9 A bullet is fired into a piece of wood in a forensic testing laboratory.

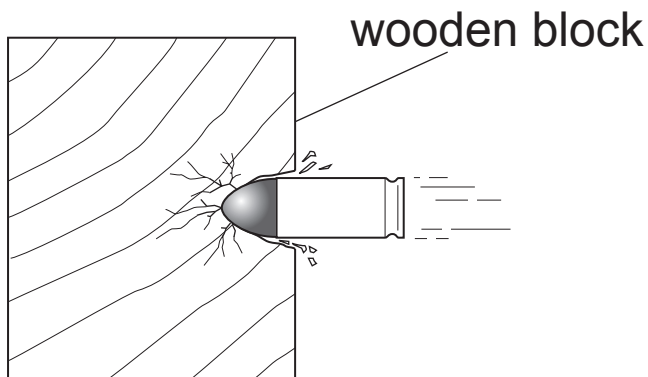

The average resistive force acting on the bullet as it becomes embedded in the wood is 1960 N. The bullet stops a distance of 15.0 cm into the wood.

- (i) Show that the work done in stopping the bullet is 294 J.
[2]

You are advised to show your working out.

- (ii) The bullet has a mass of 0.03 kg. Calculate the entry velocity of the bullet. Ignore energy losses. [4]

You are advised to show your working out.

Velocity = _____ m/s

THIS IS THE END OF THE QUESTION PAPER

For Examiner's use only	
Question Number	Marks
1	
2	
3	
4	
5	
6	
7	
8	
9	
Total Marks	

Permission to reproduce all copyright material has been applied for.
In some cases, efforts to contact copyright holders may have been unsuccessful and CCEA will be happy to rectify any omissions of acknowledgement in future if notified.