



Centre Number

| | |
|----|--|
| 71 | |
|----|--|

Candidate Number

| |
|--|
| |
|--|

General Certificate of Secondary Education
2012

Science: Double Award (Non-Modular)

Paper 3
Higher Tier

[G8406]



FRIDAY 15 JUNE, AFTERNOON

TIME

1 hour 45 minutes.

INSTRUCTIONS TO CANDIDATES

Write your Centre Number and Candidate Number in the spaces provided at the top of this page.
Write your answers in the spaces provided in this question paper.
Answer **all twelve** questions.

INFORMATION FOR CANDIDATES

The total mark for this paper is 120.
Quality of written communication will be assessed in question **11(a)(i)**.
Figures in brackets printed down the right-hand side of pages indicate the marks awarded to each question or part question.
Details of calculations should be shown.
Units must be stated in numerical answers where appropriate.

| For Examiner's use only | |
|-------------------------|-------|
| Question Number | Marks |
| 1 | |
| 2 | |
| 3 | |
| 4 | |
| 5 | |
| 6 | |
| 7 | |
| 8 | |
| 9 | |
| 10 | |
| 11 | |
| 12 | |

| | |
|--------------------|--|
| Total Marks | |
|--------------------|--|



1 Two men pull a roller over a football pitch.



The diagram below represents the forces that are exerted.

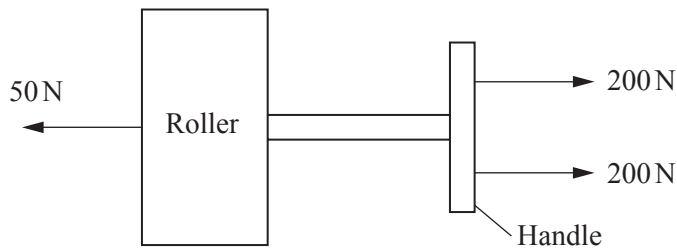

The men exert a force of 200 N each and the opposing forces add up to 50 N.

Calculate the acceleration of the roller if its mass is 500 kg.

You are advised to show your working out.

Acceleration = _____ m/s² [4]

| Examiner Only | |
|---------------|--------|
| Marks | Remark |
| ○ | ○ |

2 A train travels on a short journey from rest.

The train reaches a velocity of 8 m/s after 10 seconds.

It travels at a constant velocity of 8 m/s for another 40 seconds and then decelerates uniformly to rest in a further 20 seconds.

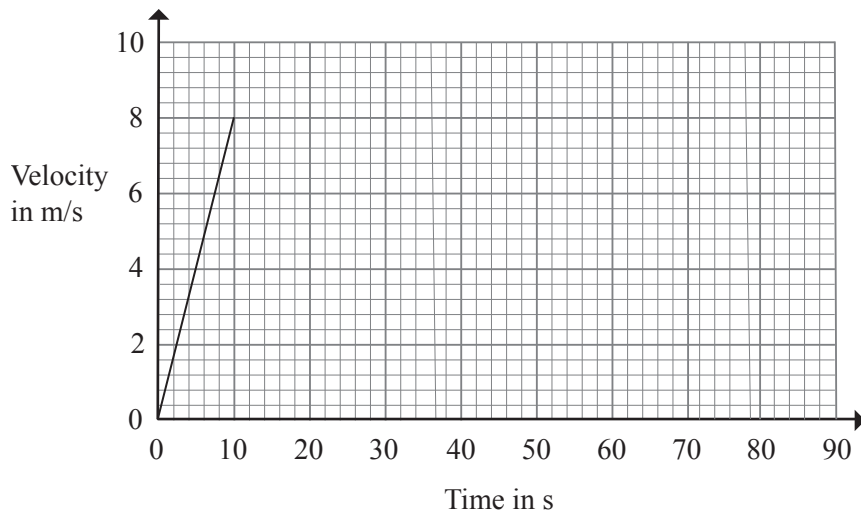

- (i) Part of the graph has been drawn for you. Complete the graph for the journey. [2]
- (ii) Calculate the acceleration of the train during the first 10 seconds of its journey.

You are advised to show your working out.

Acceleration = _____ m/s² [3]

| Examiner Only | |
|---------------|--------|
| Marks | Remark |
| ○ | ○ |

- 3 The diagram shows two satellites A and B orbiting the Earth on the same circular path and in the same direction.

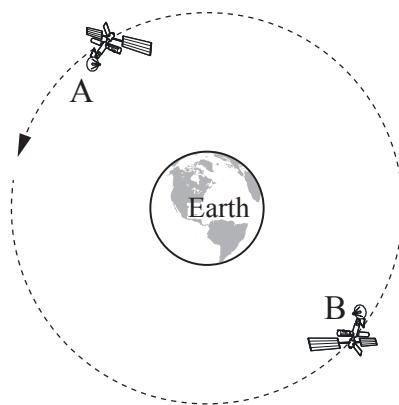

- (a) Draw an arrow on satellite A to show the direction of the force acting on it due to the Earth. [1]
- (b) Satellite B has a greater mass than satellite A. How does the force on satellite A compare with the force on satellite B?

Tick (✓) the correct answer.

| | |
|--|--|
| The force on A is greater than the force on B. | |
| The force on A is equal to the force on B. | |
| The force on A is less than the force on B. | |

[1]

- (c) Name the force on the satellites which keeps them moving in a circle.

_____ [1]

- (d) The radius of satellite A's orbit is reduced. How will this affect the force between satellite A and the Earth?

Tick (✓) the correct answer.

| | |
|--------------------------------------|--|
| The force on A will decrease. | |
| The force on A will remain the same. | |
| The force on A will increase. | |

[1]

- (e) Draw an arrow on satellite B to show the direction of its velocity. [1]

| Examiner Only | |
|---------------|--------|
| Marks | Remark |
| ○ | ○ |

4 The Sun is a star.

(a) What is the name given to a collection of stars?

_____ [1]

(b) There are four stages in the formation of a star.

Use the numbers 1, 3 and 4 to complete the order in which the stages occur.

| | |
|--|---|
| Gas ball begins to spin | 2 |
| Hydrogen particles are pulled together by gravitational forces | |
| The star generates energy | |
| The temperature rises | |

[2]

(c) State two types of radiation emitted by a star.

1. _____

2. _____ [2]

| Examiner Only | |
|---------------|--------|
| Marks | Remark |
| ○ | ○ |

5 The Big Bang theory explains the origin and expansion of the universe.

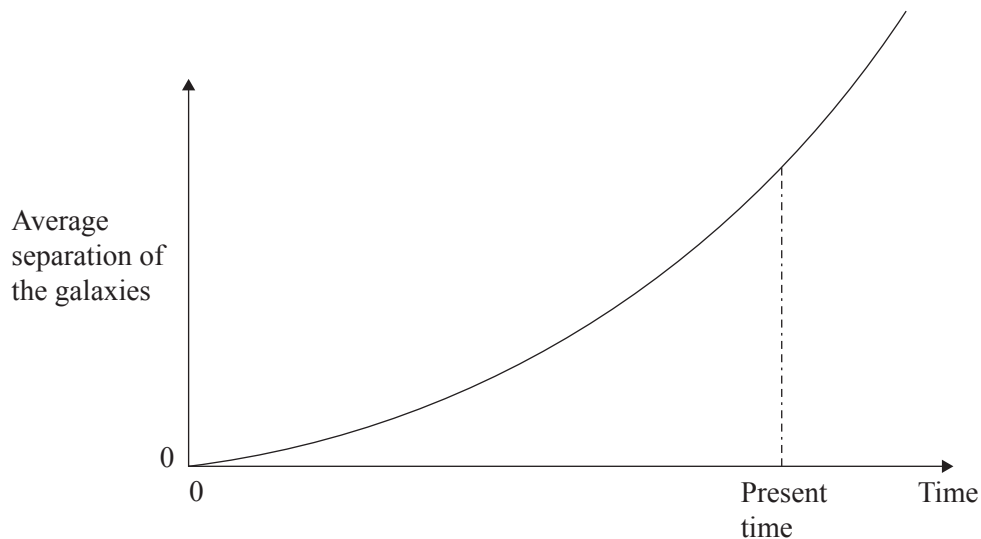

The graph above shows how the average separation of the galaxies has increased over time, according to the Big Bang theory.

(a) What other feature of the graph supports the Big Bang theory?

_____ [1]

(b) Name the other scientific theory which attempts to explain the origin of the universe.

_____ [1]

(c) State two reasons, not related to cost, why it is difficult to send a manned spacecraft to another planet outside our solar system.

1. _____

2. _____ [2]

(d) What nuclear process in stars generates energy?

_____ [1]

| Examiner Only | |
|---------------|--------|
| Marks | Remark |
| ○ | ○ |

6 (a) State the Principle of Moments.

[2]

(b) The bonnet of a truck is held in a horizontal position by a support rod.

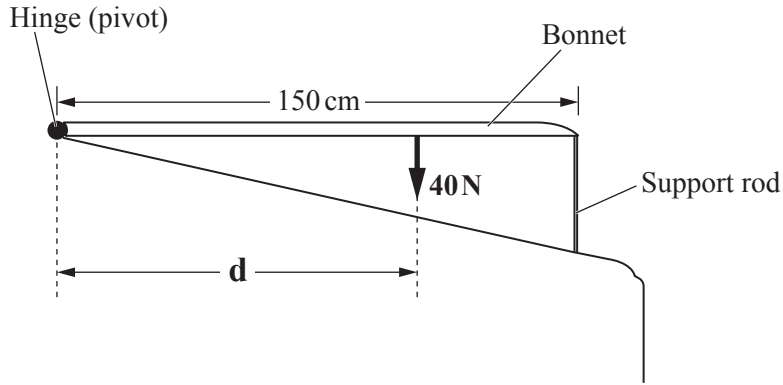

The support rod exerts an upward force of 24 N and the bonnet has a weight of 40 N. Calculate the distance d of the centre of gravity of the bonnet from the hinge.

You are advised to show your working out.

Distance = _____ cm [4]

| Examiner Only | |
|---------------|--------|
| Marks | Remark |
| ○ | ○ |

- 7 An experiment on heat transfer is carried out in the laboratory. A metal ball is heated until it is red hot and then suspended as shown.

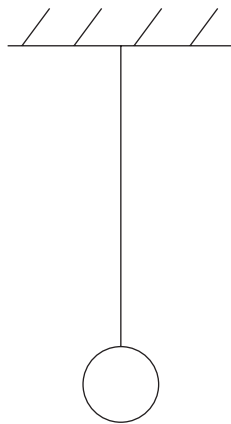

- (a) Which one of the following statements is correct?

Tick (✓) the correct box.

We see both the infrared and the red light.

We feel the infrared and see the red light.

We feel both the infrared and the red light.

[1]

Two heat sensors are placed at equal distances from the red hot ball as shown below.

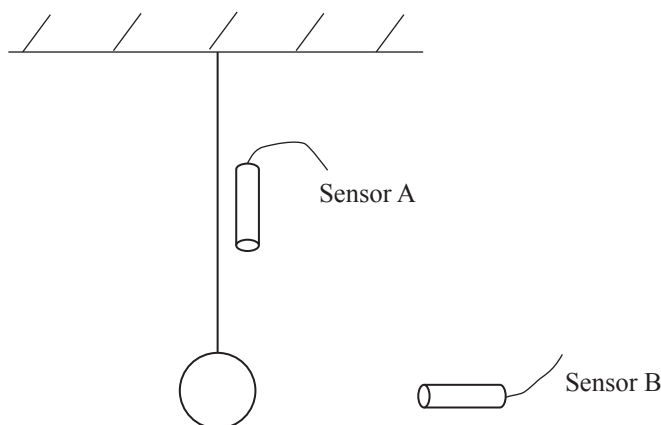

- (b) Explain fully why sensor A gives a higher reading than sensor B.

[2]

| Examiner Only | |
|---------------|--------|
| Marks | Remark |
| ○ | ○ |

(c) The experiment is now repeated but this time the apparatus is placed in a vacuum.

(i) How does the reading of sensor A now compare with the reading of sensor B?

_____ [1]

(ii) Explain your answer.

_____ [1]

| Examiner Only | |
|---------------|--------|
| Marks | Remark |
| | |

8 A hammer is used to drive a stake into the ground.

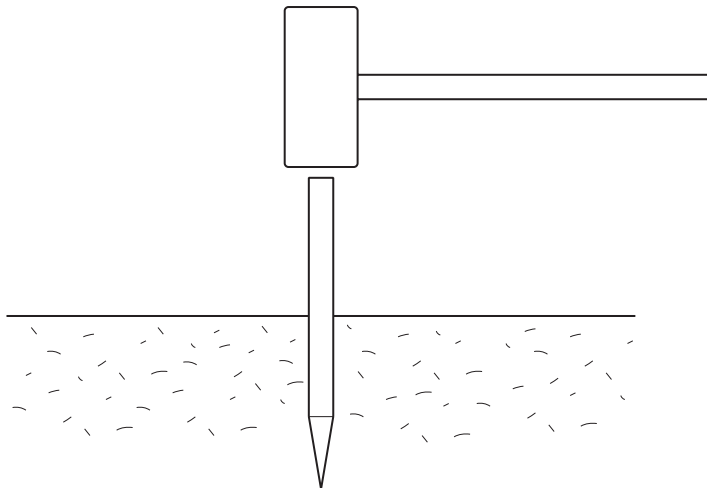

One strike of the hammer drives the stake a distance of 0.2 m into the ground. The average resistance force exerted by the ground is 320 N.

(i) Show that the work done on the stake is 64 J.

[2]

(ii) Assume that the kinetic energy of the hammer is 64 J at the point of impact and that the mass of the hammer is 0.5 kg.

Calculate the velocity of the hammer at impact.

You are advised to show your working out

Velocity = _____ m/s [3]

| Examiner Only | |
|----------------------|----------------------|
| Marks | Remark |
| <input type="text"/> | <input type="text"/> |

9 (a) Shauna uses a stretched slinky to make longitudinal waves.

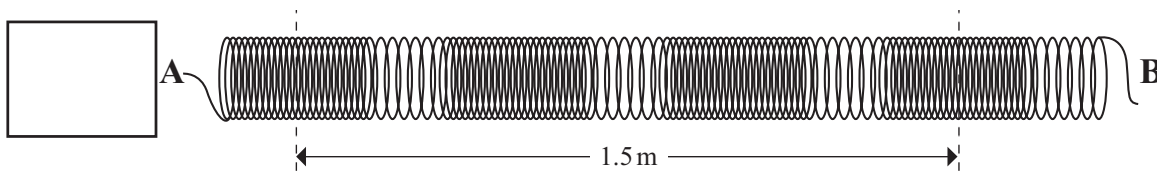

| Examiner Only | |
|---------------|--------|
| Marks | Remark |
| ○ | ○ |

(i) What do the longitudinal waves transfer from **A** to **B**?

_____ [1]

(ii) In the box, draw a double-headed arrow to indicate the direction Shauna would have to move end **A** to make longitudinal waves. [1]

(iii) Shauna sends 18 waves along the slinky in 6 seconds.
How many waves does she make in 1 second?

_____ [1]

(iv) Use your answer to part (iii) to state the frequency of the waves.

Frequency = _____ Hz [1]

(v) What is the wavelength of the longitudinal waves?

Wavelength = _____ m [1]

(vi) Use your answers to parts (iv) and (v) to calculate the speed of the longitudinal waves.

You are advised to show your working out.

Speed = _____ m/s [3]

(vii) Give another example of a longitudinal wave.

_____ [1]

10 (a) (i) Indicate with a tick (✓) on the table below whether the object is luminous or non-luminous.

| Object | Luminous | Non-luminous |
|-------------|----------|--------------|
| Star | | |
| Moon | | |
| Planet | | |
| White paper | | |

[4]

The diagram below shows a shadow of a ball being formed on a screen by a point source of light.

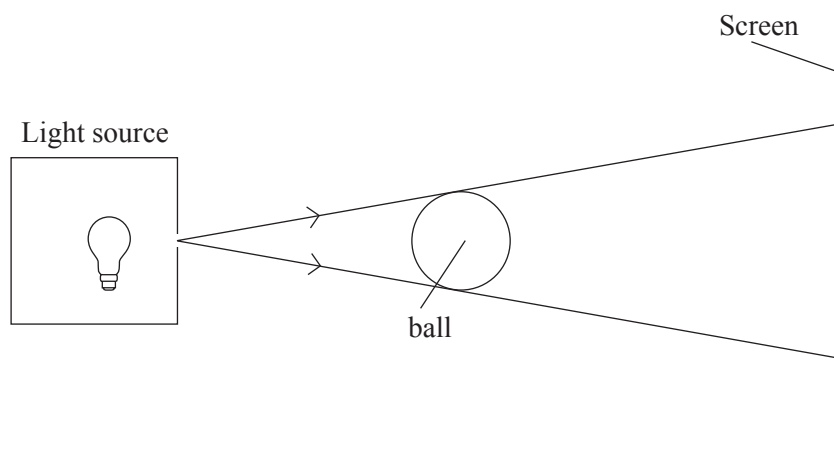

(ii) Which statement below best describes the shadow formed on the screen?

- A The shadow is uniformly black.
- B The shadow contains partial shadow AND uniformly black shadow.
- C The entire shadow is partial shadow.

Answer _____ [1]

| Examiner Only | |
|---------------|--------|
| Marks | Remark |
| ○ | ○ |

A ray of light is incident on a plane mirror as shown.

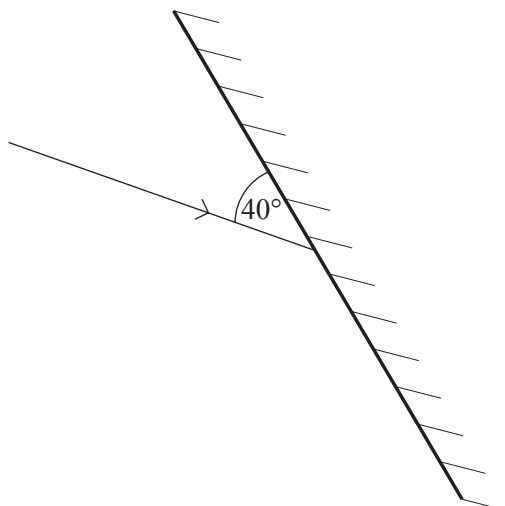

(b) (i) Draw and label the normal. [1]

(ii) What size is the angle of reflection?

Angle of reflection = _____ ° [1]

Different shapes of glass prism are often used to change the direction of light rays.

(c) (i) Continue the path of the ray shown until it emerges into the air.

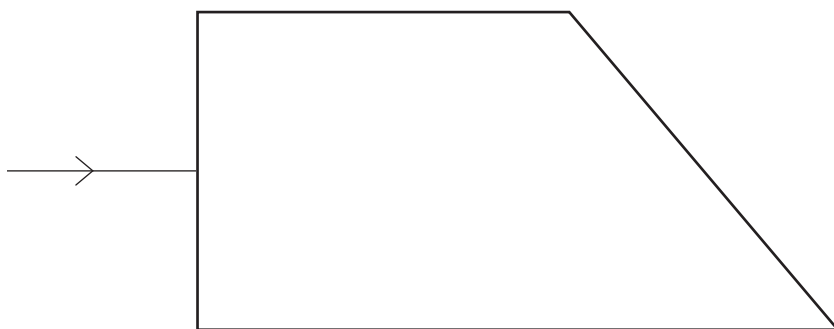

[3]

(ii) Does the speed of light increase, decrease or remain the same as it enters the glass?

_____ [1]

| Examiner Only | |
|---------------|--------|
| Marks | Remark |
| | |

11 (a) James was wearing a woollen sweater and a nylon shirt. When he removes the sweater he sees a spark.



(i) Explain fully in terms of charge movement how the sweater became charged.

_____ [2]

Quality of written communication [1]

When two charged sweaters (A and B) were suspended on threads they moved apart as shown below.

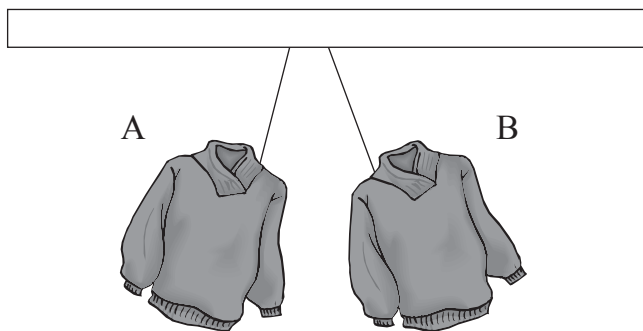

(ii) What does this indicate about the charges on the sweaters?

_____ [1]

(iii) Explain your answer to part (ii).

_____ [1]

| Examiner Only | |
|---------------|--------|
| Marks | Remark |
| ○ | ○ |

- (b) A charge of 0.6 C is transferred from a charged sweater through a conductor in 0.2 seconds.

What current flows through the conductor?

You are advised to show your working out.

Current = _____ A [3]

- (c) Three $20\ \Omega$ resistors are connected as shown below.

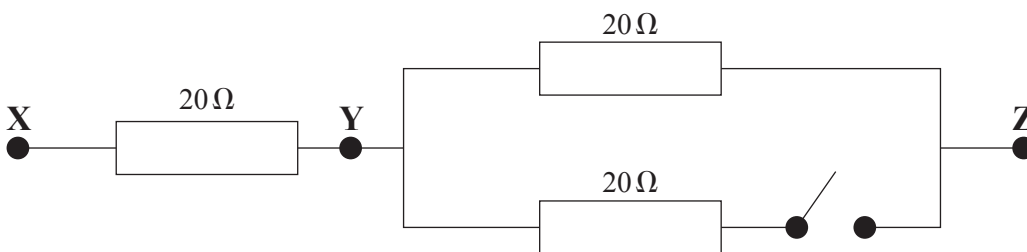

Complete the following table to show the total resistance between the different points for the switch settings indicated.

| Points | Switch | Resistance in Ω |
|---------|--------|------------------------|
| Y and Z | Closed | |
| X and Z | Open | |
| X and Z | Closed | |

[3]

Examiner Only

Marks Remark

- (d) A pupil investigates the variation of current with voltage for a resistor. The results are given below.

| | | | | | | |
|---------------|---|-----|-----|-----|-----|-----|
| Voltage in V | 0 | 0.8 | 1.2 | 1.8 | 2.0 | 2.8 |
| Current in mA | 0 | 20 | 30 | 40 | 50 | 70 |

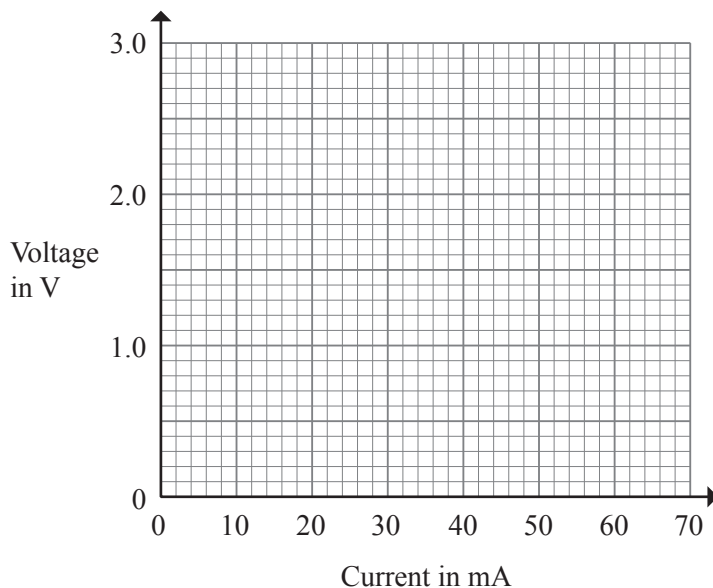

(i) Plot the points on the grid. [1]

(ii) Draw the best fit straight line through the points. [1]

(iii) Use your graph to find the voltage when the current is 60 mA

Voltage = _____ V [1]

(iv) Convert 60 mA to A. Remember 1 mA = 0.001 A

Current = _____ A [1]

| Examiner Only | |
|---------------|--------|
| Marks | Remark |
| | |

12 The diagram shows the wiring in an electrical plug.

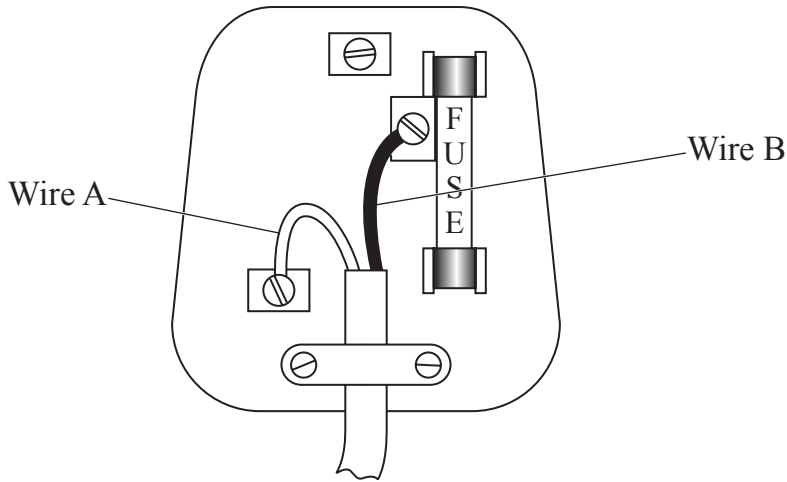

(a) (i) Which terminal has no wire connected?

_____ [1]

Identify the two wires, A and B, and give their colours.

(ii) Wire A is the _____ wire and it is a _____ colour. [1]

(iii) Wire B is the _____ wire and it is a _____ colour. [1]

(iv) Why is the fuse connected to wire B in the plug?

_____ [1]

When the plug shown above is connected to a hairdryer, it is still safe for use.

(v) What property of the hairdryer makes this possible?

_____ [1]

| Examiner Only | |
|---------------|--------|
| Marks | Remark |
| ○ | ○ |

When a **three core** electrical cable passes through the metal body of an electrical appliance a rubber ring (grommet) is inserted in the entry hole. This is done as a precaution to protect the cable from the sharp edge of the hole.

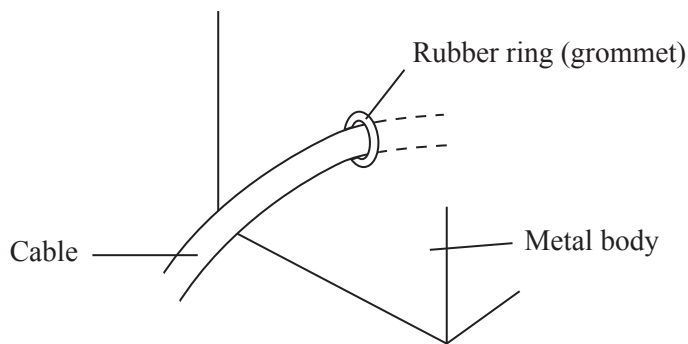

With use this grommet can wear away and the edge of the metal body can cut through the insulation in the electric cable.

(b) (i) What makes this dangerous?

_____ [1]

(ii) Explain fully how earthing reduces the danger.

 _____ [3]

| Examiner Only | |
|---------------|--------|
| Marks | Remark |
| | |

A coil of wire is connected to a very sensitive ammeter and a magnet is at rest inside the coil.

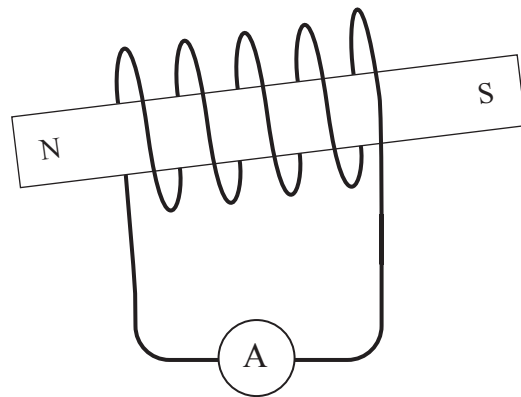

(c) (i) Why does no current flow in the coil?

_____ [1]

Another arrangement is shown below. No current flows in Circuit Y.

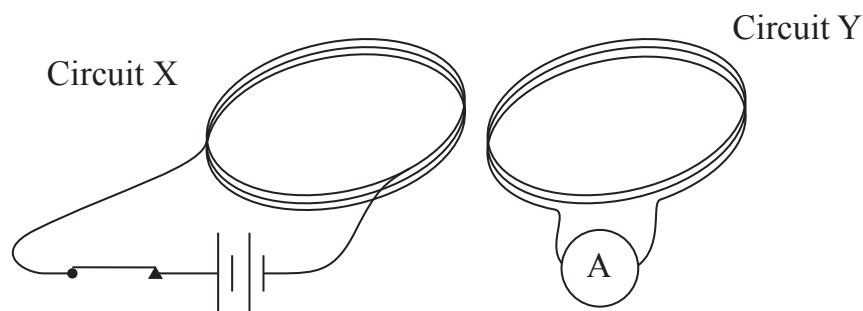

(ii) State three practical ways that a current can be induced in Circuit Y.

1. _____
2. _____
3. _____ [3]

| Examiner Only | |
|---------------|--------|
| Marks | Remark |
| | |

Permission to reproduce all copyright material has been applied for.
In some cases, efforts to contact copyright holders may have been unsuccessful and CCEA
will be happy to rectify any omissions of acknowledgement in future if notified.