



Centre Number

71

Candidate Number

General Certificate of Secondary Education
2011–2012

Science: Double Award (Modular)

Forces and Energy

End of Module Test

Higher Tier

[GDC02]

C

MONDAY 14 NOVEMBER 2011

1.30 pm–2.15 pm



TIME

45 minutes.

INSTRUCTIONS TO CANDIDATES

Write your Centre Number and Candidate Number in the spaces provided at the top of this page.

Write your answers in the spaces provided in this question paper. Answer **all twelve** questions.

INFORMATION FOR CANDIDATES

The total mark for this paper is 50.

Figures in brackets printed down the right-hand side of pages indicate the marks awarded to each question or part question.

For Examiner's
use only

Question Number	Marks
1	
2	
3	
4	
5	
6	
7	
8	
9	
10	
11	
12	

Total
Marks



- 1 An electric drill uses 800 J of electrical energy. 200 J of this energy is turned into heat and sound.

Calculate the efficiency of the electric drill.

You are advised to show your working out.

Efficiency = _____ [3]

Examiner Only	
Marks	Remark
○	○

2 A loudspeaker sits on a floor.

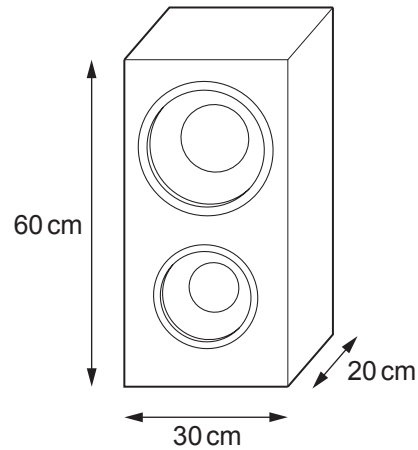

(i) Calculate the base area of the loudspeaker, in cm^2 .

Area = _____ cm^2 [1]

(ii) The weight of the loudspeaker is 200 N. Use your answer to part (i) to calculate the pressure it exerts on the floor, in N/cm^2 .

You are advised to show your working out.

Pressure = _____ N/cm^2 [3]

Examiner Only	
Marks	Remark
○	○

3 A satellite orbits the earth. Four directions are shown on the satellite.

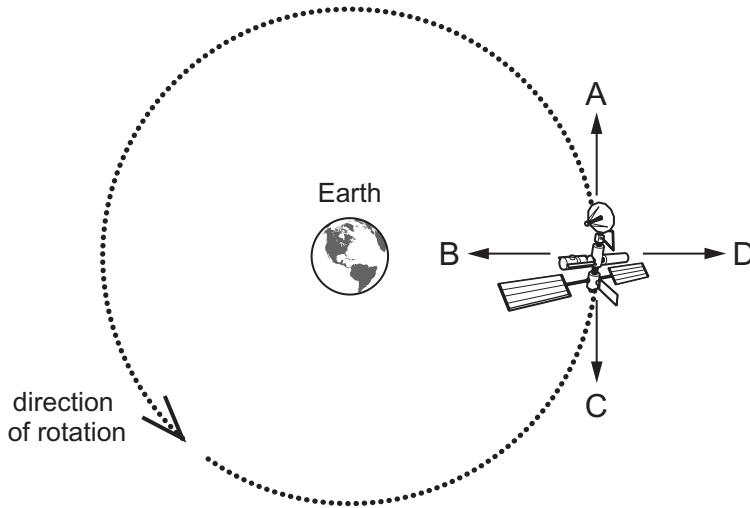

(a) (i) Which letter gives the direction of the force which keeps the satellite moving in a circular orbit?

Letter _____ [1]

(ii) Which letter gives the direction of the weight of the satellite?

Letter _____ [1]

(b) The mass of the satellite is 160 kg and it is moving at a steady speed of 2000 m/s. Calculate the satellite's momentum.

You are advised to show your working out.

Momentum = _____ kg m/s [3]

Examiner Only	
Marks	Remark
○	○

4 (a) State Hooke's Law.

[2]

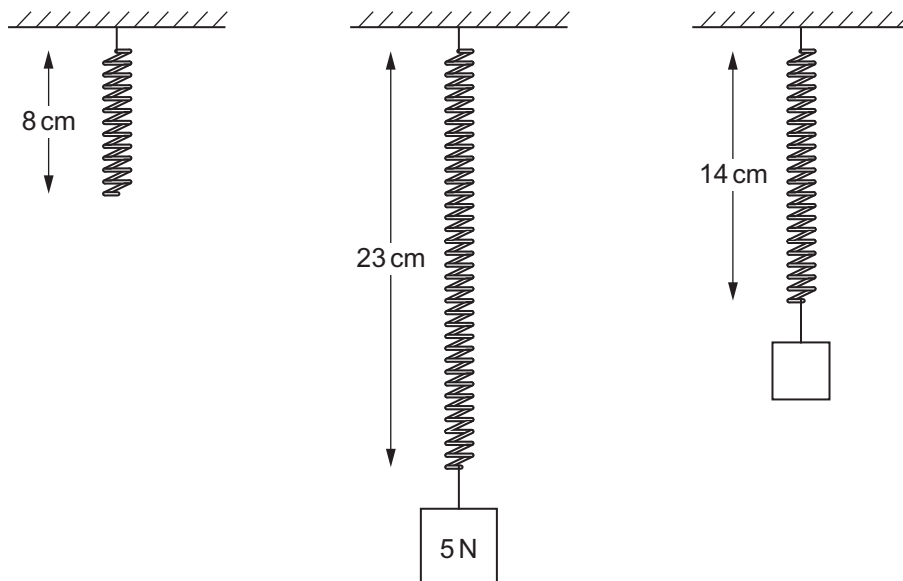

(b) A spring has a natural length of 8 cm. When loaded with a 5 N weight the total length of the spring is 23 cm. What weight would extend the spring so that its total length is 14 cm?

You are advised to show your working out.

Weight = _____ N [3]

Examiner Only	
Marks	Remark
○	○

5 Heat energy can be transferred from one point to another by different methods.

Listed below are a number of different statements. After each statement write down the name of the relevant method of heat transfer.

Involves vibrating atoms. _____

Does not require a medium. _____

Involves electrons colliding with atoms. _____

Involves movement of atoms from one place to another. _____

[4]

Examiner Only	
Marks	Remark
○	○

6 Flora walks to school and her distance–time graph is shown.

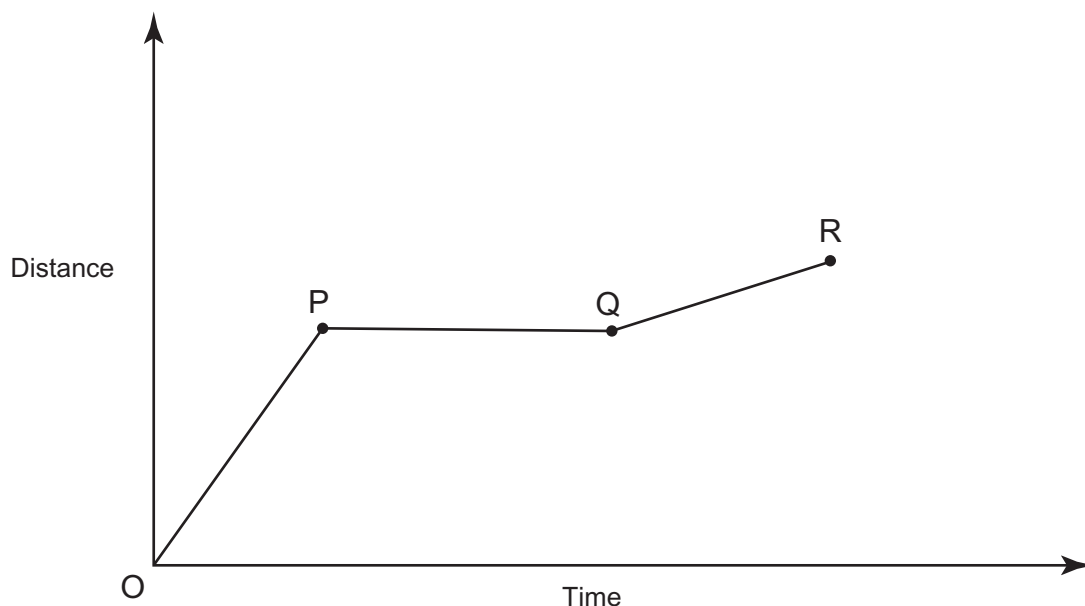

(a) During which part of the journey does Flora walk fastest?

_____ [1]

A number of statements are made below.

(b) Tick (✓) **two** correct statements which refer to Flora's walk.

Flora stops walking during PQ.

The distance to Flora's school is given by the area under the graph.

Flora's speed is increasing during OP.

Flora's speed during QR could be found by calculating the gradient of QR.

Flora walks slower during OP than during QR.

[2]

(c) Distance and displacement are both measured in metres. What is the difference between distance and displacement?

_____ [1]

Examiner Only	
Marks	Remark
○	○

- 7 A ball of mass 1.5 kg falls through the air and the resistive forces acting on it add up to 3 N.

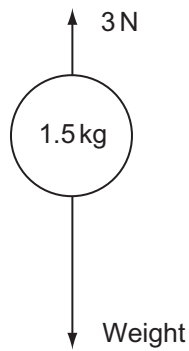

- (i) By first finding the resultant force, calculate the acceleration of the ball.

You are advised to show your working out.

Acceleration = _____ m/s^2 [3]

- (ii) The acceleration due to gravity is 10 m/s^2 . Why is your answer to part (i) not equal to 10 m/s^2 ?

_____ [1]

Examiner Only	
Marks	Remark
○	○

- 8 An electric motor is rated at 6000W. In order to raise a load the motor does 36 000 J of work.

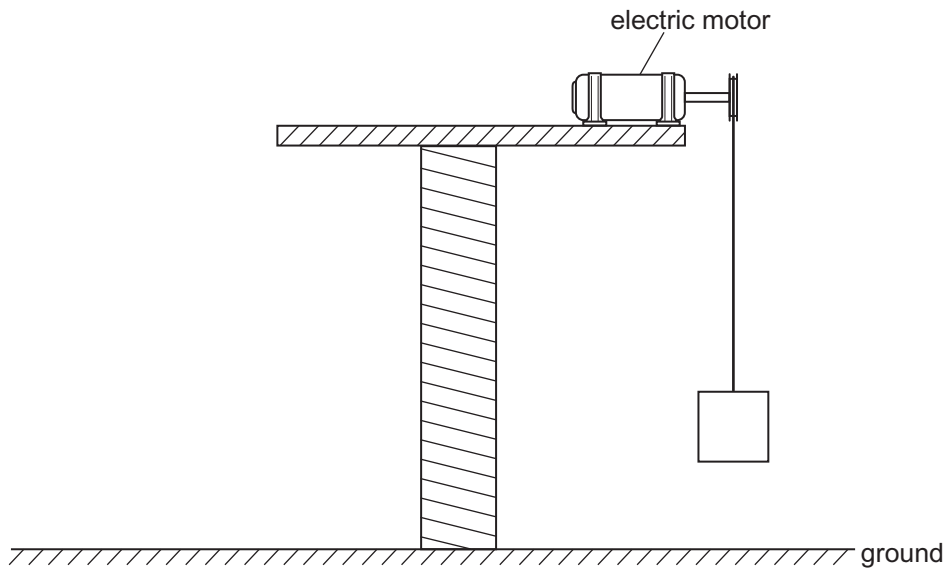

Calculate how long it takes the motor to raise the load.

You are advised to show your working out.

Time = _____ s [3]

Examiner Only	
Marks	Remark
<input type="text"/>	<input type="text"/>

9 Roy shoots an arrow vertically into the air.



The arrow has an initial kinetic energy of 30 J.

- (i) How much **kinetic** energy does the arrow have when it reaches its maximum height?

Kinetic energy = _____ J [1]

The arrow loses **one sixth** of its initial energy during its upward flight.

- (ii) How much energy does the arrow have at its maximum height?

Energy = _____ J [1]

The arrow has a mass of 0.2 kg.

- (iii) Calculate the maximum height of the arrow.

You are advised to show your working out.

Height = _____ m [3]

Examiner Only	
Marks	Remark
○	○

10 Many scientists believe that Great Britain will have to increase the amount of electricity it produces by nuclear power.

(a) Give an advantage, not related to cost, of generating electricity using a nuclear power station.

_____ [1]

All power stations are decommissioned at the end of their working life.

(b) Explain fully what decommissioning means.

_____ [2]

Examiner Only	
Marks	Remark
○	○

11 Donal runs a race and the velocity–time graph for the race is shown below.

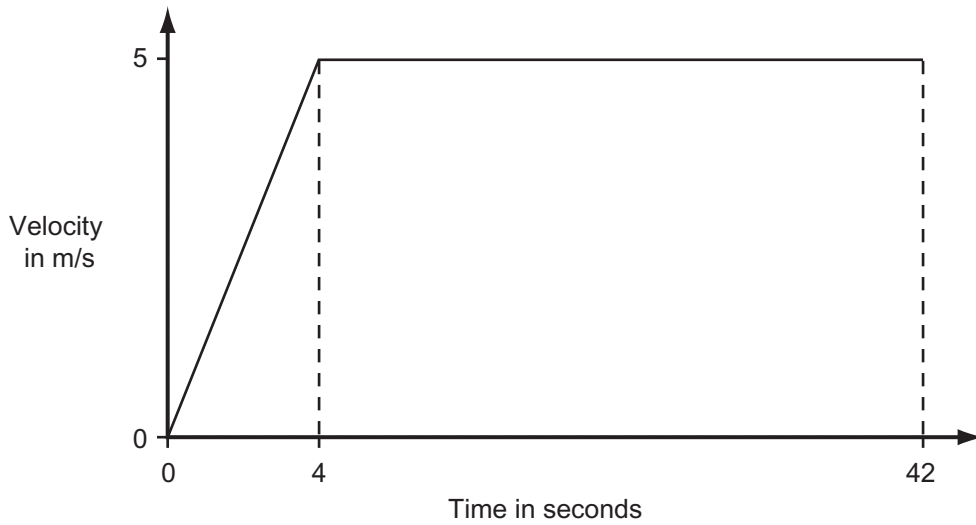

Donal finishes the race after 42 seconds.

(i) What was the length of the race that Donal had entered?

You are advised to show your working out.

Length of race = _____ m [4]

(ii) What was Donal's acceleration during the first 4 seconds of the race.

You are advised to show your working out.

Acceleration = _____ m/s² [3]

Examiner Only	
Marks	Remark
○	○

12 Kevin lifts a wheelbarrow of soil.

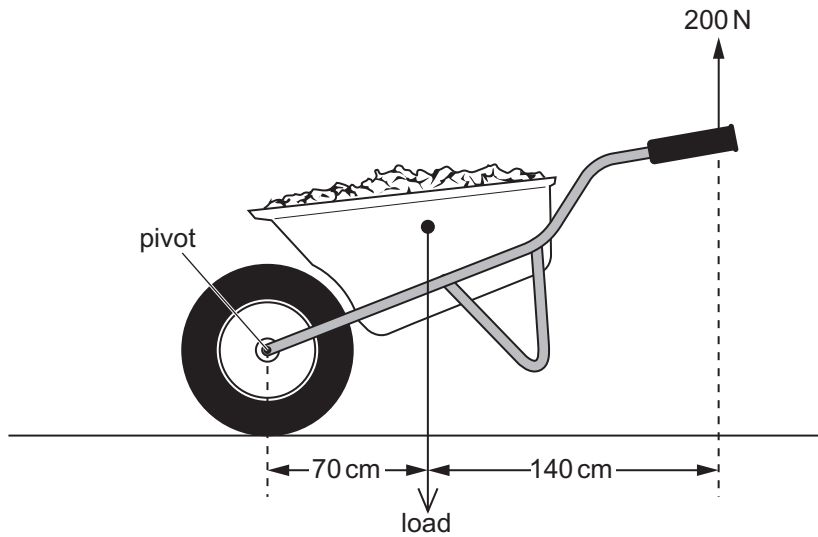

Kevin exerts an upward force of 200 N on the wheelbarrow. Use the principle of moments to find the maximum load he can lift.

You are advised to show your working out.

Maximum load = _____ N [3]

THIS IS THE END OF THE QUESTION PAPER

Examiner Only	
Marks	Remark
○	○

Permission to reproduce all copyright material has been applied for.
In some cases, efforts to contact copyright holders may have been unsuccessful and CCEA
will be happy to rectify any omissions of acknowledgement in future if notified.