



Centre Number

71

Candidate Number

General Certificate of Secondary Education
2011–2012

Science: Double Award (Modular)

Forces and Energy

End of Module Test

Foundation Tier

C

[GDC01]

MONDAY 14 NOVEMBER 2011

1.30 pm–2.15 pm



TIME

45 minutes.

INSTRUCTIONS TO CANDIDATES

Write your Centre Number and Candidate Number in the spaces provided at the top of this page.

Write your answers in the spaces provided in this question paper. Answer **all twelve** questions.

INFORMATION FOR CANDIDATES

The total mark for this paper is 50.

Figures in brackets printed down the right-hand side of pages indicate the marks awarded to each question or part question.

For Examiner's
use only

Question Number	Marks
1	
2	
3	
4	
5	
6	
7	
8	
9	
10	
11	
12	

Total
Marks



1 (a) Name the main type of energy in the following:

(i) a bowl of cornflakes

_____ energy [1]

(ii) a wound up spring in a toy

_____ energy [1]

(iii) the energy from a loudspeaker



© Adrian Pingstone

_____ energy [1]

(b) A ball moving through the air has two types of energy. What are they?

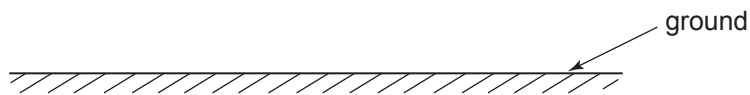

_____ energy and _____ energy [2]

Examiner Only	
Marks	Remark
○	○

2 (a) Explain what is meant by a renewable energy resource.

_____ [1]

(b) For each energy resource below place a tick (✓) to indicate whether the resource is renewable or non-renewable.

Energy resource	Renewable	Non-renewable
Coal		
Wind		
Nuclear		
Gas		

[4]

3 There has been a big increase in the amount of the most important greenhouse gas in recent times.

(a) State the name of this greenhouse gas.

_____ [1]





(b) How is most of this greenhouse gas produced?

_____ [1]

Scientists believe that an increase in greenhouse gas will lead to a rise in temperature of the atmosphere.

(c) What environmental harm will this cause?

_____ [1]

Examiner Only	
Marks	Remark
	
	

4 (a) Explain fully what is meant by the word friction.

[2]

Benjamin skis down a snow slope.

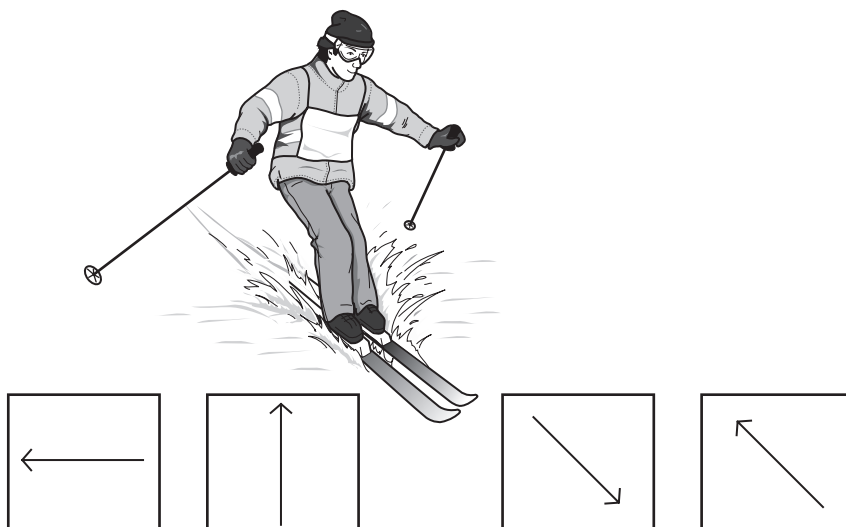

(b) (i) Circle the box to show the direction that friction acts on his skis.

[1]

(ii) As a result of the action of friction on the skis Benjamin will lose energy. Name **one** of the forms in which this energy is lost.

_____ energy [1]

Examiner Only	
Marks	Remark
○	○

- 5 The diagram shows a bird's eye view of a door being pushed by a force of 12 N.

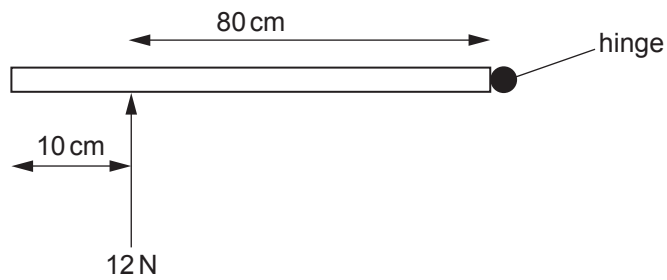

- (a) Calculate the moment exerted by the force about the hinge. Remember to include the unit with your answer.

You are advised to show your working out.

Moment = _____ [4]

- (b) State the direction of the moment about the hinge.

_____ [1]

Examiner Only	
Marks	Remark
○	○

6 A wine glass and a glass tumbler sit on a table.

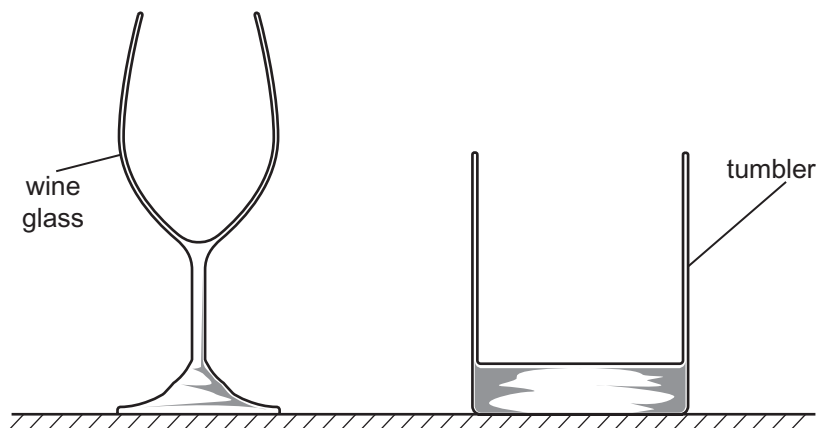

(i) Tick (✓) the correct statement below.

The wine glass is more stable than the tumbler.

The tumbler is more stable than the wine glass.

Both are equally stable.

[1]

(ii) Give two reasons for your answer.

1. _____

2. _____ [2]

Examiner Only	
Marks	Remark
<input type="text"/>	<input type="text"/>

- 7 An electric drill uses 800 J of electrical energy. 200 J of this energy is turned into heat and sound.

Calculate the efficiency of the electric drill.

You are advised to show your working out.

Efficiency = _____ [3]

Examiner Only	
Marks	Remark
○	○

8 A loudspeaker sits on a floor.

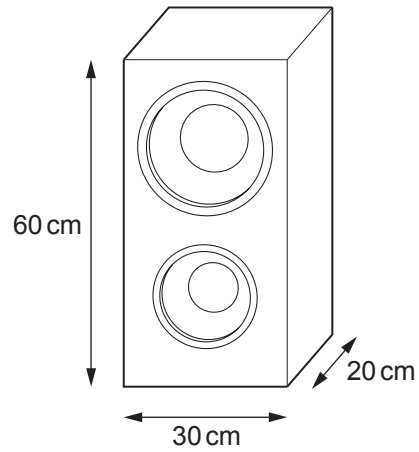

(i) Calculate the base area of the loudspeaker, in cm^2 .

Area = _____ cm^2 [1]

(ii) The weight of the loudspeaker is 200 N. Use your answer to part (i) to calculate the pressure it exerts on the floor, in N/cm^2 .

You are advised to show your working out.

Pressure = _____ N/cm^2 [3]

Examiner Only	
Marks	Remark
○	○

9 A satellite orbits the earth. Four directions are shown on the satellite.

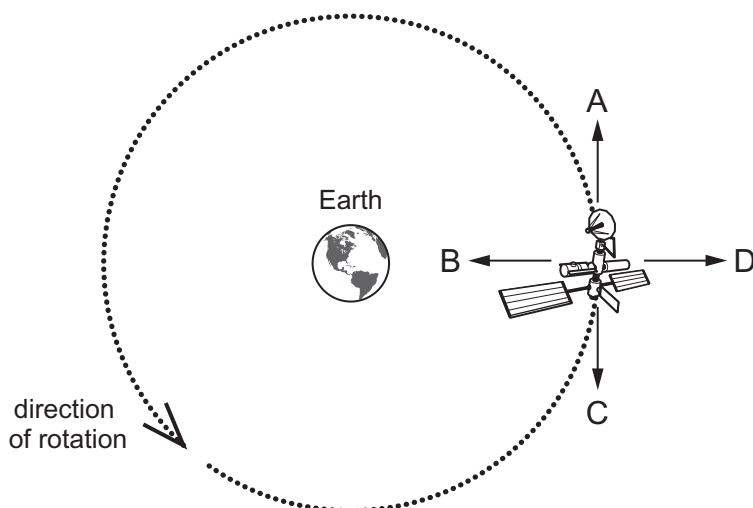

(a) (i) Which letter gives the direction of the force which keeps the satellite moving in a circular orbit?

Letter _____ [1]

(ii) Which letter gives the direction of the weight of the satellite?

Letter _____ [1]

(b) The mass of the satellite is 160 kg and it is moving at a steady speed of 2000 m/s. Calculate the satellite's momentum.

You are advised to show your working out.

Momentum = _____ kg m/s [3]

Examiner Only	
Marks	Remark
○	○

10 (a) State Hooke's Law.

[2]

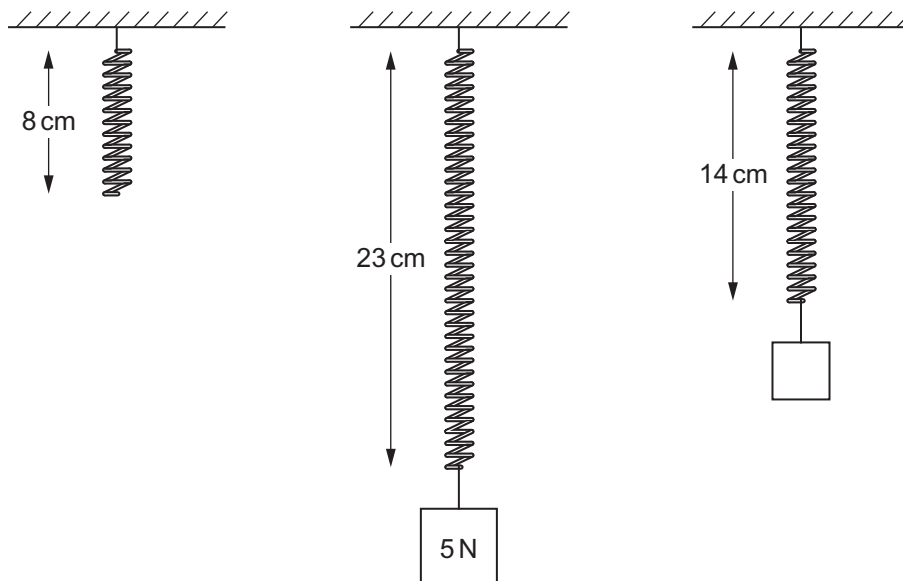

(b) A spring has a natural length of 8 cm. When loaded with a 5 N weight the total length of the spring is 23 cm. What weight would extend the spring so that its total length is 14 cm?

You are advised to show your working out.

Weight = _____ N [3]

Examiner Only	
Marks	Remark
○	○

11 Heat energy can be transferred from one point to another by different methods.

Listed below are a number of different statements. After each statement write down the name of the relevant method of heat transfer.



Involves vibrating atoms.

Does not require a medium.

Involves electrons colliding with atoms.

Involves movement of atoms from one place to another.

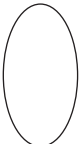
[4]

Examiner Only	
Marks	Remark
	

12 Flora walks to school and her distance–time graph is shown.

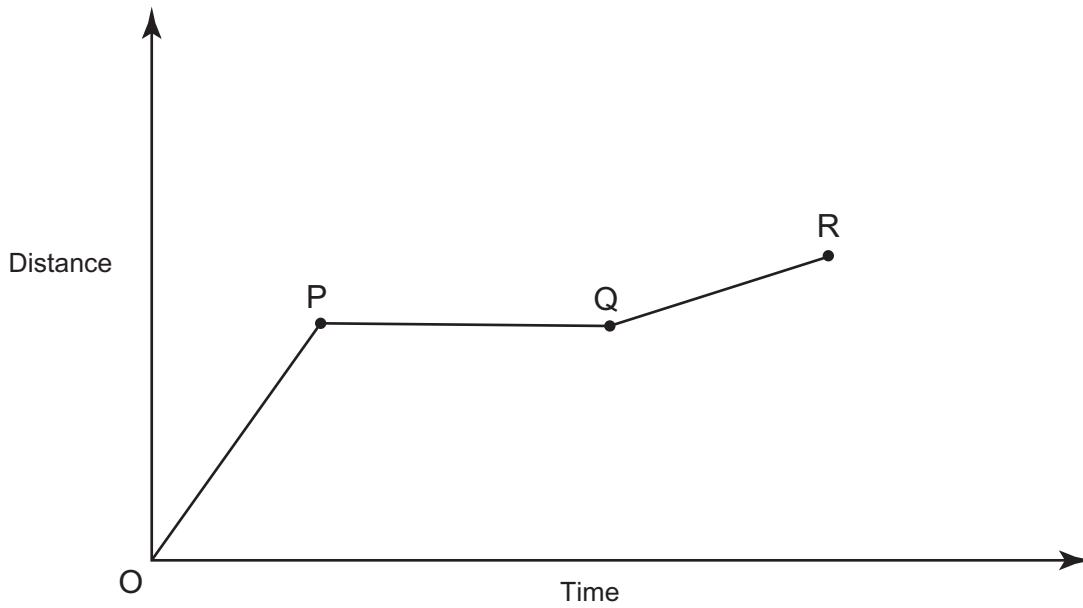

(a) During which part of the journey does Flora walk fastest?

_____ [1]

A number of statements are made below.

(b) Tick (✓) **two** correct statements which refer to Flora's walk.

Flora stops walking during PQ.

The distance to Flora's school is given by the area under the graph.

Flora's speed is increasing during OP.

Flora's speed during QR could be found by calculating the gradient of QR.

Flora walks slower during OP than during QR.

[2]

(c) Distance and displacement are both measured in metres. What is the difference between distance and displacement?

_____ [1]

Examiner Only	
Marks	Remark
○	○

THIS IS THE END OF THE QUESTION PAPER

Permission to reproduce all copyright material has been applied for.
In some cases, efforts to contact copyright holders may have been unsuccessful and CCEA
will be happy to rectify any omissions of acknowledgement in future if notified.