

Surname		Other Names	
Centre Number		Candidate Number	
Candidate Signature			

General Certificate of Secondary Education
Winter 2005



SCIENCE: SINGLE AWARD A (MODULAR)
Energy and Electricity (Module 17)

346017

Thursday 24 November 2005 Morning Session

In addition to this paper you will require:

- a black ball-point pen;
- an answer sheet.

You may use a calculator.

Time allowed: 30 minutes

Instructions

- Fill in the boxes at the top of this page.
- Check that your name, candidate number and centre number are printed on the separate answer sheet.
- Check that the separate answer sheet has the title “Energy and Electricity” printed on it.
- Attempt **one Tier only**, **either** the Foundation Tier **or** the Higher Tier.
- Make sure that you use the correct side of the separate answer sheet; the Foundation Tier is printed on one side and the Higher Tier on the other.
- Answer **all** the questions for the Tier you are attempting.
- Record your answers on the separate answer sheet only. Rough work may be done on the question paper.

Instructions for recording answers

- Use a **black ball-point pen**.

- For each answer **completely fill in the circle** as shown:

1	2	3	4
<input type="radio"/>	<input checked="" type="radio"/>	<input type="radio"/>	<input type="radio"/>

- Do **not** extend beyond the circles.

- If you want to change your answer, **you must** cross out your original answer, as shown:

1	2	3	4
<input type="radio"/>	<input checked="" type="radio"/>	<input type="radio"/>	<input checked="" type="radio"/>

- If you change your mind about an answer you have crossed out and now want to choose it, draw a ring around the cross as shown:

1	2	3	4
<input type="radio"/>	<input checked="" type="radio"/>	<input type="radio"/>	<input checked="" type="radio"/>

Information

- The maximum mark for this paper is 36.

Advice

- Do **not** choose more responses than you are asked to. You will lose marks if you do.
- Make sure that you hand in both your answer sheet and this question paper at the end of the test.
- If you start to answer on the wrong side of the answer sheet by mistake, make sure that you cross out **completely** the work that is not to be marked.

You must do **one Tier** only, **either** the Foundation Tier **or** the Higher Tier.
The Higher Tier starts on page 16 of this booklet.

FOUNDATION TIER

SECTION A

Questions **ONE** to **FIVE**.

In these questions match the words in the list with the numbers.

Use **each** answer only **once**.

Mark your choices on the answer sheet.

QUESTION ONE

Match words from the list with the labels **1–4** on the circuit diagram.

battery

lamp

resistor

switch

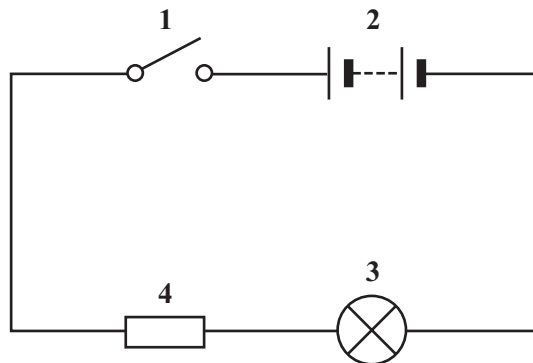

QUESTION TWO

Energy transfers take place in a television set.

Match words from the list with the numbers 1–4 in the sentences.

electrical

heat

light

sound

The screen is designed to
produce 1 energy.

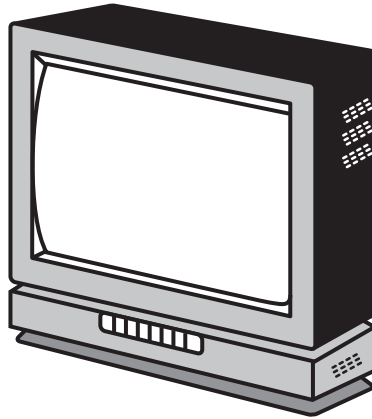

Ventilation slots help the set
to lose 2 energy.

The loudspeaker changes 3
energy into 4 energy.

TURN OVER FOR THE NEXT QUESTION

Turn over ►

QUESTION THREE

The diagram shows the inside of a 3-pin plug.

Match words from the list with the labels 1–4 on the diagram.

brass

fuse

live

neutral

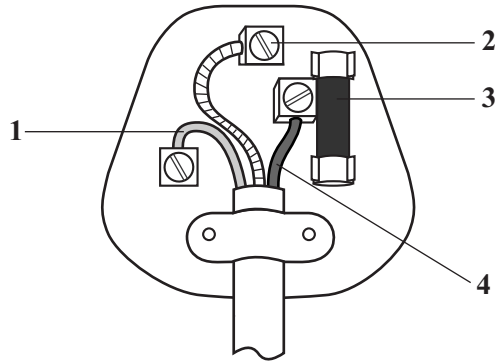

QUESTION FOUR

Transformers are used to change the voltage of an a.c. supply.

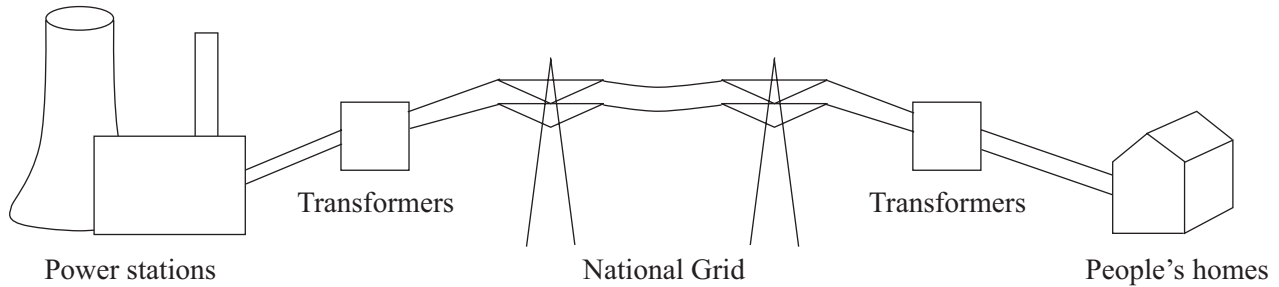

Match words from the list with the numbers 1–4 in the boxes.

people's homes

power stations

the voltage is decreased

the voltage is increased

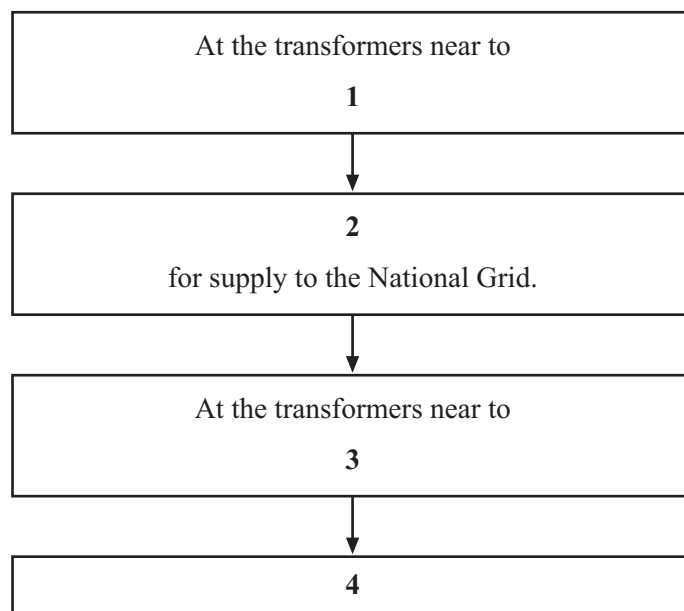

Turn over ►

QUESTION FIVE

The drawing shows a hydroelectric power station. Water falls from the higher lake to the lower lake. It passes through turbines near the bottom of the dam.

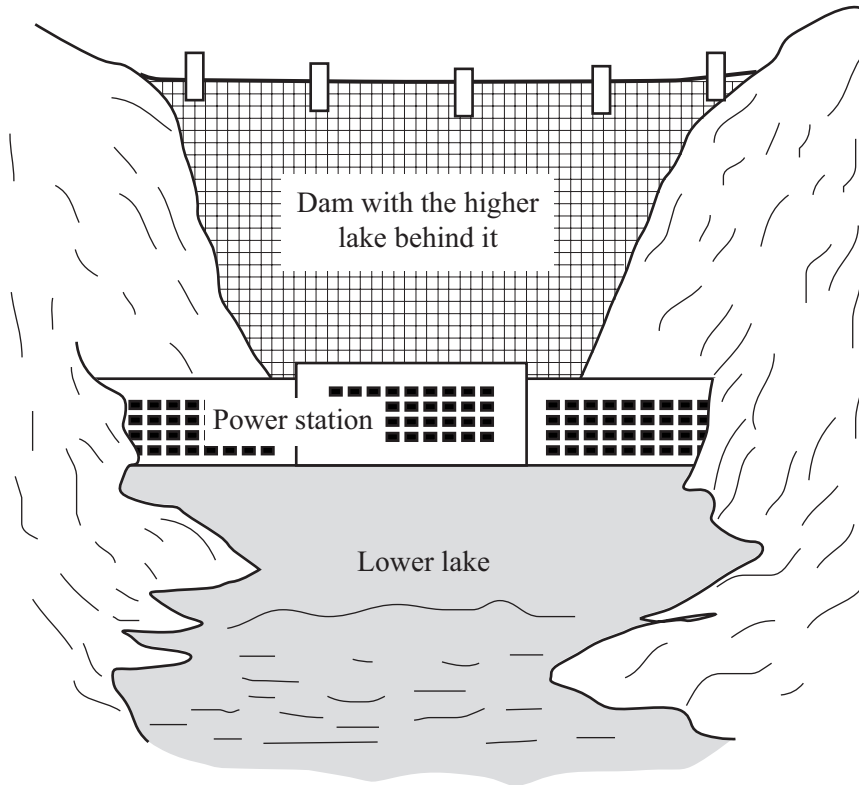

Match words from the list with the numbers 1–4 in the sentences to explain how the power station works.

electrical

gravitational potential

heat

kinetic

The water in the higher lake has **1** energy.

When the water falls, energy is transferred as **2** energy.

This energy turns the turbines, driving generators which produce **3** energy.

The water in the lower lake is slightly warmer than the water in the higher lake.

This is because some of the energy is transferred as **4** energy.

NO QUESTIONS APPEAR ON THIS PAGE

TURN OVER FOR THE NEXT QUESTION

Turn over ►

SECTION BQuestions **SIX** and **SEVEN**.In these questions choose the best **two** answers.Do **not** choose more than two.Mark your choices on the answer sheet.

QUESTION SIX

This canal boat is using renewable sources of energy to recharge its batteries.

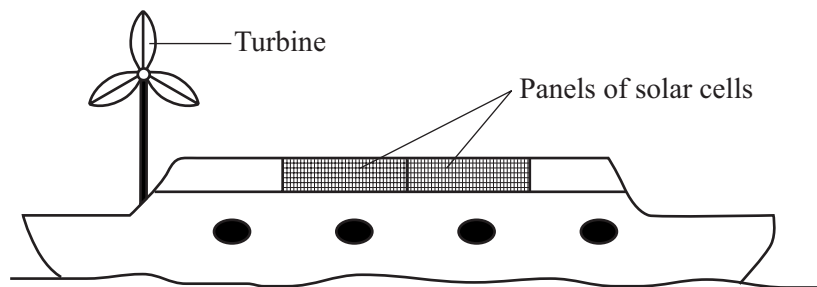
Which **two** energy sources are being used by the canal boat?**the Sun****tides****water behind a dam****waves on the water****wind**

QUESTION SEVEN

Which **two** arrangements of meters could be used to measure the resistance of the resistor?

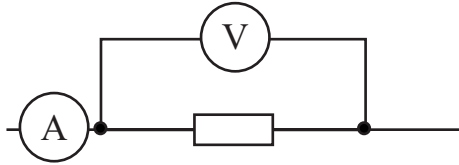

Arrangement J

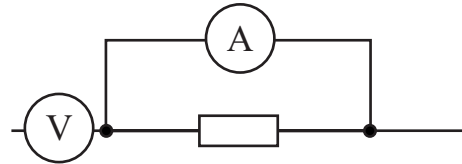

Arrangement K

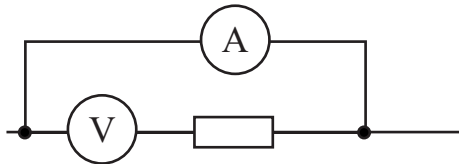

Arrangement L

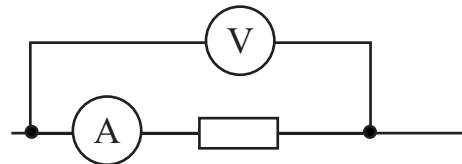

Arrangement M

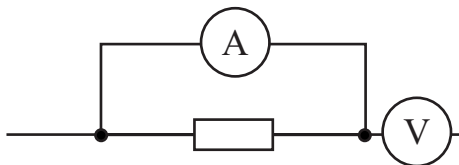

Arrangement N

TURN OVER FOR THE NEXT QUESTION

Turn over ►

SECTION CQuestions **EIGHT** to **TEN**.

Each of these questions has four parts.

In each part choose only **one** answer.

Mark your choices on the answer sheet.

QUESTION EIGHT

The following circuit was set up.

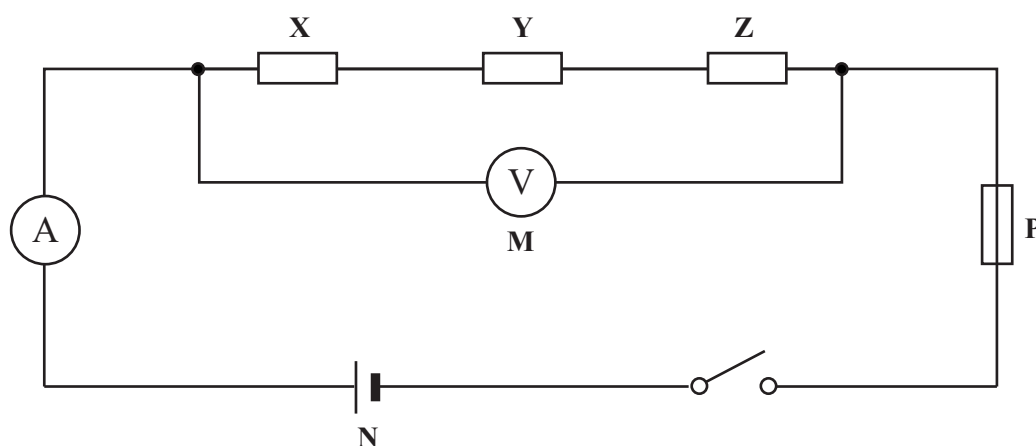
**8.1** Which row of the table, **A**, **B**, **C** or **D**, gives the names of components **N**, **P** and **X**?

	N	P	X
A	cell	fuse	resistor
B	cell	resistor	thermistor
C	switch	thermistor	resistor
D	thermistor	resistor	switch

8.2 Which one of the following is correct?

- A** X, Y and Z are connected in parallel with each other and in parallel with M
- B** X, Y and Z are connected in parallel with each other and in series with M
- C** X, Y and Z are connected in series with each other and in parallel with M
- D** X, Y and Z are connected in series with each other and in series with M

8.3 Which equation relates potential difference, current and resistance?

- A** potential difference = current + resistance
- B** potential difference = current – resistance
- C** potential difference = current × resistance
- D** potential difference = current ÷ resistance

8.4 A 3 ohm resistor is connected in series with a 4 ohm resistor.

Their total resistance is

- A** 1.0 Ω
- B** 1.3 Ω
- C** 7.0 Ω
- D** 12.0 Ω

TURN OVER FOR THE NEXT QUESTION

Turn over ►

QUESTION NINE

You may find the following formula useful when answering this question.

$$\begin{array}{l} \text{energy transferred} \\ \text{(kilowatt-hour, kWh)} \end{array} = \begin{array}{l} \text{power} \\ \text{(kilowatt, kW)} \end{array} \times \begin{array}{l} \text{time} \\ \text{(hour, h)} \end{array}$$

The diagram shows an electricity meter reading on two different dates.

7	2	3	4
---	---	---	---

1st April 2005

8	4	6	8
---	---	---	---

1st July 2005

- 9.1** How many Units were used between 1st April and 1st July 2005?
- A 34
 - B 234
 - C 1000
 - D 1234
- 9.2** What else would you need to know to work out the cost of the electricity used between these dates?
- A The cost of one Unit
 - B The maximum current in amps
 - C The time between the readings
 - D The voltage of the supply

- 9.3** What is measured by the Units shown on the meter?
- A** The amount of energy used
 - B** The number of electrons that have passed through
 - C** The power of the appliances used
 - D** The time for which the supply has been used
- 9.4** Which of the following would use one Unit of electricity?
- A** A 1 kilowatt heater switched on for 1 hour
 - B** A 1 kilowatt heater switched on for 1 second
 - C** A 100 watt light bulb switched on for 10 minutes
 - D** A 1 watt indicator lamp switched on for 1 second

TURN OVER FOR THE NEXT QUESTION

Turn over ►

QUESTION TEN

The drawing shows an array of solar cells.

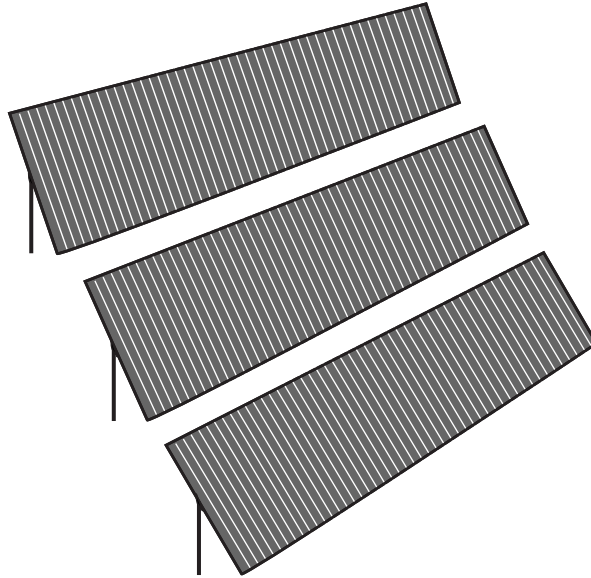

When it is sunny, the array produces between 1 kW and 4 kW of electricity. It can provide 7500 kWh per year.

10.1 The words *between 1 kW and 4 kW* describe the

- A efficiency.
- B energy output.
- C number of Units used.
- D power output.

10.2 The value of *7500 kWh* gives the

- A electrical energy output.
- B electrical power input.
- C electrical power output.
- D solar energy input.

10.3 Solar cells transfer

- A electrical energy to light energy.
- B electrical energy to thermal energy.
- C light energy to electrical energy.
- D thermal energy to light energy.

10.4 A disadvantage of using solar cells is that

- A they are expensive to make.
- B they can be used only in remote locations.
- C they can be used only where very small amounts of electricity are needed.
- D they produce a lot of noise.

END OF TEST

You must do **one Tier** only, **either** the Foundation Tier **or** the Higher Tier.
The Foundation Tier is earlier in this booklet.

HIGHER TIER

SECTION A

Questions **ONE** and **TWO**.

In these questions match the words in the list with the numbers.

Use **each** answer only **once**.

Mark your choices on the answer sheet.

QUESTION ONE

The drawing shows a hydroelectric power station. Water falls from the higher lake to the lower lake. It passes through turbines near the bottom of the dam.

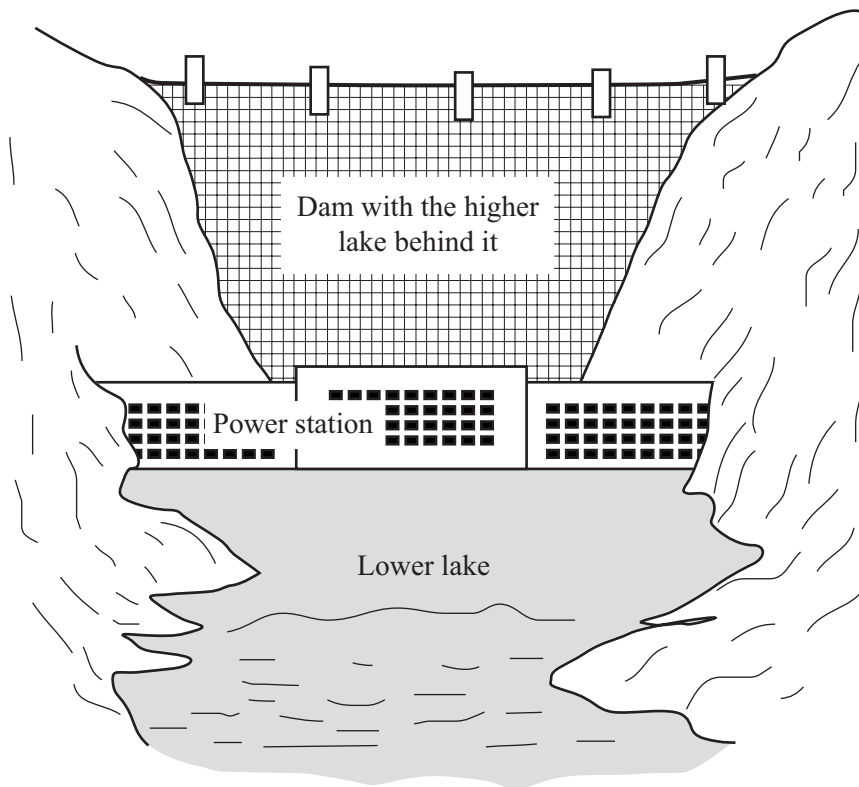

Match words from the list with the numbers **1–4** in the sentences to explain how the power station works.

electrical

gravitational potential

heat

kinetic

The water in the higher lake has **1** energy.

When the water falls, energy is transferred as **2** energy.

This energy turns the turbines, driving generators which produce **3** energy.

The water in the lower lake is slightly warmer than the water in the higher lake.

This is because some of the energy is transferred as **4** energy.

TURN OVER FOR THE NEXT QUESTION

Turn over ►

QUESTION TWO

The time taken to start up different types of power station varies. The graphs show how the power produced changes after the power station has been switched on. All the graphs have the same scales.

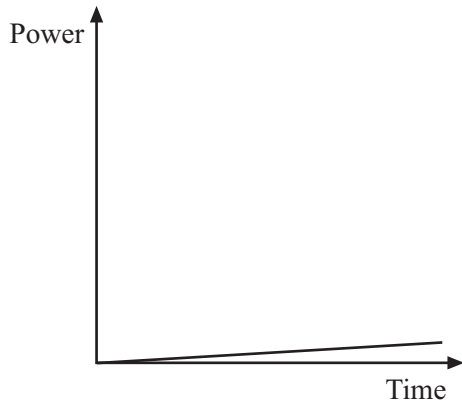

Graph 1

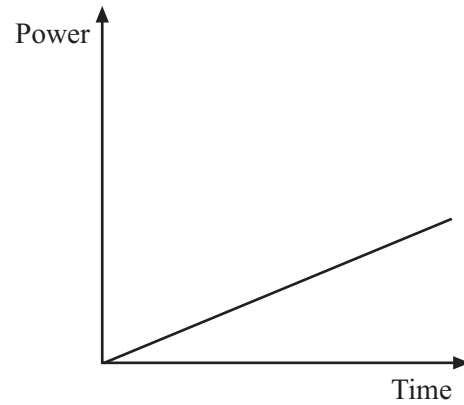

Graph 2

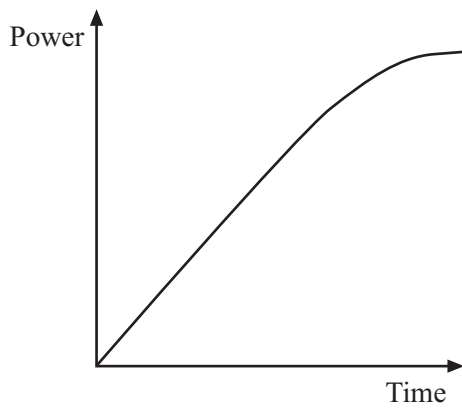

Graph 3

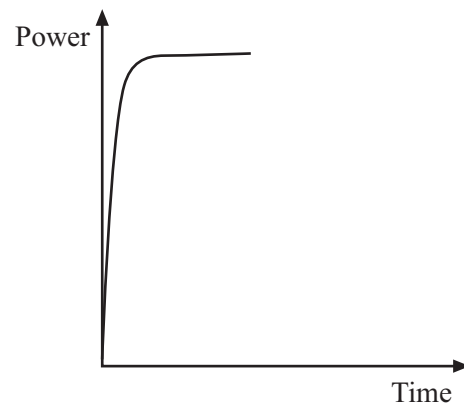

Graph 4

Match words from the list with the graphs 1–4.

coal-fired power station

hydroelectric power station

nuclear power station

oil-fired power station

SECTION BQuestions **THREE** and **FOUR**.In these questions choose the best **two** answers.Do **not** choose more than two.

Mark your choices on the answer sheet.

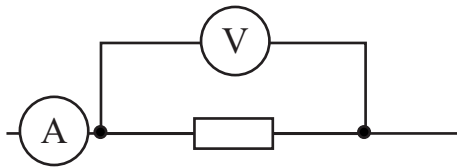
QUESTION THREEWhich **two** arrangements of meters could be used to measure the resistance of the resistor?

Arrangement J

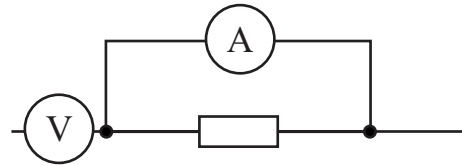

Arrangement K

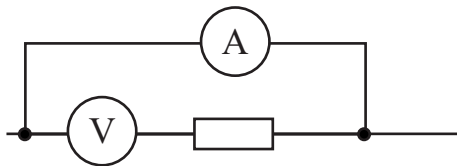

Arrangement L

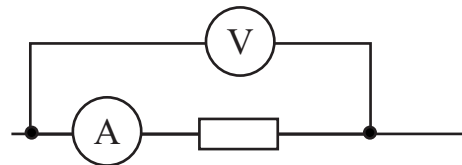

Arrangement M

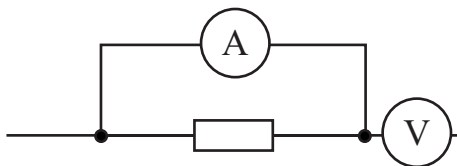

Arrangement N

Turn over ►

QUESTION FOUR

The current through two different resistors, **X** and **Y**, was measured as the potential difference across them was changed. The results are shown on the graph.

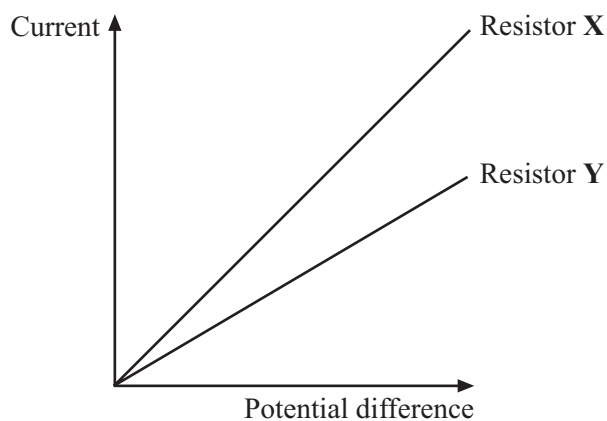

Which **two** of the statements **J**, **K**, **L**, **M** and **N** are correct?

- J** for a given potential difference, a larger current flows through resistor Y than through resistor X
- K** resistor Y has a greater resistance than resistor X
- L** the resistance of both resistors decreases with potential difference
- M** the resistance of both resistors increases with potential difference
- N** the temperature of both resistors remains constant

NO QUESTIONS APPEAR ON THIS PAGE

TURN OVER FOR THE NEXT QUESTION

Turn over ►

SECTION C

Questions **FIVE** to **TEN**.

Each of these questions has four parts.

In each part choose only **one** answer.

Mark your choices on the answer sheet.

QUESTION FIVE

The following circuit was set up.

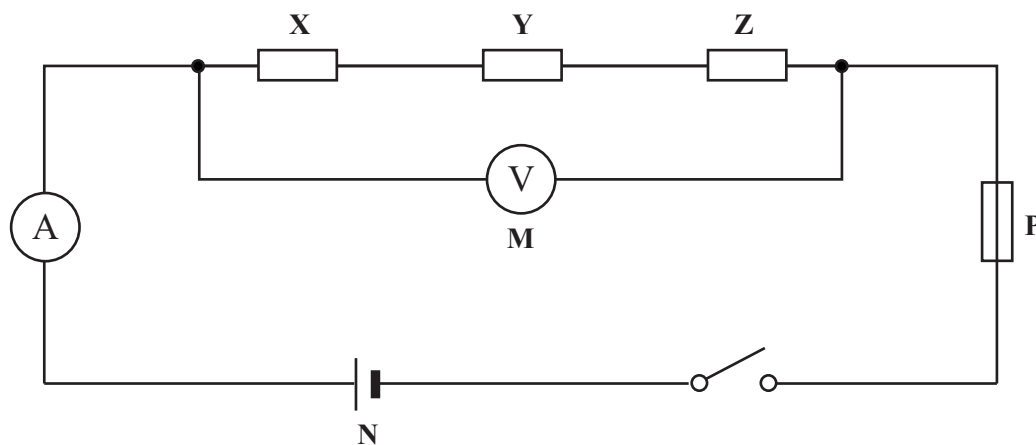

5.1 Which row of the table, **A**, **B**, **C** or **D**, gives the names of components **N**, **P** and **X**?

	N	P	X
A	cell	fuse	resistor
B	cell	resistor	thermistor
C	switch	thermistor	resistor
D	thermistor	resistor	switch

5.2 Which one of the following is correct?

- A** X, Y and Z are connected in parallel with each other and in parallel with M
- B** X, Y and Z are connected in parallel with each other and in series with M
- C** X, Y and Z are connected in series with each other and in parallel with M
- D** X, Y and Z are connected in series with each other and in series with M

5.3 Which equation relates potential difference, current and resistance?

- A** potential difference = current + resistance
- B** potential difference = current – resistance
- C** potential difference = current × resistance
- D** potential difference = current ÷ resistance

5.4 A 3 ohm resistor is connected in series with a 4 ohm resistor.

Their total resistance is

- A** 1.0 Ω
- B** 1.3 Ω
- C** 7.0 Ω
- D** 12.0 Ω

TURN OVER FOR THE NEXT QUESTION

Turn over ►

QUESTION SIX

You may find the following formula useful when answering this question.

$$\begin{array}{l} \text{energy transferred} \\ \text{(kilowatt-hour, kWh)} \end{array} = \begin{array}{l} \text{power} \\ \text{(kilowatt, kW)} \end{array} \times \begin{array}{l} \text{time} \\ \text{(hour, h)} \end{array}$$

The diagram shows an electricity meter reading on two different dates.

7	2	3	4
---	---	---	---

1st April 2005

8	4	6	8
---	---	---	---

1st July 2005

- 6.1** How many Units were used between 1st April and 1st July 2005?
- A 34
B 234
C 1000
D 1234
- 6.2** What else would you need to know to work out the cost of the electricity used between these dates?
- A The cost of one Unit
B The maximum current in amps
C The time between the readings
D The voltage of the supply

- 6.3** What is measured by the Units shown on the meter?
- A** The amount of energy used
 - B** The number of electrons that have passed through
 - C** The power of the appliances used
 - D** The time for which the supply has been used
- 6.4** Which of the following would use one Unit of electricity?
- A** A 1 kilowatt heater switched on for 1 hour
 - B** A 1 kilowatt heater switched on for 1 second
 - C** A 100 watt light bulb switched on for 10 minutes
 - D** A 1 watt indicator lamp switched on for 1 second

TURN OVER FOR THE NEXT QUESTION

Turn over ►

QUESTION SEVEN

The drawing shows an array of solar cells.

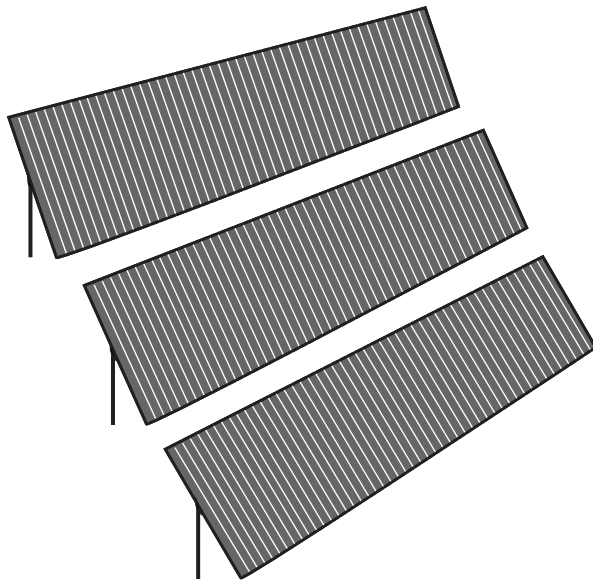

When it is sunny, the array produces between 1 kW and 4 kW of electricity. It can provide 7500 kWh per year.

7.1 The words *between 1 kW and 4 kW* describe the

- A efficiency.
- B energy output.
- C number of Units used.
- D power output.

7.2 The value of *7500 kWh* gives the

- A electrical energy output.
- B electrical power input.
- C electrical power output.
- D solar energy input.

7.3 Solar cells transfer

- A** electrical energy to light energy.
- B** electrical energy to thermal energy.
- C** light energy to electrical energy.
- D** thermal energy to light energy.

7.4 A disadvantage of using solar cells is that

- A** they are expensive to make.
- B** they can be used only in remote locations.
- C** they can be used only where very small amounts of electricity are needed.
- D** they produce a lot of noise.

TURN OVER FOR THE NEXT QUESTION

Turn over ►

QUESTION EIGHT

Some homes have hot water tanks in which an electric heater is used to heat the water.

Some heat (thermal energy) is lost through the metal wall to the surroundings.

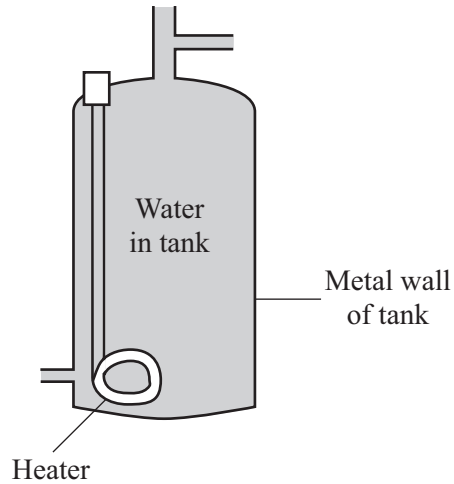

- 8.1** The energy spreads through the water by
- A** heat rising.
 - B** heated water contracting and falling.
 - C** heated water expanding and rising.
 - D** the movement of free electrons.
- 8.2** The energy is transferred through the metal wall of the tank by
- A** heated metal expanding and rising.
 - B** infra red waves passing through the metal.
 - C** the atoms gaining energy and moving faster through the metal.
 - D** the movement of free electrons.

8.3 The metal wall of the tank transfers energy to the surroundings by

- A heated air contracting and falling.
- B infra red waves passing through the air.
- C metal atoms gaining energy and escaping into the air.
- D the movement of free electrons.

8.4 The air in contact with the metal walls

- A contracts, and falls due to decreased density.
- B contracts, and falls due to increased density.
- C expands, and rises due to decreased density.
- D expands, and rises due to increased density.

TURN OVER FOR THE NEXT QUESTION

Turn over ►

QUESTION NINE

The diagram shows a tidal barrage system used to generate electricity. Before the barrage was built, parts of the mud-flats on the estuary were repeatedly covered with sea water as the tide came in and went out again.

Wading birds feed on the mud-flats by eating organisms that live in the mud.

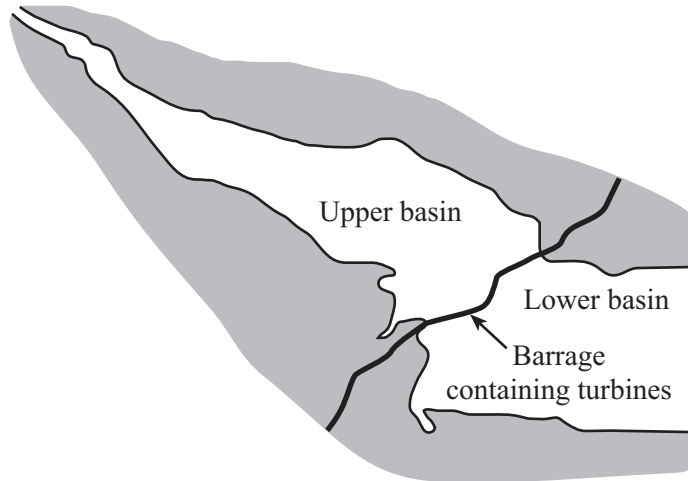

Section through barrage

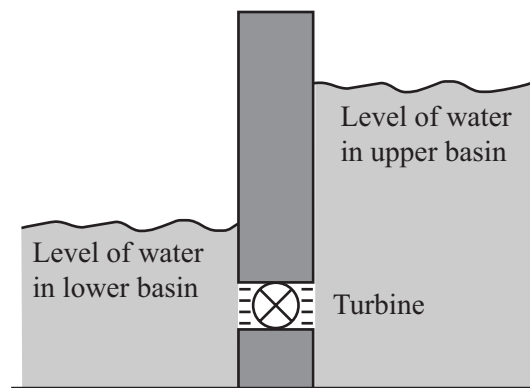

9.1 A student writes:

'In a tidal barrage system energy is wasted as

- heat
- light
- sound.'

How many of these three points are correct?

- A** None of them
- B** Only one of them
- C** Only two of them
- D** All of them

- 9.2** Which is the useful energy transfer as water flows from the upper basin through the turbine?
- A Electrical energy to gravitational potential energy
 - B Electrical energy to kinetic energy
 - C Gravitational potential energy to kinetic energy
 - D Kinetic energy to gravitational potential energy
- 9.3** Compared to a coal-fired power station with a similar generating capacity, a tidal barrage usually
- A costs more to build.
 - B has a more concentrated energy supply.
 - C has higher fuel costs.
 - D produces more pollution.
- 9.4** One disadvantage of this tidal barrage is that
- A it cannot be used in summer.
 - B it has low decommissioning costs.
 - C its output is constant.
 - D wading birds lose a food source.

TURN OVER FOR THE NEXT QUESTION

Turn over ►

QUESTION TEN

The diagram shows an a.c. generator connected to a light-emitting diode.

A light-emitting diode (LED) is a diode which gives out (emits) light when a current flows through it. The bigger the current through the LED, the brighter the light. The resistance of a light-emitting diode varies in the same way as that of an ordinary diode.

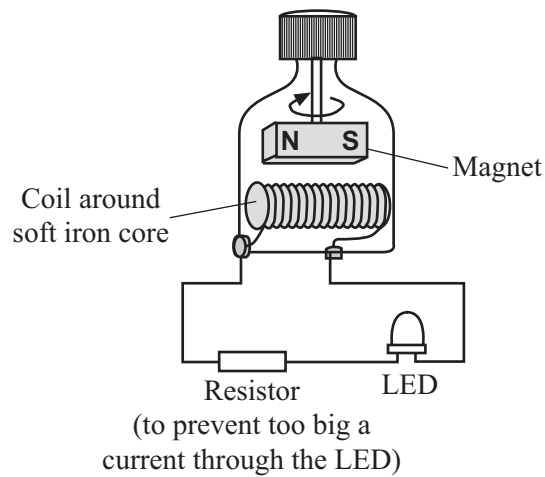

10.1 When the magnet turns, the generator produces a voltage across the ends of the coil.

Which of these graphs shows how the voltage across the ends of the coil varies with time?

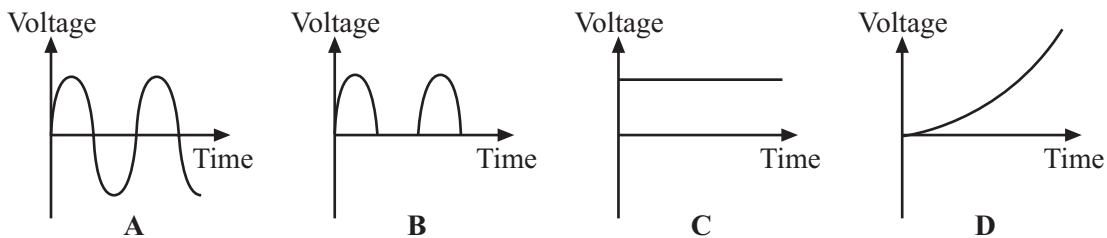

10.2 Which of these graphs shows how the current through the resistor and the LED varies with time?

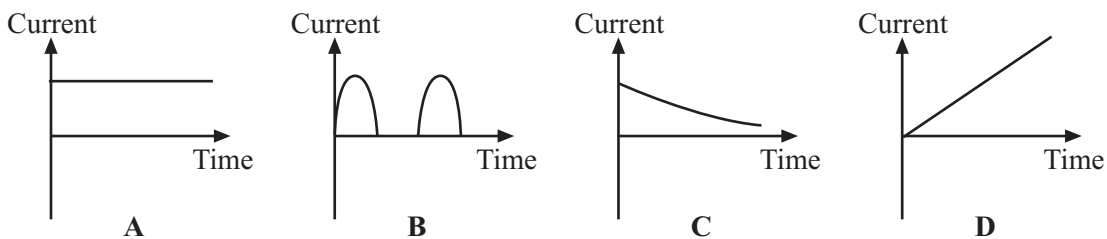

10.3 As the magnet spins, the LED

- A flashes once for every full turn of the magnet.
- B flashes once for every two full turns of the magnet.
- C flashes twice for every full turn of the magnet.
- D gives out a constant bright light.

10.4 The magnet is now turned twice as fast.

The LED now

- A flashes at the same rate as before, with a brighter light.
- B flashes twice as fast as before, with a brighter light.
- C flashes twice as fast as before, with the same brightness.
- D has a constant light which is brighter than before.

END OF TEST

THERE ARE NO QUESTIONS PRINTED ON THIS PAGE

THERE ARE NO QUESTIONS PRINTED ON THIS PAGE

THERE ARE NO QUESTIONS PRINTED ON THIS PAGE