

Surname		Other Names	
Centre Number		Candidate Number	
Candidate Signature			

General Certificate of Secondary Education
Spring 2005



SCIENCE: SINGLE AWARD A (MODULAR) 346017
Energy and Electricity (Module 17)

Wednesday 2 March 2005 Morning Session

In addition to this paper you will require:

- a black ball-point pen;
- an answer sheet.

You may use a calculator.

Time allowed: 30 minutes

Instructions

- Fill in the boxes at the top of this page.
- Check that your name, candidate number and centre number are printed on the separate answer sheet.
- Check that the separate answer sheet has the title “Energy and Electricity” printed on it.
- Attempt **one Tier only**, **either** the Foundation Tier **or** the Higher Tier.
- Make sure that you use the correct side of the separate answer sheet; the Foundation Tier is printed on one side and the Higher Tier on the other.
- Answer **all** the questions for the Tier you are attempting.
- Record your answers on the separate answer sheet only. Rough work may be done on the question paper.

Instructions for recording answers

- Use a **black ball-point pen**.

- For each answer **completely fill in the circle** as shown:

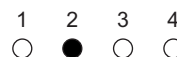

- Do **not** extend beyond the circles.

- If you want to change your answer, **you must** cross out your original answer, as shown:

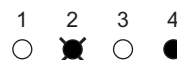

- If you change your mind about an answer you have crossed out and now want to choose it, draw a ring around the cross as shown:

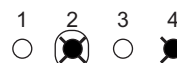

Information

- The maximum mark for this paper is 36.

Advice

- Do **not** choose more responses than you are asked to. You will lose marks if you do.
- Make sure that you hand in both your answer sheet and this question paper at the end of the test.
- If you start to answer on the wrong side of the answer sheet by mistake, make sure that you cross out **completely** the work that is not to be marked.

You must do **one Tier** only, **either** the Foundation Tier **or** the Higher Tier.
The Higher Tier starts on page 16 of this booklet.

FOUNDATION TIER

SECTION A

Questions **ONE** to **FIVE**.

In these questions match the words in the list with the numbers.

Use **each** answer only **once**.

Mark your choices on the answer sheet.

QUESTION ONE

The diagram shows places where heat is lost from a house.

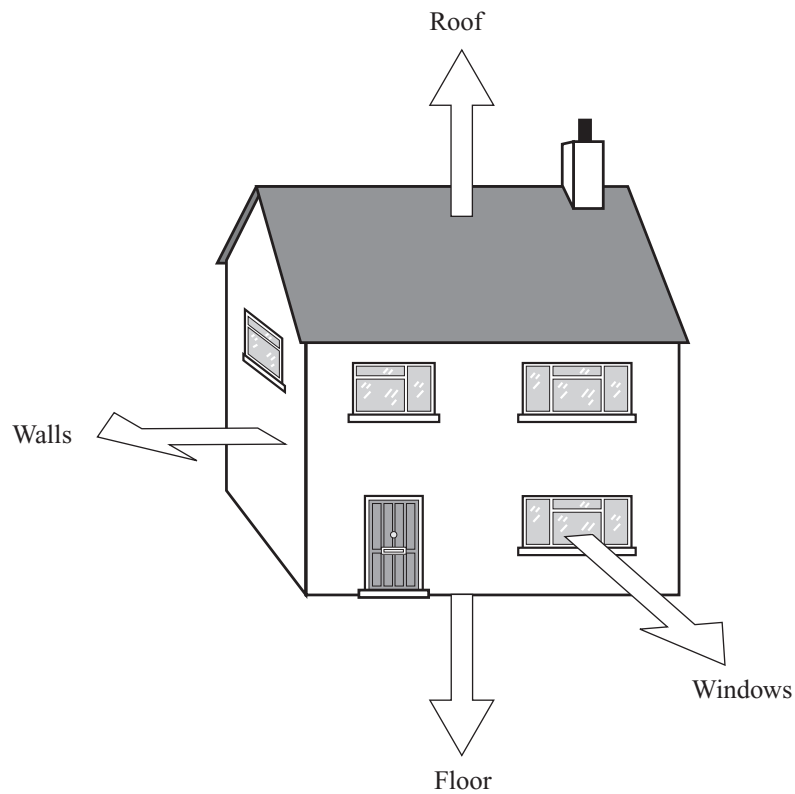

Match words from the list with the numbers 1–4 in the sentences.

conduction

convection currents

loss of warm air

radiation

Heat spreads from the inside of a brick wall to the outside by **1**

Heat spreads from downstairs to upstairs by **2**

When the doors or windows are open, heat is removed by **3**

The outside surfaces of a house lose heat by **4**

QUESTION TWO

The diagram shows a cable that is attached to an electric fire.
The cable will be connected to a plug when the fire is used.

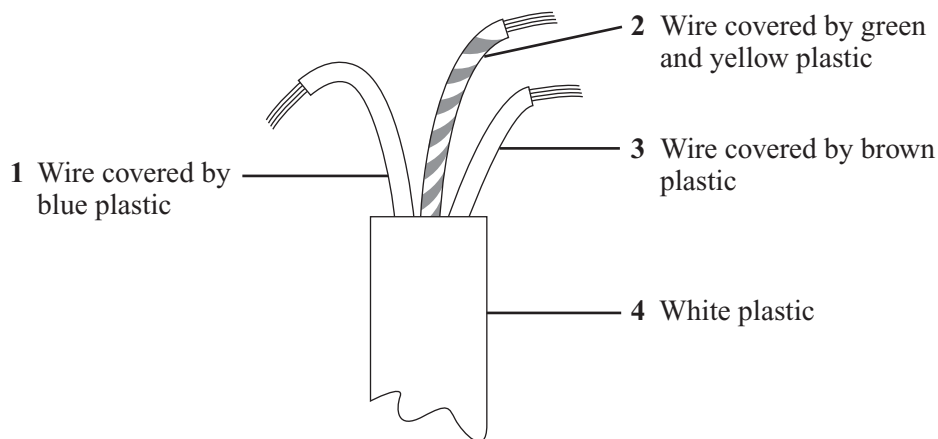

Match phrases E, F, G and H from the list with the labels 1–4 on the diagram.

E the cable grip is tightened on this

F connects the earth pin to the metal case of the fire

G is connected to the fuse

H is connected to the neutral terminal

Turn over ►

QUESTION THREE

This question is about four sources of energy which could be used in power stations.

Match words in the list with the numbers 1–4 in the sentences.

coal

gas

uranium

wood

Power stations using **1** produce radioactive waste.

Power stations using **2** produce the most carbon dioxide for each unit of electricity produced.

Power stations using **3** can be started up most quickly.

Power stations using **4** have the advantage of using a renewable energy resource.

QUESTION FOUR

This question is about one way of producing electricity.

Match words in the list with the numbers 1–4 in the sentences.

generator

steam

turbine

water

In some volcanic areas hot **1** and steam rise to the surface.

The **2** can be used to drive a **3**





Electricity is then produced by a **4**

QUESTION FIVE

The table shows symbols for some electrical components. Each component has a different function.

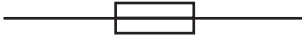
Match functions **P**, **Q**, **R** and **S** from the list with the numbers **1–4** in the table.

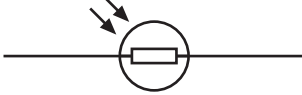
- P** allows current to flow in one direction only
- Q** changes resistance when the light intensity changes
- R** changes resistance when the temperature changes
- S** melts when the current is too large

Symbol	Function
	1
	2
	3
	4

TURN OVER FOR THE NEXT QUESTION

Turn over ►

SECTION BQuestions **SIX** and **SEVEN**.In these questions choose the best **two** answers.Do **not** choose more than two.Mark your choices on the answer sheet.

QUESTION SIX

This question is about electrical appliances which transfer energy.

Which **two** of the following statements **J**, **K**, **L**, **M** and **N** are correct?

- J** energy becomes less spread out after energy transfer
- K** energy is always wasted during energy transfer
- L** the more energy that is wasted during transfer, the more efficient the appliance is
- M** useful energy and wasted energy both end up making the surroundings warmer
- N** wasted energy can always be used for further energy transfers

QUESTION SEVEN

A student builds this circuit using two 2 V cells.

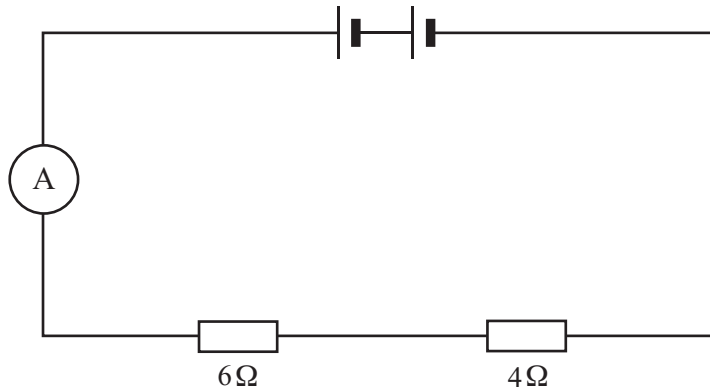

Which **two** statements are correct?

the potential difference (voltage) across the 4 Ω resistor is 0.8 V

the potential difference (voltage) across the 6 Ω resistor is 2.4 V

the potential difference (voltage) across the battery is 2 V

the total current in the circuit is 0.2 A

the total resistance is 10 Ω

TURN OVER FOR THE NEXT QUESTION

Turn over ►

SECTION CQuestions **EIGHT** to **TEN**.

Each of these questions has four parts.

In each part choose only **one** answer.

Mark your choices on the answer sheet.

QUESTION EIGHT

The diagram shows a circuit with several different components.

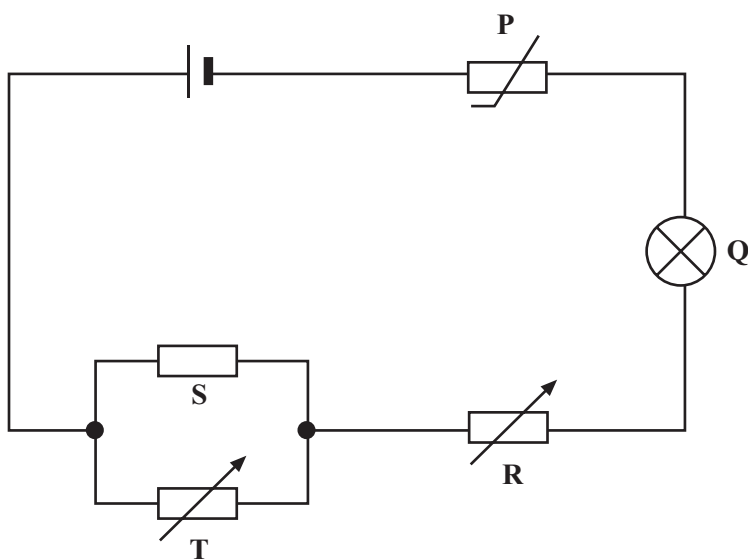
**8.1** The potential difference (voltage) across each component was measured.

Which components have the same potential difference across them?

- A P, Q and R only
- B P, Q, R, S and T
- C R and T only
- D S and T only

8.2 The graph shows how current changes with voltage across one of the components.

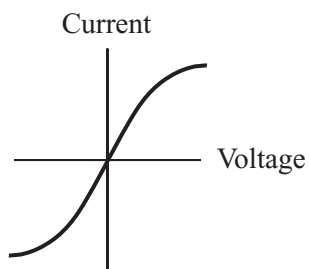

Which component would give this graph?

- A P
- B Q
- C R
- D S

8.3 Through which two components does the same size current flow?

- A P and Q
- B P and S
- C P and T
- D R and T

8.4 Which component has a resistance which increases when temperature increases?

- A P
- B Q
- C R
- D S

Turn over ►

QUESTION NINE

The diagram shows a group of wind generators which supply electricity to a small town.

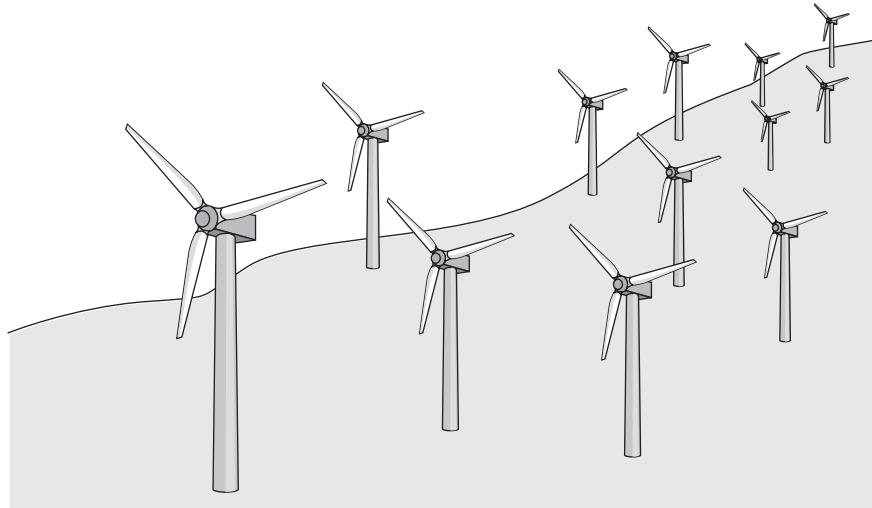

- 9.1** A group of wind generators is called a wind
- A** barrage.
 - B** dam.
 - C** farm.
 - D** turbine.
- 9.2** Which type of energy is transferred from the wind to generate electricity?
- A** Gravitational potential
 - B** Kinetic
 - C** Sound
 - D** Thermal
- 9.3** Where would you **not** expect to find a group of wind generators?
- A** In a town
 - B** Offshore – out at sea
 - C** On a coastal cliff
 - D** On the top of a hill

9.4 Which graph is most likely to show the output from a wind generator over one day?

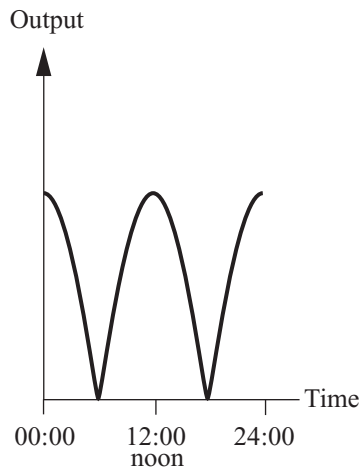
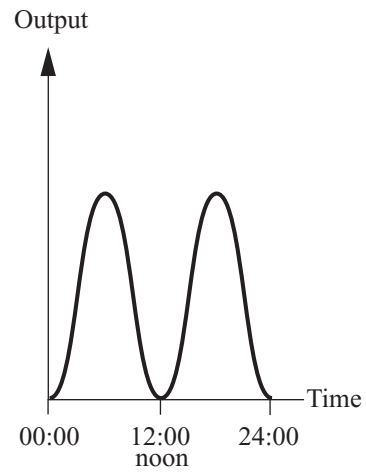
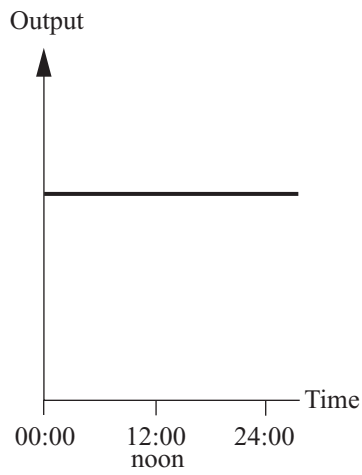
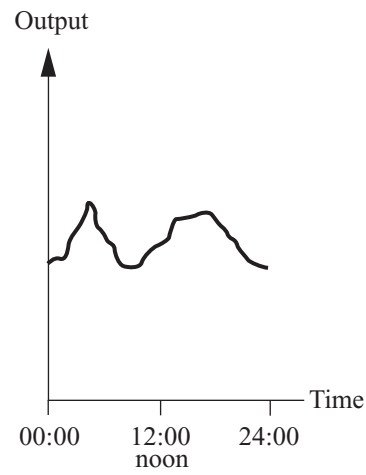
**A****B****C****D**

TURN OVER FOR THE NEXT QUESTION

Turn over ►

QUESTION TEN

A generator is used to produce electricity.

The diagram shows a simple generator.

An oscilloscope is used to investigate the potential difference (voltage) produced.

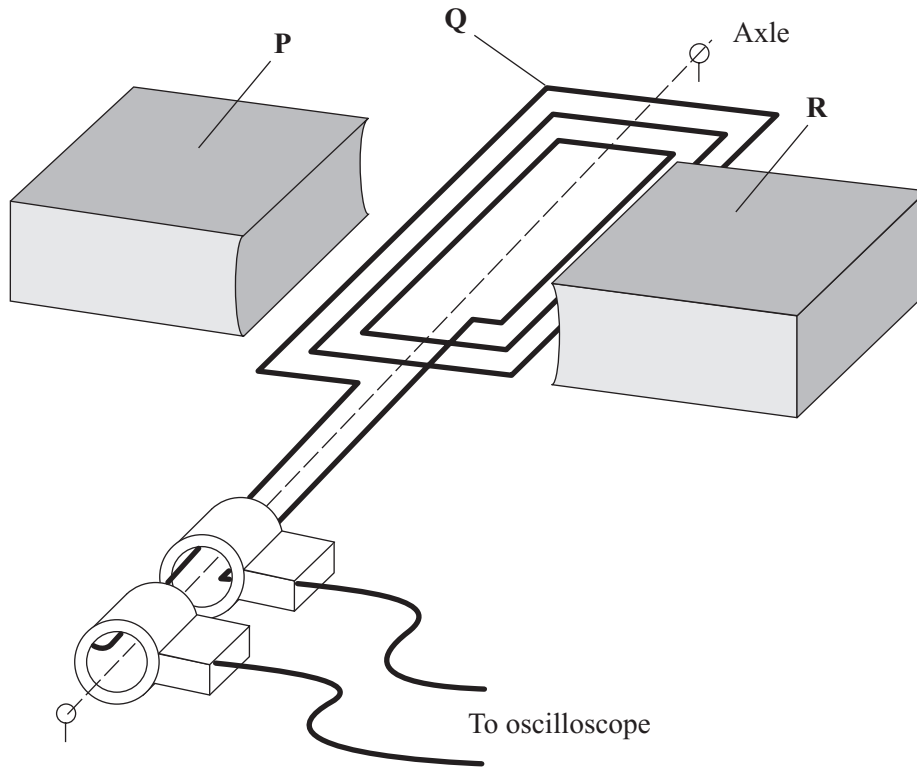

10.1 Which row of the table gives the correct labels on the diagram?

	P	Q	R
A	coil	N-pole	N-pole
B	N-pole	coil	S-pole
C	N-pole	coil	N-pole
D	S-pole	coil	S-pole

10.2 The induced voltage depends on the area of the coil and the number of turns on it.

Which combination would give the biggest voltage?

	Area of coil	Number of turns
A	large	large
B	small	large
C	large	small
D	small	small

10.3 The graph shows the oscilloscope display.

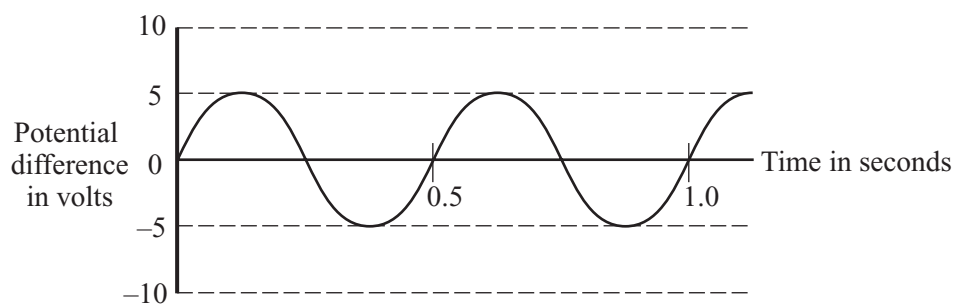

The a.c. voltage shown on this graph is

- A** 5 V and 0.5 Hz.
- B** 5 V and 2.0 Hz.
- C** 10 V and 0.5 Hz.
- D** 10 V and 2.0 Hz.

QUESTION TEN CONTINUES ON THE NEXT PAGE

Turn over ►

10.4 The coil is now rotated at twice the original speed. The oscilloscope settings are not changed.

What will the oscilloscope display look like now?

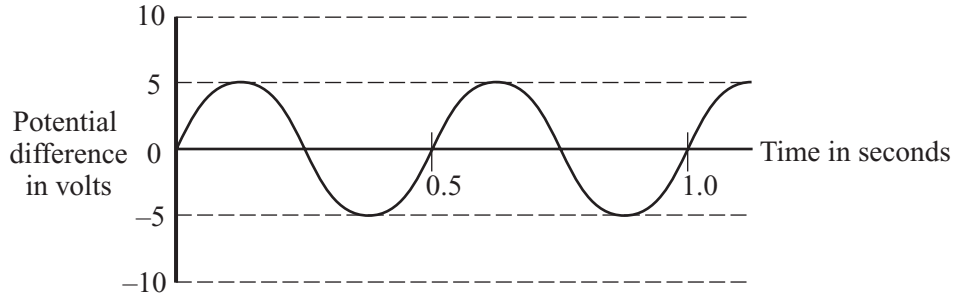

A

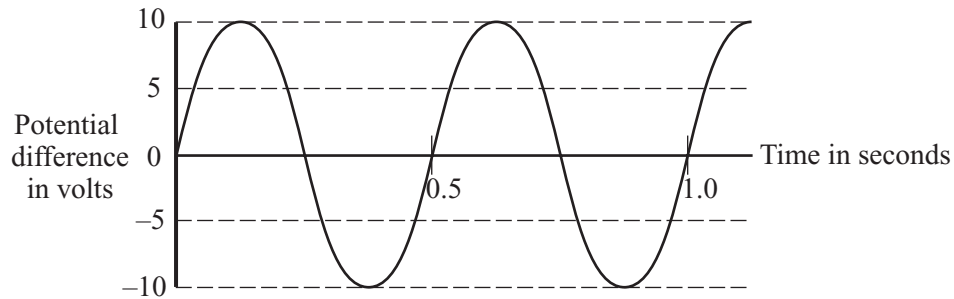

B

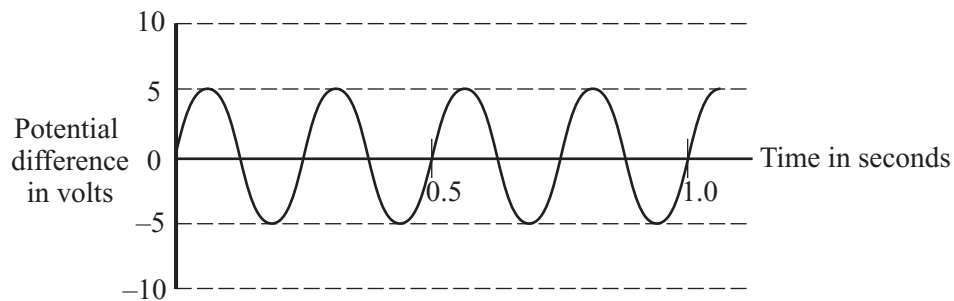

C

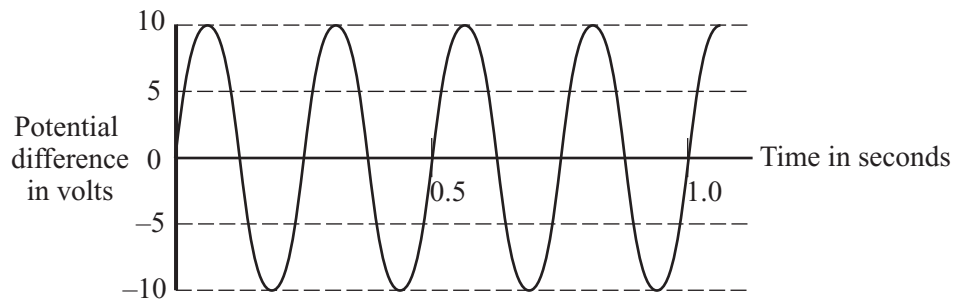

D

END OF TEST

THERE ARE NO QUESTIONS PRINTED ON THIS PAGE

You must do **one Tier** only, **either** the Foundation Tier **or** the Higher Tier.
The Foundation Tier is earlier in this booklet.

HIGHER TIER

SECTION A

Questions **ONE** and **TWO**.

In these questions match the words in the list with the numbers.

Use **each** answer only **once**.





Mark your choices on the answer sheet.

QUESTION ONE

The table shows symbols for some electrical components. Each component has a different function.

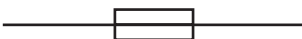
Match functions **P**, **Q**, **R** and **S** from the list with the numbers **1–4** in the table.

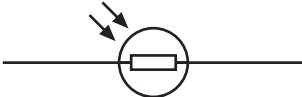
- P** allows current to flow in one direction only
- Q** changes resistance when the light intensity changes
- R** changes resistance when the temperature changes
- S** melts when the current is too large

Symbol	Function
	1
	2
	3
	4

QUESTION TWO

Thermal energy can be transferred in different ways.

Match words from the list with the numbers **1–4** in the sentences.

free electrons

ions

particles

waves

Convection currents in liquids and gases are the result of expansion caused by **1** moving faster in hotter regions.

Thermal radiation is energy transferred by **2**

The hotter a metal is, the greater the kinetic energy of the vibrating **3** in the metal structure.

Kinetic energy is transferred to cooler parts of a metal by **4** diffusing through it.

TURN OVER FOR THE NEXT QUESTION

Turn over ►

SECTION BQuestions **THREE** and **FOUR**.In these questions choose the best **two** answers.Do **not** choose more than two.

Mark your choices on the answer sheet.

QUESTION THREE

A student builds this circuit using two 2 V cells.

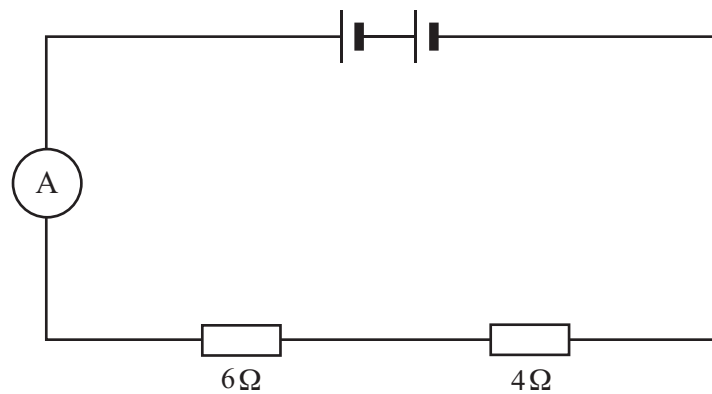
Which **two** statements are correct?**the potential difference (voltage) across the 4 Ω resistor is 0.8 V****the potential difference (voltage) across the 6 Ω resistor is 2.4 V****the potential difference (voltage) across the battery is 2 V****the total current in the circuit is 0.2 A****the total resistance is 10 Ω**

QUESTION FOUR

The diagram shows a circuit containing four identical lamps.
The potential difference (voltage) across the battery is 8 V.

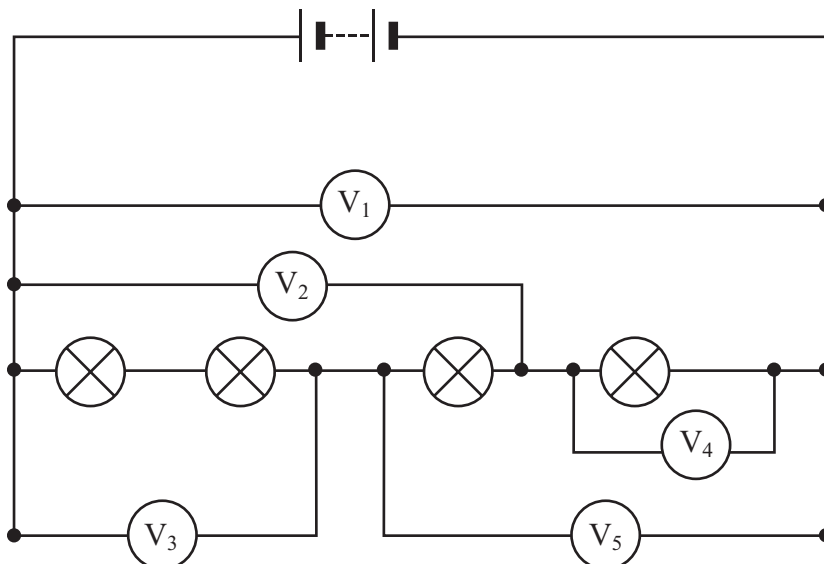

Which **two** of the voltmeter readings are correct?

V_1 has a reading of 1 V

V_2 has a reading of 6 V

V_3 has a reading of 4 V

V_4 has a reading of 6 V

V_5 has a reading of 3 V

TURN OVER FOR THE NEXT QUESTION

Turn over ►

SECTION CQuestions **FIVE** to **TEN**.

Each of these questions has four parts.

In each part choose only **one** answer.

Mark your choices on the answer sheet.

QUESTION FIVE

The diagram shows a circuit with several different components.

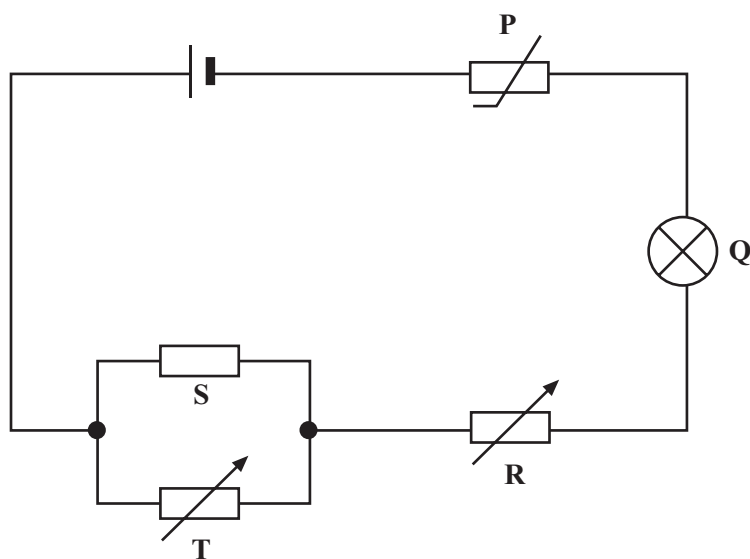

5.1 The potential difference (voltage) across each component was measured.

Which components have the same potential difference across them?

- A** P, Q and R only
- B** P, Q, R, S and T
- C** R and T only
- D** S and T only

5.2 The graph shows how current changes with voltage across one of the components.

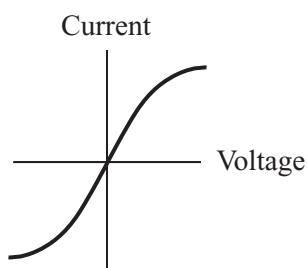

Which component would give this graph?

- A P
- B Q
- C R
- D S

5.3 Through which two components does the same size current flow?

- A P and Q
- B P and S
- C P and T
- D R and T

5.4 Which component has a resistance which increases when temperature increases?

- A P
- B Q
- C R
- D S

Turn over ►

QUESTION SIX

The diagram shows a group of wind generators which supply electricity to a small town.

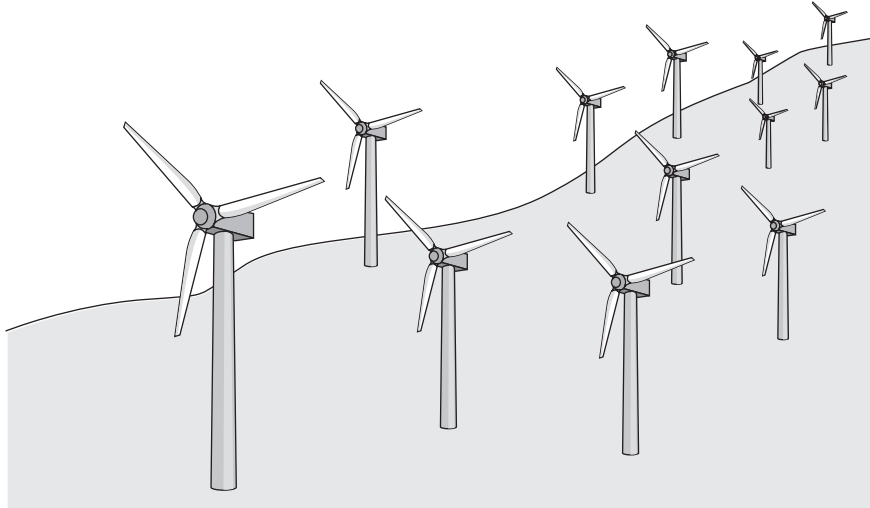

- 6.1** A group of wind generators is called a wind
- A** barrage.
 - B** dam.
 - C** farm.
 - D** turbine.
- 6.2** Which type of energy is transferred from the wind to generate electricity?
- A** Gravitational potential
 - B** Kinetic
 - C** Sound
 - D** Thermal
- 6.3** Where would you **not** expect to find a group of wind generators?
- A** In a town
 - B** Offshore – out at sea
 - C** On a coastal cliff
 - D** On the top of a hill

6.4 Which graph is most likely to show the output from a wind generator over one day?

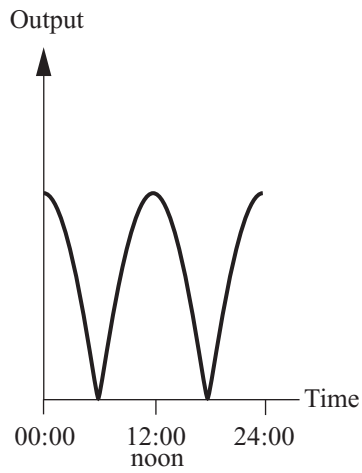
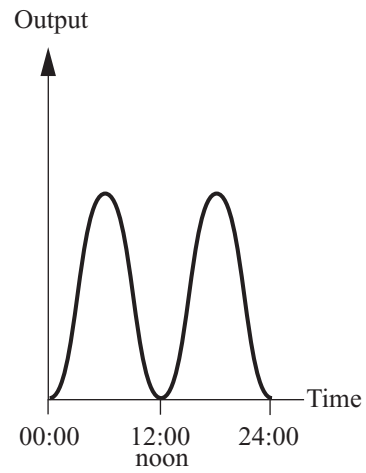
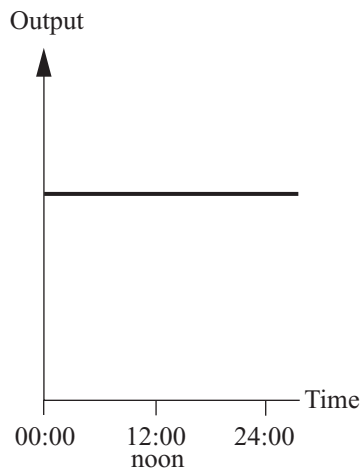
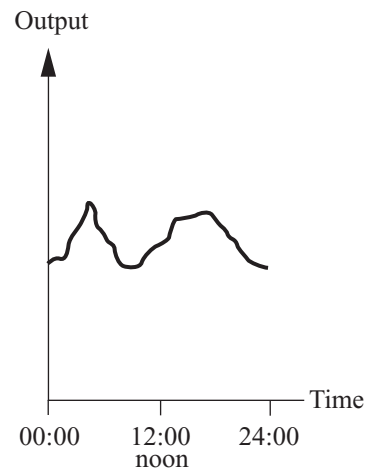
**A****B****C****D**

TURN OVER FOR THE NEXT QUESTION

Turn over ►

QUESTION SEVEN

A generator is used to produce electricity.

The diagram shows a simple generator.

An oscilloscope is used to investigate the potential difference (voltage) produced.

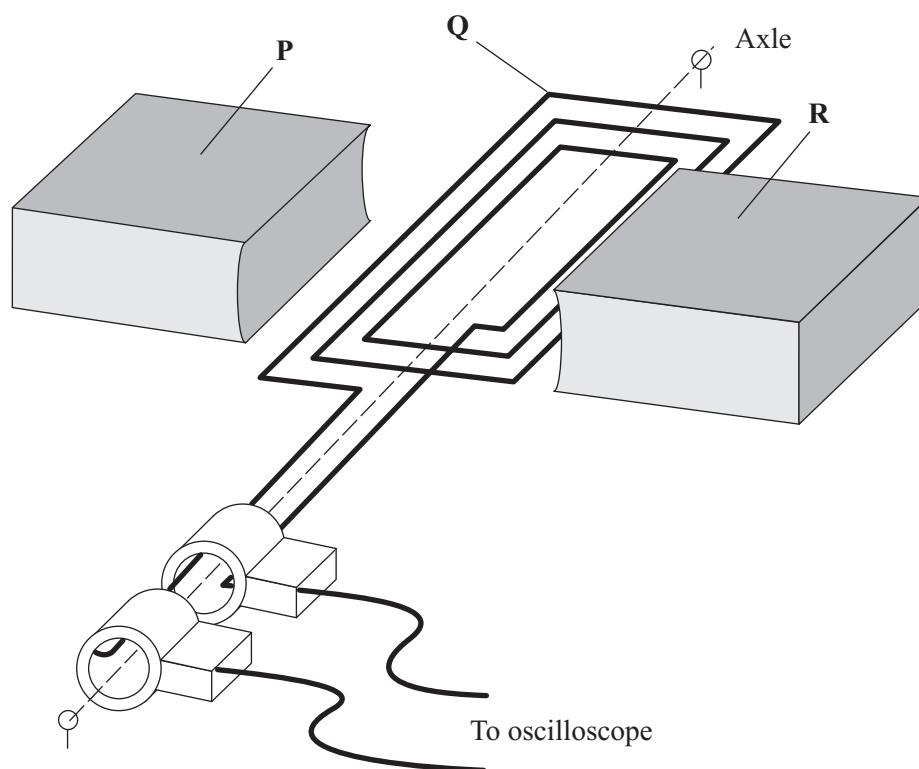

7.1 Which row of the table gives the correct labels on the diagram?

	P	Q	R
A	coil	N-pole	N-pole
B	N-pole	coil	S-pole
C	N-pole	coil	N-pole
D	S-pole	coil	S-pole

7.2 The induced voltage depends on the area of the coil and the number of turns on it.

Which combination would give the biggest voltage?

	Area of coil	Number of turns
A	large	large
B	small	large
C	large	small
D	small	small

7.3 The graph shows the oscilloscope display.

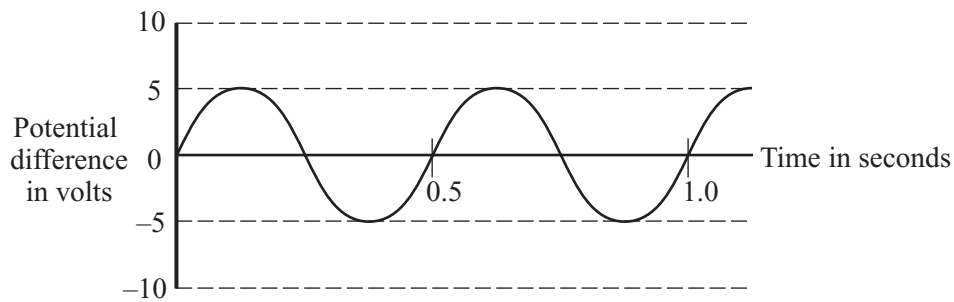

The a.c. voltage shown on this graph is

- A 5 V and 0.5 Hz.
- B 5 V and 2.0 Hz.
- C 10 V and 0.5 Hz.
- D 10 V and 2.0 Hz.

QUESTION SEVEN CONTINUES ON THE NEXT PAGE

Turn over ►

7.4 The coil is now rotated at twice the original speed. The oscilloscope settings are not changed.

What will the oscilloscope display look like now?

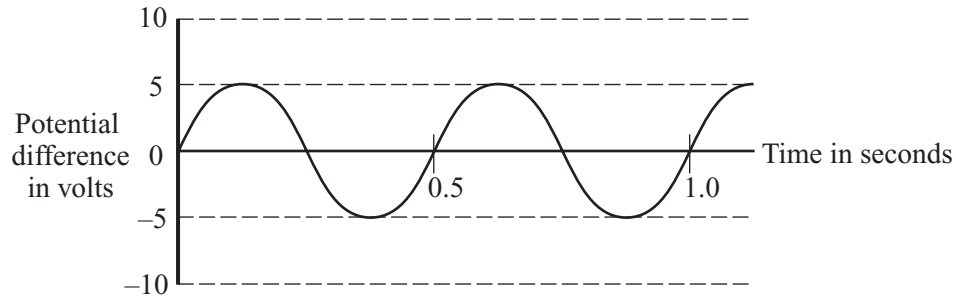
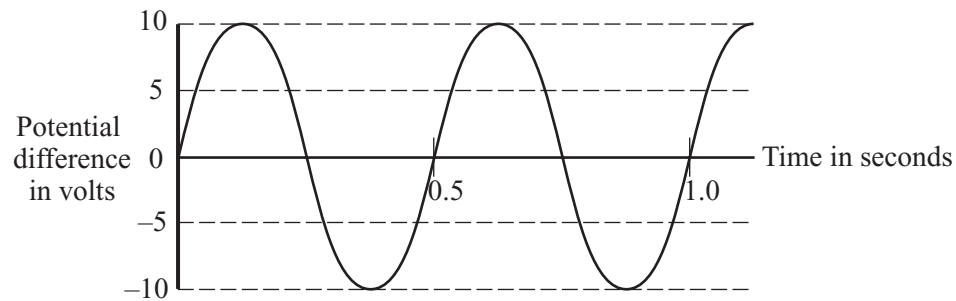
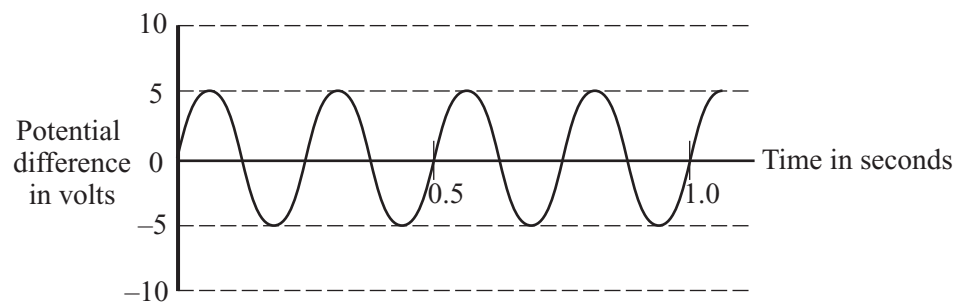
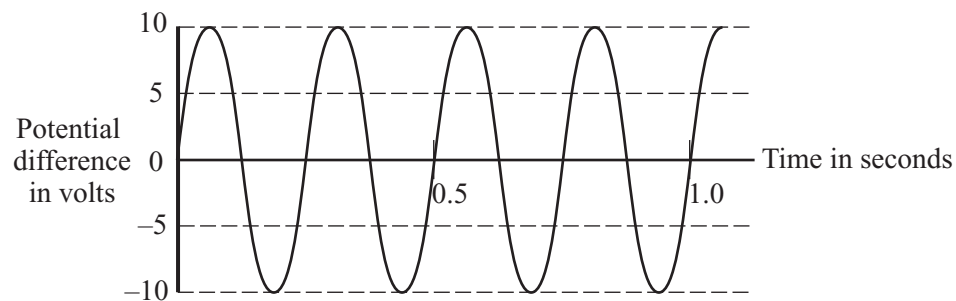
**A****B****C****D**

NO QUESTIONS APPEAR ON THIS PAGE

TURN OVER FOR THE NEXT QUESTION

Turn over ►

QUESTION EIGHT

A student is asked to set up a circuit to find the resistance of a fixed resistor.

The student is given a battery, an ammeter, a voltmeter, a variable resistor and the fixed resistor.

8.1 Which circuit **A**, **B**, **C** or **D** is connected correctly?

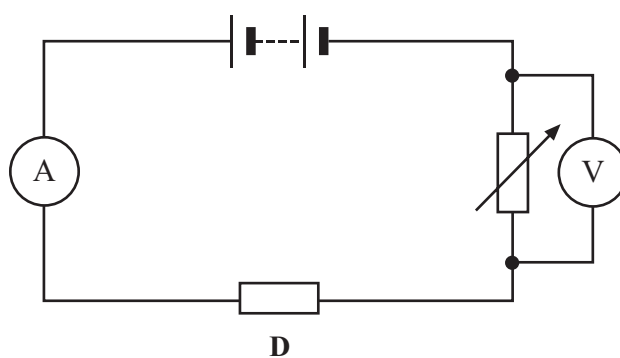
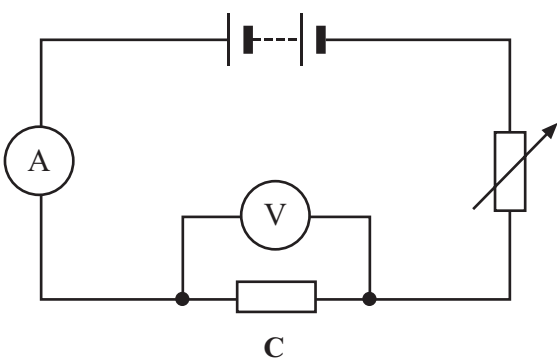
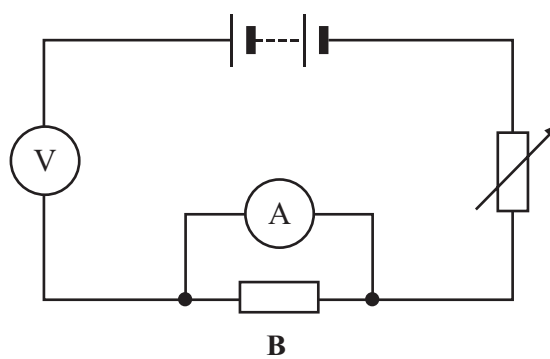
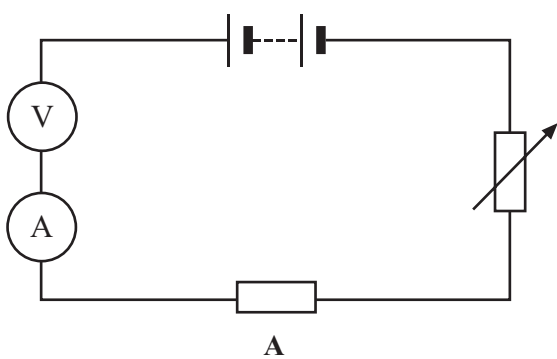

8.2 The student plotted the graph shown below.

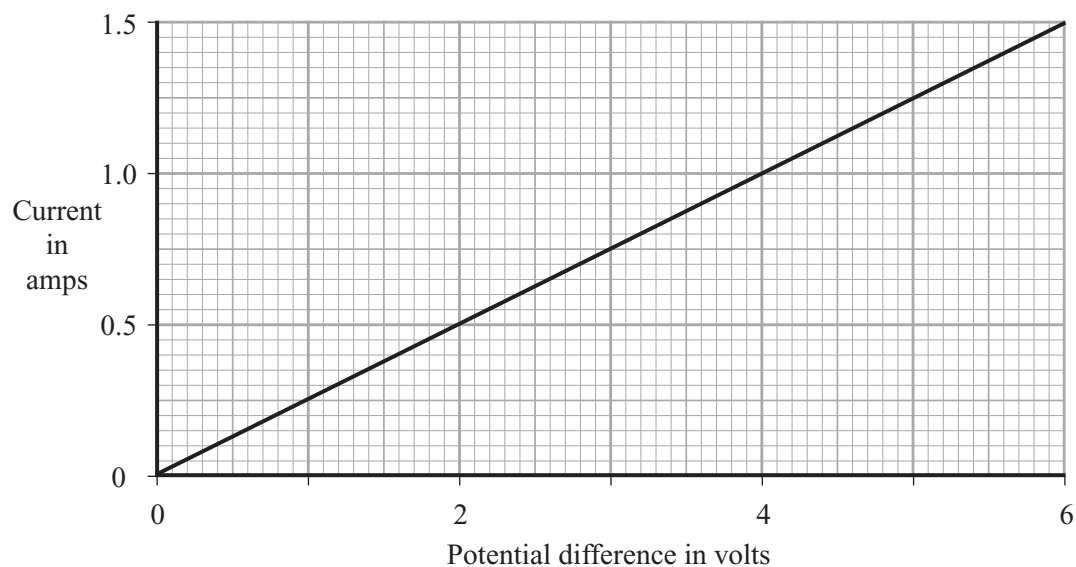

Which conclusion is correct?

- A The current is proportional to the potential difference
- B The current is inversely proportional to the potential difference
- C The resistance is proportional to the current
- D The resistance is inversely proportional to the current

8.3 What is the resistance of the fixed resistor in ohms?

- A 0.25
- B 2.50
- C 4.00
- D 9.00

8.4 In this experiment, the current is kept as low as possible because

- A large currents would cause the resistor to warm up which would alter its resistance.
- B only small currents can be measured accurately by ammeters.
- C only small currents can be provided by batteries.
- D only small potential differences can be measured accurately by voltmeters.

Turn over ►

QUESTION NINE

An African village is many miles away from a supply of mains electricity.

The Sun shines for at least a few hours nearly every day.

The villagers want a supply of electricity to pump up water from a well for a few hours each day.

The table shows the costs of two different ways of providing the electricity.

Way of providing electricity	Capital cost	Capital cost* (per kWh)	Fuel cost* (per kWh)	Maintenance cost* (per kWh)
Solar cells	£1000	20p	zero	zero
Petrol generator	£250	5p	20p	10p

(*These costs are averaged out over the 20 years that the equipment is expected to last.)

9.1 Which of the following statements is correct?

- A The petrol generator has a higher capital cost
- B The petrol generator has a higher capital cost per kWh
- C The petrol generator has a higher total cost per kWh
- D The petrol generator needs less maintenance

9.2 An advantage of the petrol generator is that

- A it is cheaper to set up the system in the first place.
- B it is less likely to break down.
- C it is quieter.
- D it will cause less air pollution.

9.3 A **disadvantage** of using the solar cells to generate electricity in the African village is that

- A they have a low capital cost.
- B they need no maintenance.
- C they will not work during the night.
- D they work out cheaper over a 20 year period.

- 9.4** If the same solar cells are used in the UK, they will produce only $\frac{1}{5}$ as much electricity during their 20 year life as they do in the African village.

How much more expensive is each Unit of electricity from the solar cells in the UK, than mains electricity at 8 p per Unit?

- A 2.5 times more expensive
- B 5 times more expensive
- C 10 times more expensive
- D 12.5 times more expensive

TURN OVER FOR THE NEXT QUESTION

Turn over ►

QUESTION TEN

You may find the following formulae useful when answering some parts of this question.

$$\text{efficiency} = \frac{\text{useful energy transferred by device}}{\text{total energy supplied to device}}$$

$$\begin{array}{l} \text{energy transferred} \\ \text{(joule, J)} \end{array} = \begin{array}{l} \text{power} \\ \text{(watt, W)} \end{array} \times \begin{array}{l} \text{time} \\ \text{(second, s)} \end{array}$$

$$\begin{array}{l} \text{change in gravitational potential energy} \\ \text{(joule, J)} \end{array} = \begin{array}{l} \text{weight} \\ \text{(newton, N)} \end{array} \times \begin{array}{l} \text{change in vertical height} \\ \text{(metre, m)} \end{array}$$

A clock is driven by a metal weight of mass 10 kg (weight 100 N).

The metal weight is wound up by hand, in a short time, through a vertical height of 5 m.

It then falls back down over a much longer time.

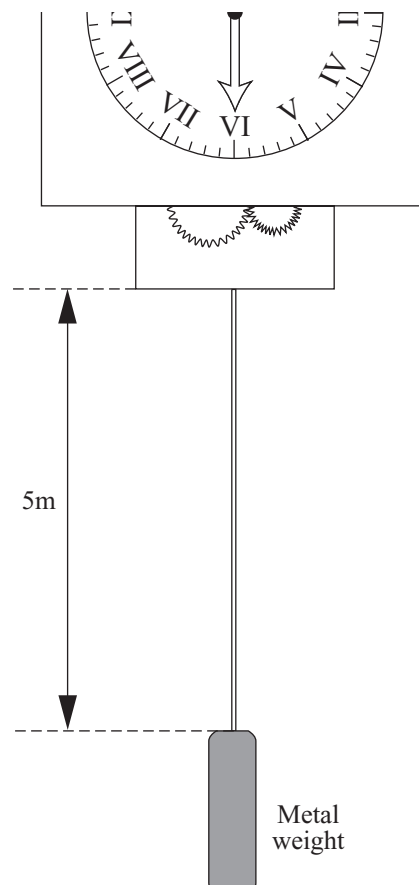

10.1 Assuming that the efficiency of energy transfer is 1 (100%), which line of the table is correct?

	Energy transferred by rise of metal weight	Power transferred by fall of metal weight
A	equal to energy supplied	greater than power supplied
B	equal to energy supplied	less than power supplied
C	greater than energy supplied	equal to power supplied
D	less than energy supplied	greater than power supplied

10.2 By how much does the metal weight's gravitational potential energy change when it is raised 5 m?

- A 50 J
- B 125 J
- C 500 J
- D 1250 J

Another, much larger, clock works in a similar way. However, the metal weight is raised automatically every day by an electric motor of efficiency 0.8 (80%).

The metal weight transfers 1000 J as it falls back down.

10.3 When the metal weight is raised, what is the total electrical energy transferred?

- A 800 J
- B 800 W
- C 1250 J
- D 1250 W

10.4 This metal weight falls back down in 24 hours.

What power is transferred to the clock?

- A 0.009 kWh
- B 0.009 W
- C 0.012 kWh
- D 0.012 W

END OF TEST

THERE ARE NO QUESTIONS PRINTED ON THIS PAGE

THERE ARE NO QUESTIONS PRINTED ON THIS PAGE

THERE ARE NO QUESTIONS PRINTED ON THIS PAGE