

Surname		Other Names	
Centre Number		Candidate Number	
Candidate Signature			

Leave blank

General Certificate of Secondary Education
June 2006

**SCIENCE: SINGLE AWARD A (MODULAR)
Foundation Tier**

3469/F
F



Wednesday 7 June 2006 1.30 pm to 3.00 pm

<p>For this paper you must have:</p> <ul style="list-style-type: none"> the Data Sheet (enclosed) a ruler <p>You may use a calculator.</p>

Time allowed: 1 hour 30 minutes

Instructions

- Use blue or black ink or ball-point pen.
- Fill in the boxes at the top of this page.
- Answer **all** questions.
- Answer the questions in the spaces provided.
- Do all rough work in this book. Cross through any work you do not want marked.

Information

- The maximum mark for this paper is 90.
- The marks for questions are shown in brackets.
- You are reminded of the need for good English and clear presentation in your answers.

For Examiner's Use			
Number	Mark	Number	Mark
1		9	
2		10	
3		11	
4		12	
5		13	
6		14	
7		15	
8		16	
Total (Column 1) →			
Total (Column 2) →			
TOTAL			
Examiner's Initials			

ENVIRONMENT, INHERITANCE AND SELECTION

- 1 (a) The drawing shows the fossil remains of an ancestor of the modern horse.



- (i) Name **one** material in which fossils are formed.

.....
(1 mark)

- (ii) The bones are the only parts of this animal which remain.

What has happened to the rest of the animal?

.....
.....
(1 mark)

(b) The drawing shows a horse and some of its extinct ancestors.

The drawing also shows the foot bones of each animal.

All the animals are drawn to the same scale.

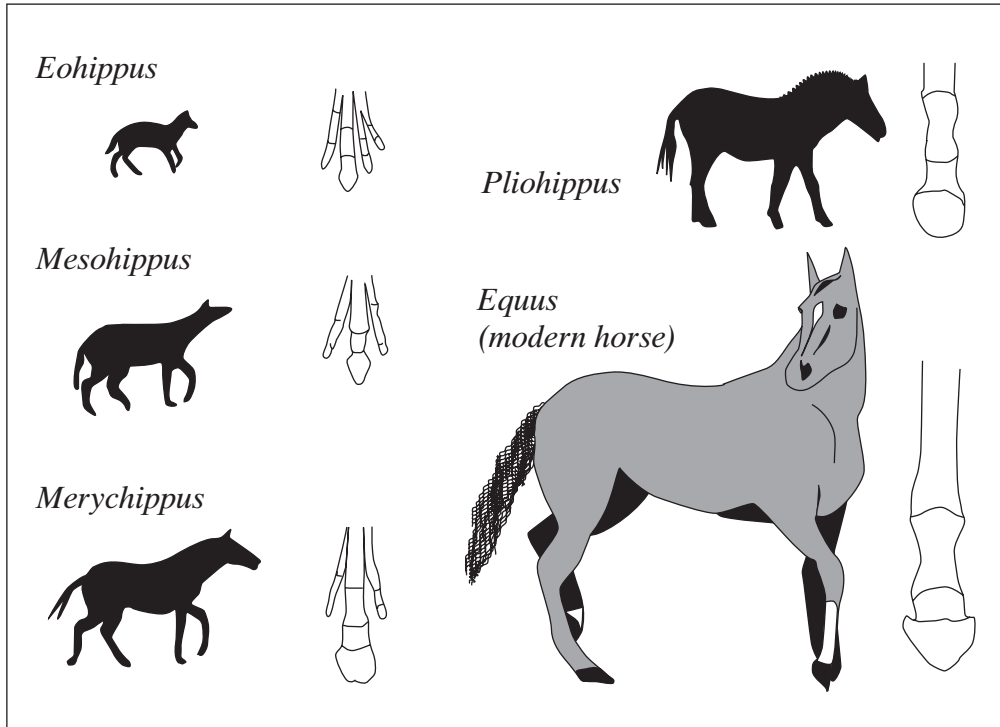

(i) Which of these animals was probably the first to evolve?

.....
(1 mark)

(ii) From the drawings, give **two** differences between the foot bones of *Mesohippus* and *Pliohippus*.

1

.....

2

.....

(2 marks)

2 The diagram shows some of the parts of an egg cell. There is also an enlarged view of structure Q.

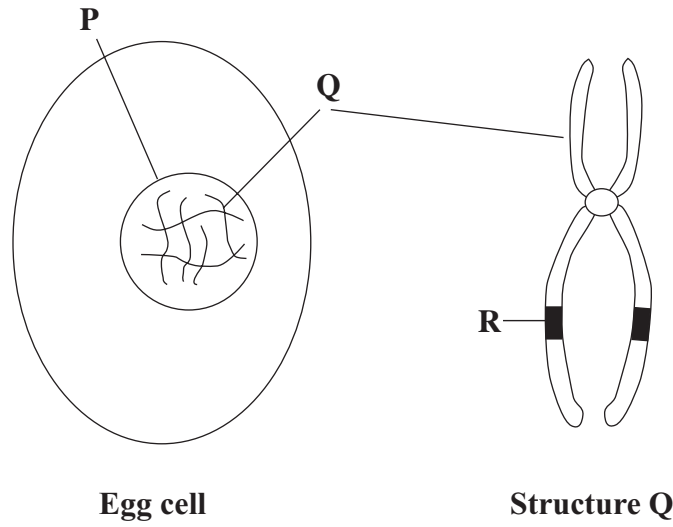

(a) Use words from the box to name the structures labelled P, Q and R.

cell membrane chromosome cytoplasm gene nucleus

P

Q

R

(3 marks)

(b) Use words from the box to complete the sentences about hormones.

antibiotic contraceptive fertility ovary stomach womb

Hormones control the release of eggs from the

Hormones also control the thickness of the lining of the

Hormones that stimulate the release of eggs can be used as drugs.

Hormones that prevent the release of eggs can be used as drugs.

(4 marks)

PATTERNS AND REACTIONS

- 3 (a) The diagram shows part of the periodic table.

													0	
1	2								3	4	5	6	7	He
Li										C			F	
	Mg													
K							Fe						Br	
								Ag						

From the elements in the table above, write the symbol of one which:

- (i) is much less dense than air;
- (ii) is a liquid with a coloured vapour;
- (iii) is the least reactive alkali metal;
- (iv) is the most reactive halogen.

(4 marks)

- (b) Complete the sentences about the properties of most **non-metallic** elements.

They have boiling points.

They are conductors of electricity.

(2 marks)

- (c) Use words from the box to complete the sentences about the periodic table.

energy level	group	mass	number	period	shell	size
---------------------	--------------	-------------	---------------	---------------	--------------	-------------

The modern periodic table is an arrangement of the elements in order of increasing atomic

Each row of the table is called a

Each column of the table is called a

(3 marks)

9

Turn over ▶

4 The diagrams show hazard symbols. These are printed on some household products.

Draw a straight line from each hazard symbol to the product on which you would find it.



Bleach which
irritates skin



Oven cleaner which
destroys skin



Barbecue lighting
fuel



Poisonous
weed killer

(3 marks)

3

FORCES, WAVES AND RADIATION

- 5 The diagram shows a light ray entering a glass block.

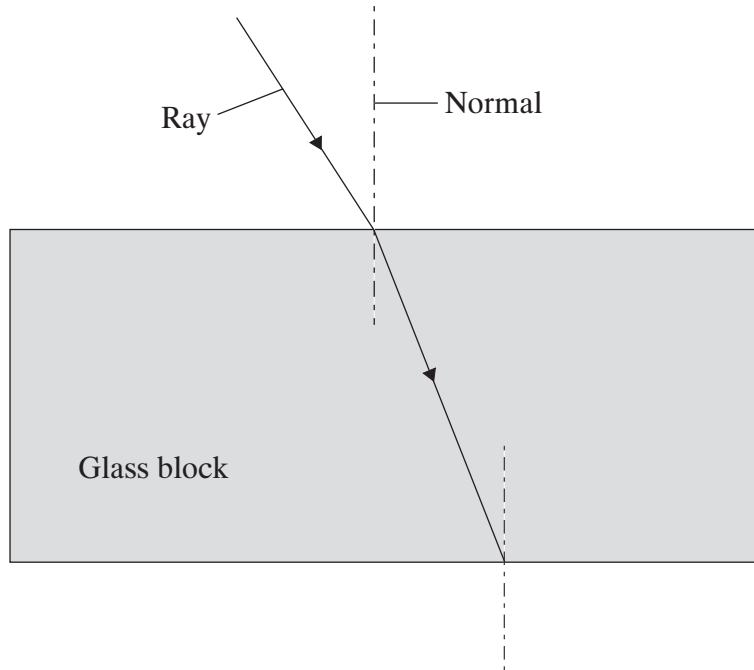

- (a) Draw the path taken by the ray of light as it leaves the block. (2 marks)
- (b) Use words from the box to complete the sentences.

amplitude	diffraction	pitch	reflection	refraction	speed
------------------	--------------------	--------------	-------------------	-------------------	--------------

The ray of light changes direction when it enters the glass block because its
..... changes.

This change of direction is called

(2 marks)

- (c) Describe **one** use of infra red waves.

.....
.....

(1 mark)

6 (a) The table shows the electromagnetic spectrum.

	X-rays		light		micro-waves	
--	---------------	--	--------------	--	--------------------	--

highest frequency ←————→ lowest frequency

Use words from the box to complete the table.

gamma rays infra red waves radio waves ultraviolet rays

(3 marks)

(b) The drawing shows someone sunbathing on a beach.



Explain, as fully as you can, why you should not spend too much time in the sun.

To gain full marks for this question you should write your ideas in good English. Put them into a sensible order and use the correct scientific words.

.....

.....

.....

.....

.....

.....

(4 marks)

7

QUESTIONS RELATING TO PREVIOUSLY TESTED MODULES

7 The diagram shows a simple circuit.

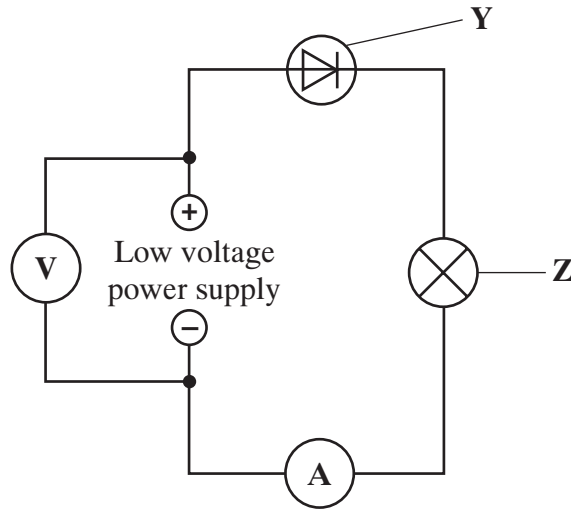

(a) Name the components labelled:

Y;

Z.

(2 marks)

(b) Name the component which is used to measure the current in the circuit.

.....
(1 mark)

(c) The current in the circuit is 0.2 A.

What will the current be if component **Y** is connected the other way round?

.....
.....
(1 mark)

- 8 (a) The table shows the compounds and ions dissolved in a student's urine.

Compound or ion	Percentage of total
Urea	60
Negative ions	25
Positive ions	10
Other nitrogen-containing substances	5

Complete the pie chart for the compounds and ions dissolved in urine.

One sector has been completed for you. Do not forget to label the chart.

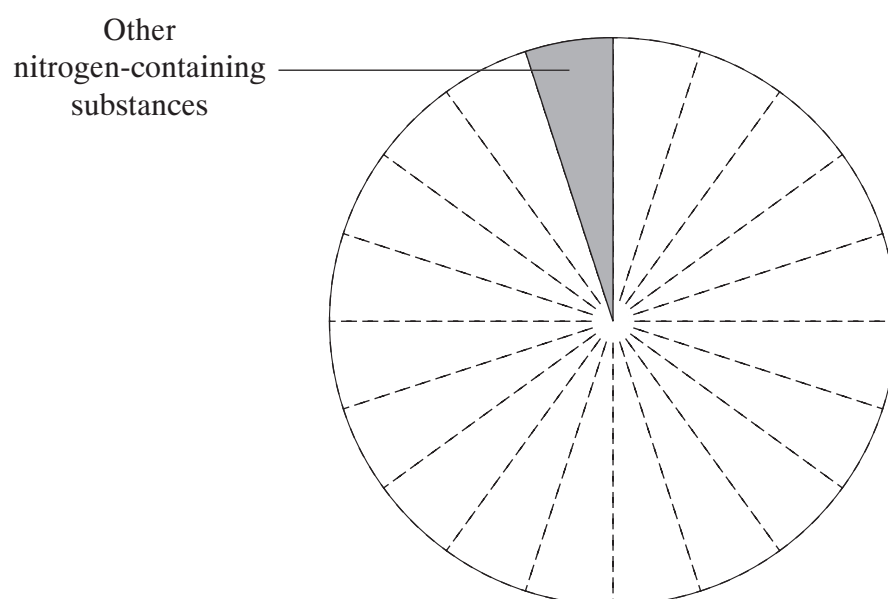

(3 marks)

(b) Use words from the box to complete the sentences about waste products.

bladder kidneys intestine liver lungs skin stomach

Sweat is produced by the

Carbon dioxide leaves the body via the

Urea is made in the

Urine is made in the

Urine is stored in the

(5 marks)

8

Turn over for the next question

Turn over ►

ENVIRONMENT, INHERITANCE AND SELECTION

- 9 The drawing shows a penguin. Penguins live in the Antarctic. They swim underwater to catch fish.

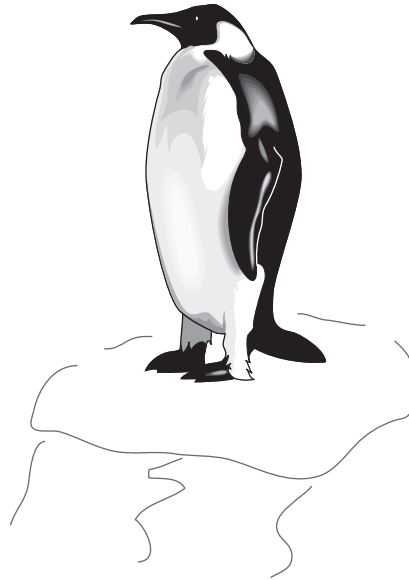

These are some facts about penguins. They have:

- a thick layer of fat underneath the skin
- heavy, solid bones that act like a diver's weight belt
- wings shaped like flippers
- stiff, tightly packed feathers
- feathers coated with oil from a gland near the tail
- a streamlined body
- feet that resemble paddles.

- (a) Give **two** adaptations of penguins for surviving in cold conditions.

1

.....

2

.....

(2 marks)

(b) Give **two** adaptations of penguins for catching fish.

1

.....

2

.....

(2 marks)

4

Turn over for the next question

Turn over ►

10 The diagram shows some stages in sexual reproduction in humans.

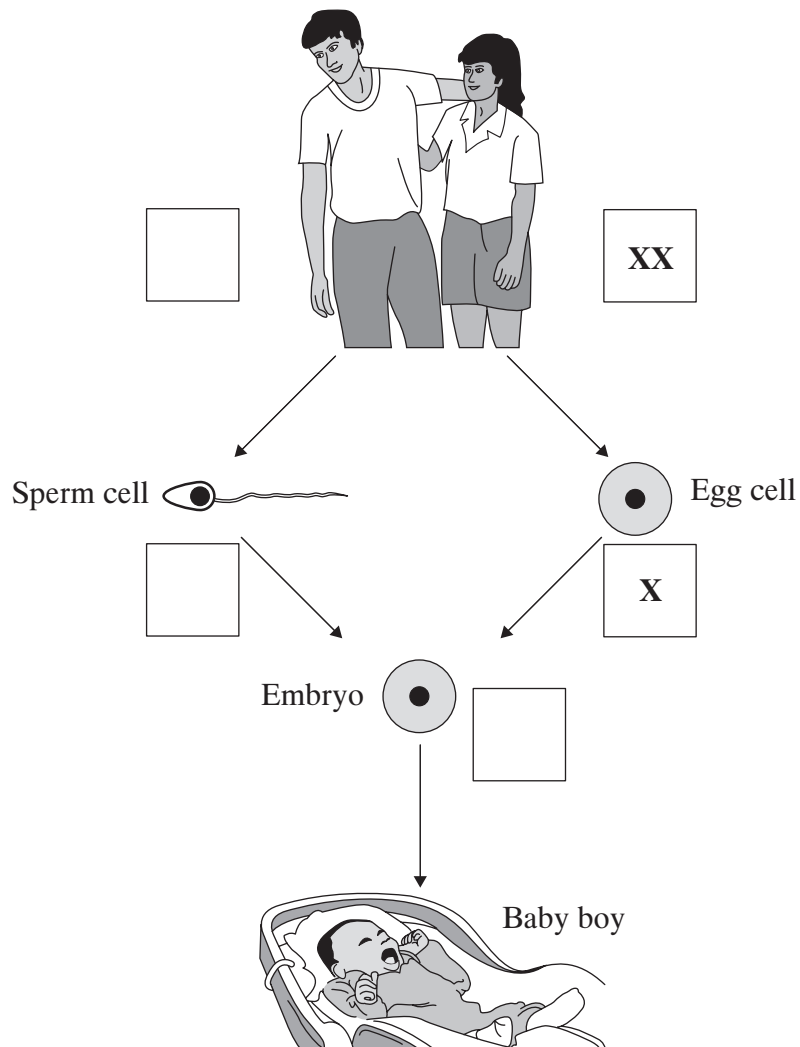

(a) The box for the woman shows her chromosomes.

On the diagram, write the sex chromosomes which should be in the empty boxes.

(3 marks)

(b) The child has inherited cystic fibrosis from its parents.

Neither parent has cystic fibrosis.

Explain, as fully as you can, how the child has inherited cystic fibrosis.

To gain full marks for this question you should write your ideas in good English. Put them into a sensible order and use the correct scientific words.

.....

.....

.....

.....

.....

.....

(4 marks)

7

Turn over for the next question

Turn over ►

PATTERNS AND REACTIONS

- 11** The graph shows how the boiling points of the Group 0 elements are related to their atomic numbers.

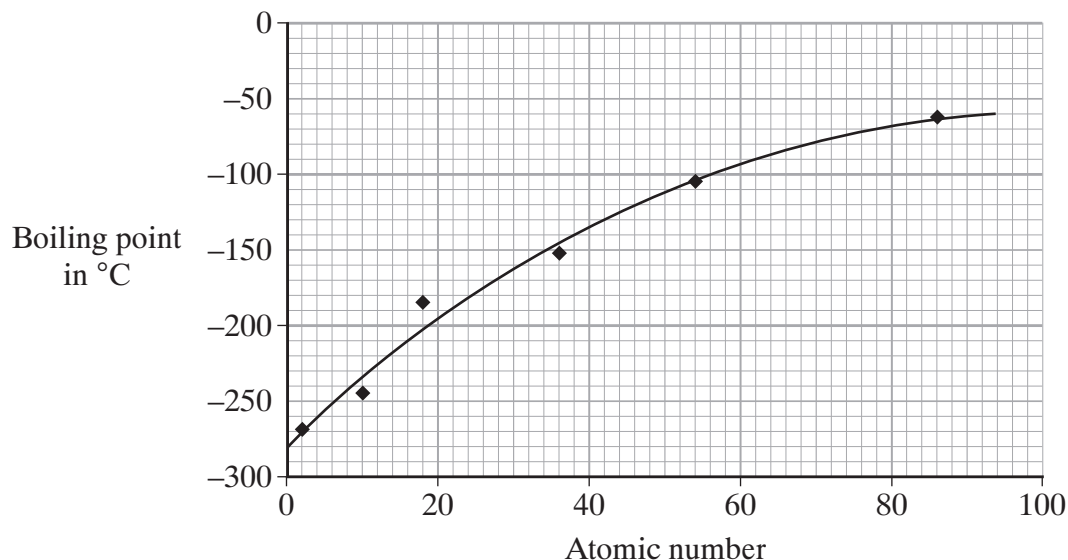

Use the periodic table on the Data Sheet to help you to answer these questions.

- (a) What is the state of radon at room temperature? (1 mark)
- (b) What is the boiling point of krypton? °C (1 mark)
- (c) Describe the trend in the boiling points of the Group 0 elements.

.....

.....

.....

.....

(2 marks)

- (d) Use dots or crosses to complete the diagram of the electronic structure of a neon atom.

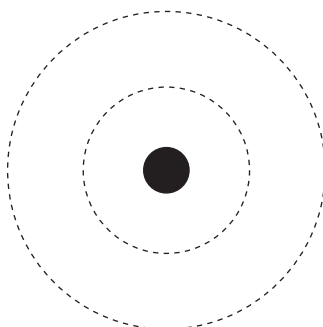

(2 marks)

- 12 (a) The diagram shows how wine can be made at home by fermenting grape juice.

Grape juice contains sugar.

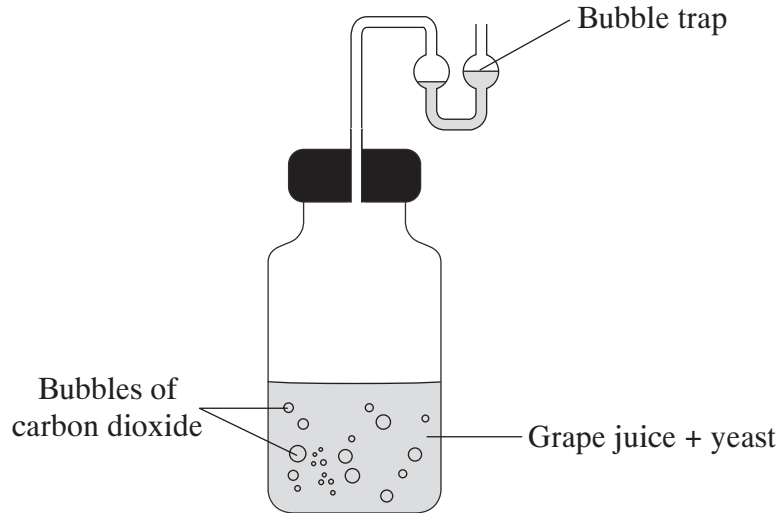

Write a word equation for fermentation

..... → +
(2 marks)

- (b) Name the type of enzyme used in industry to 'pre-digest' proteins in some baby foods.

.....
(1 mark)

3

Turn over for the next question

Turn over ►

FORCES, WAVES AND RADIATION

- 13** The pie chart shows the average amount of background radiation that a person receives each year.

Amount of background radiation in mrem per year

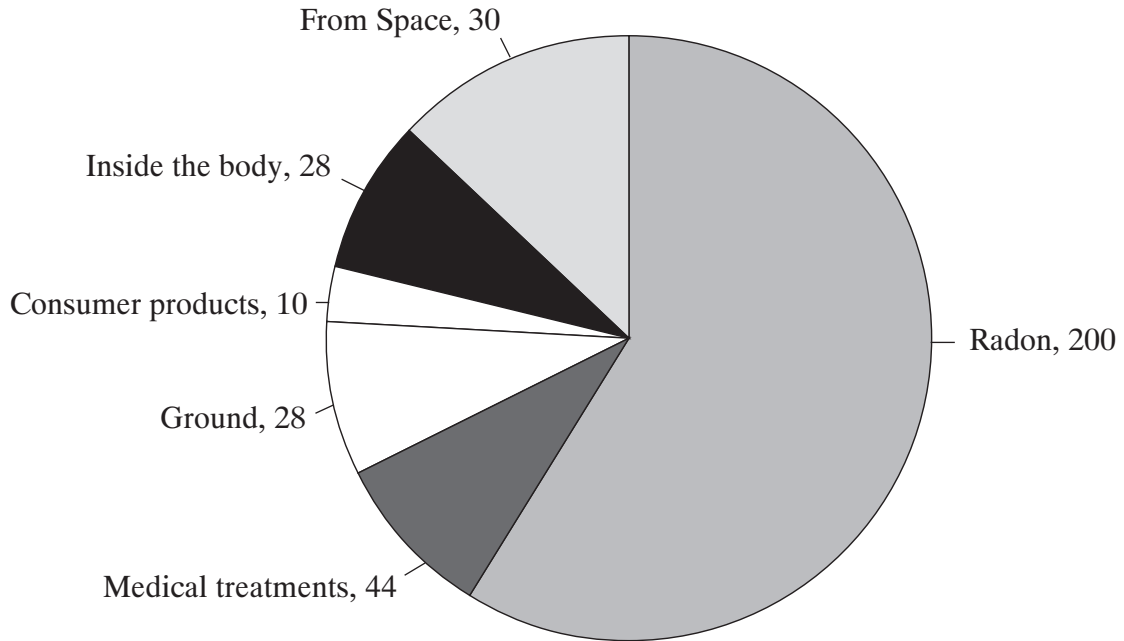

- (a) Calculate the proportion of background radiation which comes from radon.

Show your working.

.....

Proportion of radon

(2 marks)

(b) Name **three** types of radiation which may be emitted by radioactive sources.

..... and and (1 mark)

(c) Which type of radiation is the most dangerous when the radioactive source is **outside** the body?

.....

Why is this type of radiation the most dangerous?

.....

.....

(2 marks)

5

Turn over for the next question

Turn over ►

- 14 The diagram shows the results of an experiment carried out by a team of scientists led by Ernest Rutherford. They fired alpha particles at very thin pieces of gold leaf.

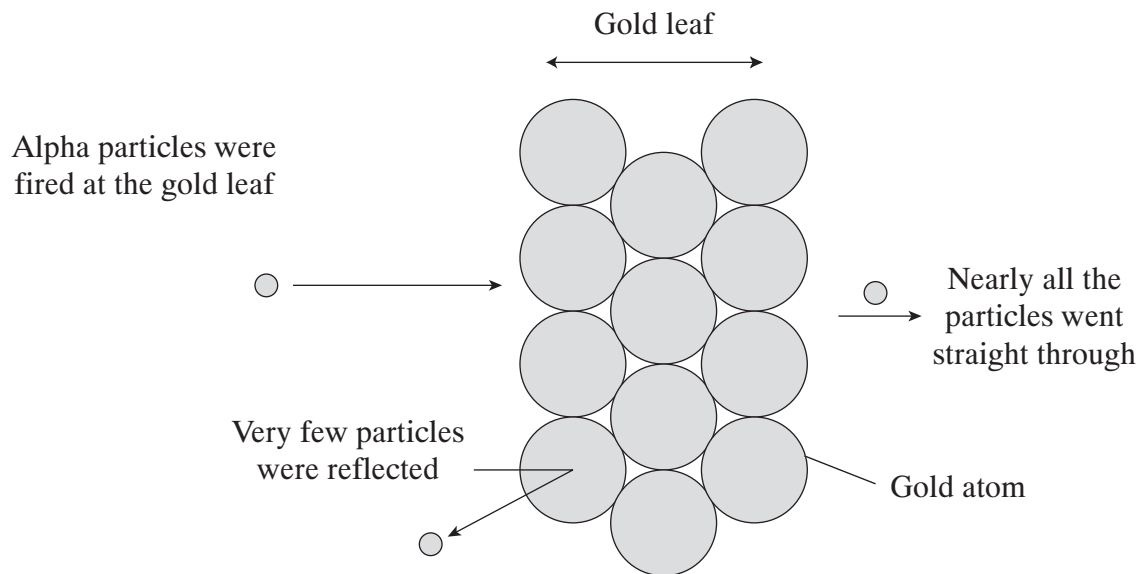

- (a) Most of the alpha particles went straight through the atoms in the gold leaf.

What did this tell Rutherford about gold atoms?

.....

(1 mark)

- (b) Alpha particles are positively charged. A few alpha particles were reflected by the atoms in the gold leaf.

Explain why.

.....

(1 mark)

- (c) Many experiments since Rutherford's have given us more evidence about the structure of the atom.

Describe the structure of an atom.

.....

.....

.....

.....

.....

.....

(3 marks)

5

Turn over for the next question

Turn over ►

QUESTIONS RELATING TO PREVIOUSLY TESTED MODULES

- 15** The table shows the mass of carbohydrate, fat and protein in five different foods, **A** to **E**.

Food	Mass in 100 g of food in g		
	Carbohydrate	Fat	Protein
A	0	1	20
B	50	12	8
C	0	42	0
D	12	1	0
E	20	0	2

- (a) Calculate the mass of carbohydrate in a 40 g portion of food **E**.

Show your working.

.....

.....

.....

Mass = g
(2 marks)

- (b) Carbohydrates and proteins release about the same amount of energy in the body.

Fats release about twice as much energy as carbohydrates and proteins.

Which food, **B** or **C**, releases most energy in the body?

Food

Show your working.

.....

.....

(2 marks)

(c) Describe what happens to food in the small intestine.

You are **not** required to give the names of any enzymes.

.....

.....

.....

.....

(3 marks)

7

Turn over for the next question

Turn over ►

16 Useful products are obtained from crude oil.

(a) Describe how crude oil is separated into different fractions by fractional distillation.

.....

.....

.....

.....

.....

.....

(3 marks)

(b) The diagram shows the percentages of different fractions produced from crude oil.

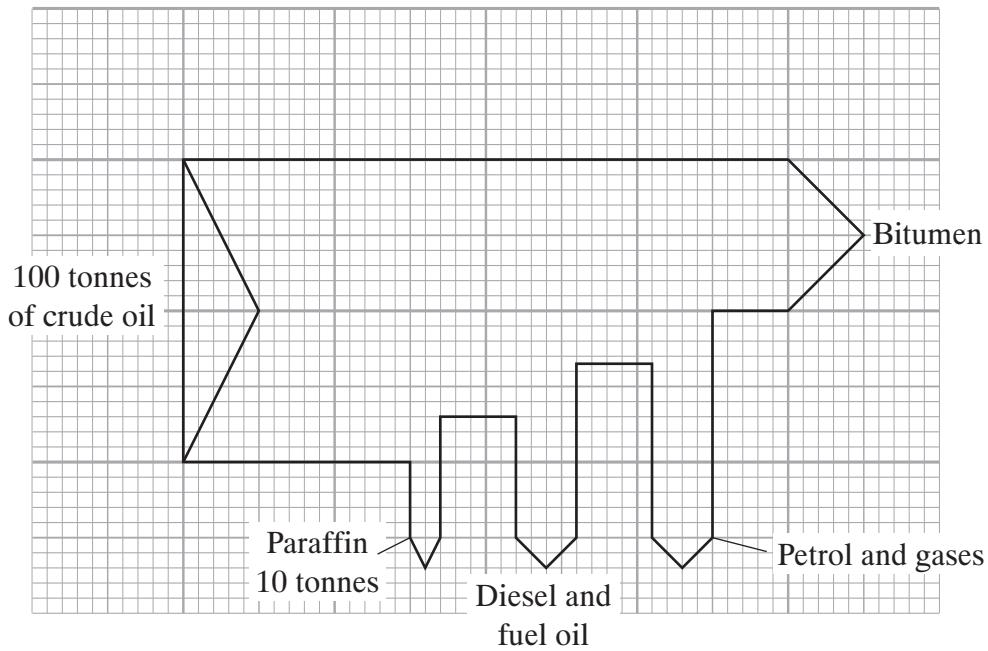

How many tonnes of **each** of the following would be obtained from 100 tonnes of crude oil?

(i) Diesel and fuel oil

..... tonnes

(ii) Bitumen

..... tonnes

(2 marks)

5

END OF QUESTIONS