

Surname					Other Names				
Centre Number					Candidate Number				
Candidate Signature									

General Certificate of Secondary Education  
Spring 2003



**SCIENCE: SINGLE AWARD (MODULAR)  
Energy and Electricity (Module 17)**

**346017**

Wednesday 5 March 2003 Morning Session

**In addition to this paper you will require:**

- an HB pencil and a rubber;
- an answer sheet.

You may use a calculator.

Time allowed: 30 minutes

Copyright © 2003 AQA and its licensors. All rights reserved.

**Instructions**

- Fill in the boxes at the top of this page.
- Check that your name, candidate number and centre number are printed on the separate answer sheet.
- Check that the separate answer sheet has the title “Energy and Electricity” printed on it.
- Attempt **one Tier only, either** the Foundation Tier **or** the Higher Tier.
- Answer **all** the questions for the Tier you are attempting.
- Make sure that you use the correct side of the separate answer sheet; the Foundation Tier is printed on one side and the Higher Tier on the other.
- Mark your responses on the separate answer sheet only. Rough work may be done on the question paper.
- Mark the best responses by using a thick pencil stroke to fill in the box. Use an HB pencil. Make sure the pencil stroke does **not** extend beyond the box. Do **not** use ink or ball-point pen. If you wish to change your answer, rub out your first answer completely. See below.

**Examples:**

	1	2	3	4
	<input type="checkbox"/>	<input type="checkbox"/>	<input checked="" type="checkbox"/>	<input type="checkbox"/>
	<input type="checkbox"/>	<input checked="" type="checkbox"/>	<input type="checkbox"/>	<input type="checkbox"/>
	<input type="checkbox"/>	<input type="checkbox"/>	<input type="checkbox"/>	<input checked="" type="checkbox"/>
	<input checked="" type="checkbox"/>	<input type="checkbox"/>	<input type="checkbox"/>	<input type="checkbox"/>

<input checked="" type="checkbox"/>
<input type="checkbox"/>
<input type="checkbox"/>
<input checked="" type="checkbox"/>
<input type="checkbox"/>

QUESTION XXX				
xxx.1	<input type="checkbox"/> A	<input checked="" type="checkbox"/> B	<input type="checkbox"/> C	<input type="checkbox"/> D
xxx.2	<input type="checkbox"/> A	<input type="checkbox"/> B	<input type="checkbox"/> C	<input checked="" type="checkbox"/> D
xxx.3	<input type="checkbox"/> A	<input checked="" type="checkbox"/> B	<input type="checkbox"/> C	<input type="checkbox"/> D
xxx.4	<input checked="" type="checkbox"/> A	<input type="checkbox"/> B	<input type="checkbox"/> C	<input type="checkbox"/> D

**Information**

- The maximum mark for this paper is 36.

**Advice**

- Do **not** choose more responses than you are asked to. You will lose marks if you do.
- Make sure that you hand in both your answer sheet and this question paper at the end of the test.
- If you start to answer on the wrong side of the answer sheet by mistake, make sure that you rub out **completely** the work that is not to be marked.

---

You must do **one Tier** only, **either** the Foundation Tier **or** the Higher Tier.  
The Higher Tier starts on page 14 of this booklet.

---

**FOUNDATION TIER**

**SECTION A**

Questions **ONE** to **FIVE**.

In these questions match the words in the list with the numbers.

Use **each** answer only **once**.

Mark your choices on the answer sheet.

---

**QUESTION ONE**

These devices are designed to transfer electrical energy.

Match words from the list with the spaces **1–4** in the sentences.

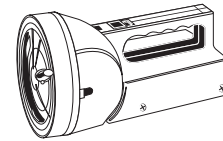
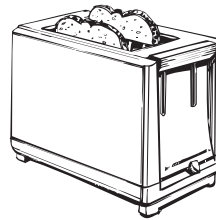
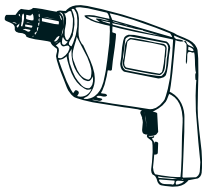

**heat (thermal energy)**

**light**

**movement (kinetic energy)**

**sound**

The drill is designed to transfer electrical energy as . . . . . **1** . . . . .

The radio is designed to transfer electrical energy as . . . . . **2** . . . . .

The toaster is designed to transfer electrical energy as . . . . . **3** . . . . .

The torch is designed to transfer electrical energy as . . . . . **4** . . . . .

**QUESTION TWO**

Symbols are used in circuit diagrams.

Match the names from the list with each of the symbols 1–4.

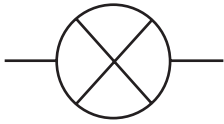

1

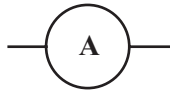

2

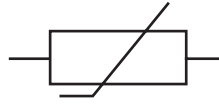

3

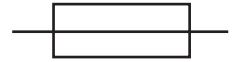

4

**ammeter****fuse****lamp****thermistor****QUESTION THREE**

The diagram shows one way in which electricity can be generated.

Match the words in the list with each of the spaces 1–4 in the sentences.

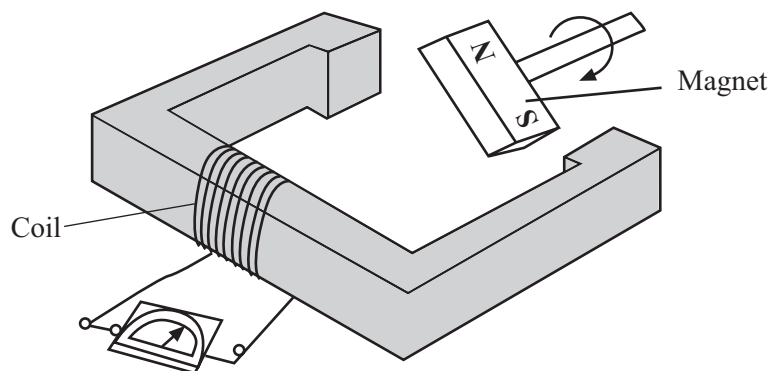
**coil****current****field****magnet**

The ..... 1 ..... is rotated.

This causes a changing magnetic ..... 2 .....

A voltage is induced across the ..... 3 ....., causing a ..... 4 ..... in the circuit.

**Turn over ►**

## QUESTION FOUR

You may find the following formulae useful when answering this question.

$$\begin{array}{ccccc} \text{energy transferred} & = & \text{power} & \times & \text{time} \\ \text{(kilowatt-hour, kWh)} & & \text{(kilowatt, kW)} & & \text{(hour, h)} \end{array}$$

$$\text{total cost} = \text{number of Units} \times \text{cost per Unit}$$

An electric kettle has a power of 2750 watts.

Match numbers from the list with the spaces **1–4** in the sentences.

2.75

8.25

108

2750

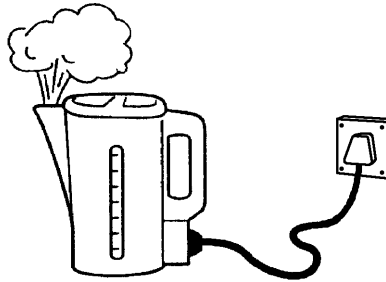

The power of the kettle in kilowatts is ..... **1** .....

The number of kilowatt-hours transferred by the kettle in 3 hours is ..... **2** .....

The kettle transfers 12 Units of electricity per week. One Unit of electricity costs 9p.  
The total cost of this electricity is ..... **3** ..... p.

The number of joules of energy transferred by the kettle in one second is ..... **4** .....

### QUESTION FIVE

The diagram shows part of a solar-powered power station.

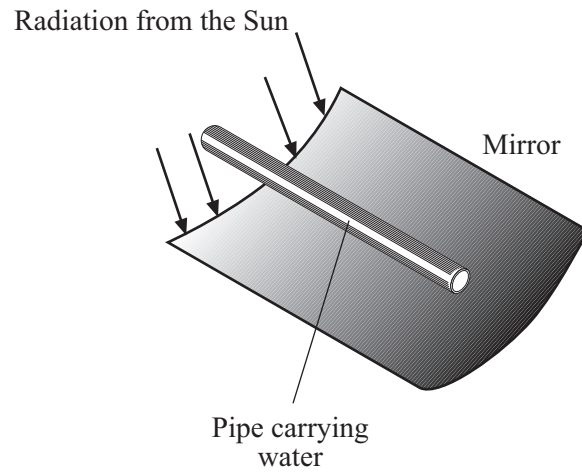

Match words from the list to fill the boxes 1–4, to explain how the power station works.

**a turbine turns a generator**

**radiation is reflected onto the pipe**

**steam drives a turbine**

**water absorbs radiation**

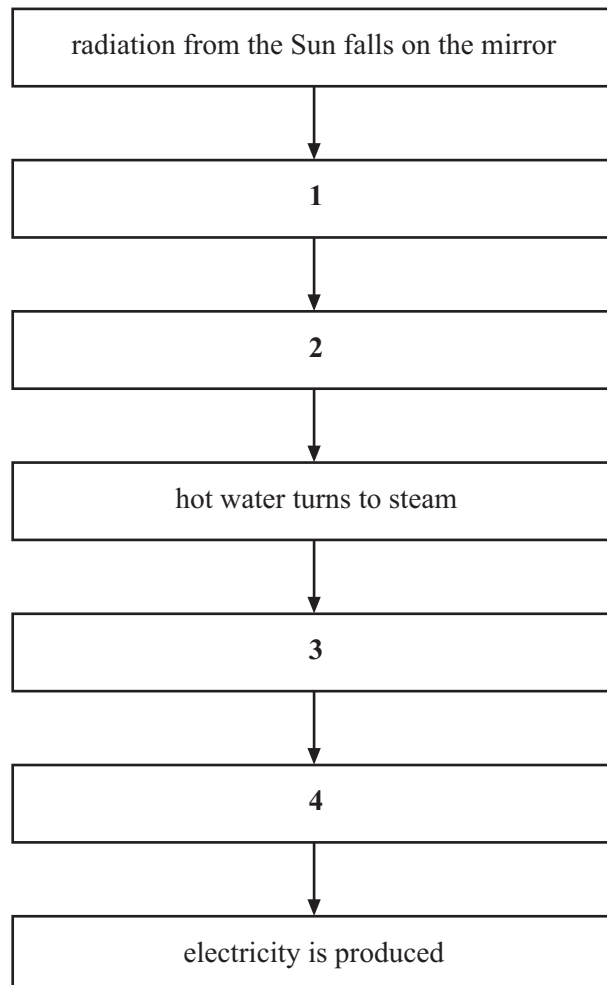

**Turn over ►**

**SECTION B**Questions **SIX** and **SEVEN**.In these questions choose the best **two** answers.Do **not** choose more than two.Mark your choices on the answer sheet.

---

**QUESTION SIX**

Power stations use energy sources to generate electricity.

Which **two** types of power station use fossil fuels to generate electricity?**coal-fired****hydroelectric****nuclear****oil-fired****tidal barrage**

**QUESTION SEVEN**

The circuit has three identical ammeters,  $A_1$ ,  $A_2$  and  $A_3$ .

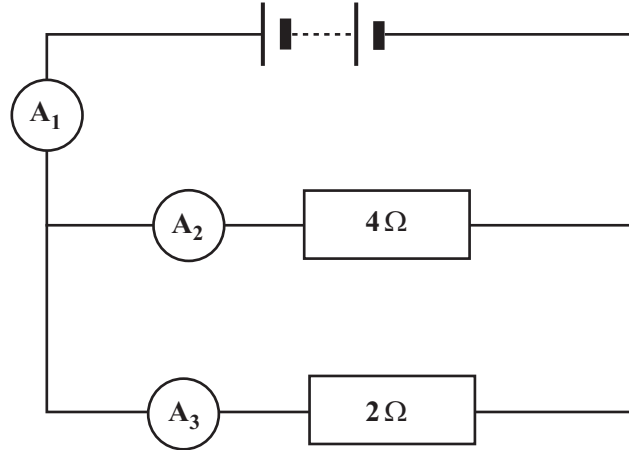

Which **two** statements, **J**, **K**, **L**, **M** or **N**, are correct?

- J** all the ammeters have the same reading
- K** the reading on ammeter  $A_3$  is greater than that on  $A_2$
- L** the reading on ammeter  $A_2$  is greater than that on  $A_3$
- M** the reading on ammeter  $A_2$  is identical to that on  $A_3$
- N** the reading on ammeter  $A_1$  is the sum of the readings on  $A_2$  and  $A_3$

**TURN OVER FOR THE NEXT QUESTION**

**Turn over ►**

---

**SECTION C**Questions **EIGHT** to **TEN**.

Each of these questions has four parts.

In each part choose only **one** answer.Mark your choices on the answer sheet.

---

**QUESTION EIGHT**

The circuit shows a lamp of resistance 6 ohms, connected in series with a variable resistor **R**, a battery and a switch. When we set **R** to zero and close the switch, the current through the lamp is 2 A.

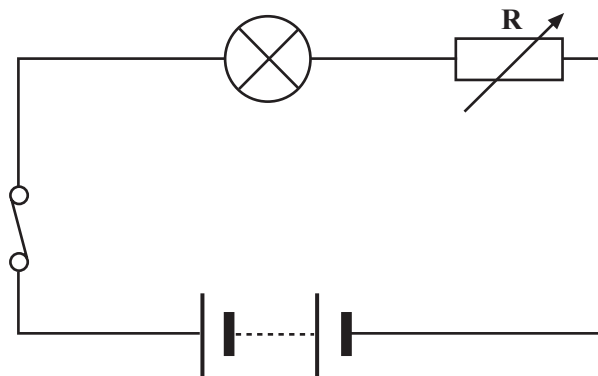

**8.1** What is the potential difference (voltage) across the battery?

- A** 0.33 V
- B** 3 V
- C** 12 V
- D** 24 V

**8.2** The battery is now changed to one of 10 V and **R** is increased from zero to exactly the same resistance as the lamp.

What will be the new potential difference (voltage) across the lamp?

- A** 5 V
- B** 6 V
- C** 10 V
- D** 20 V



**8.3** **R** is now increased gradually from zero.

The resistance of the lamp will . . . . .

- A** fall because the current in the lamp will be higher.
- B** fall because the lamp will get cooler.
- C** rise because the lamp will get hotter.
- D** stay the same because the battery voltage is constant.

**8.4** The circuit is now changed, so that the variable resistance **R** is in parallel with the lamp.

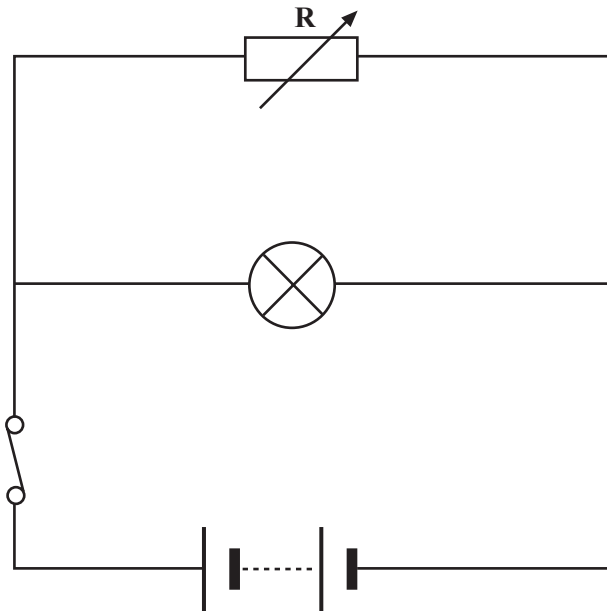

What will be the potential difference (voltage) across the lamp?

- A** Double that across the battery
- B** Half that across the battery
- C** It depends on the value of **R**
- D** The same as that across the battery

### QUESTION NINE

All the cells, lamps and diodes in these circuits are identical. Decide which lamps light in the different arrangements before you answer the questions.

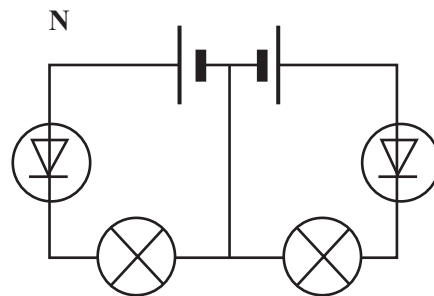
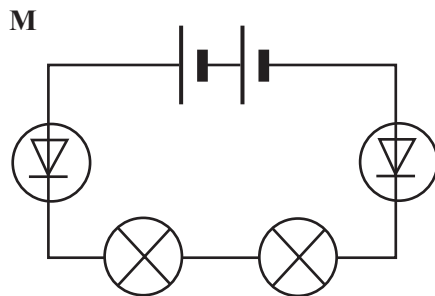
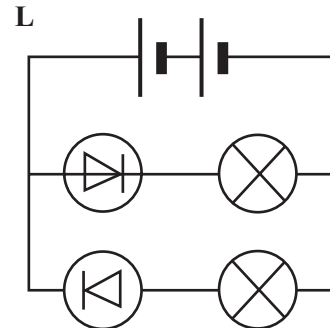
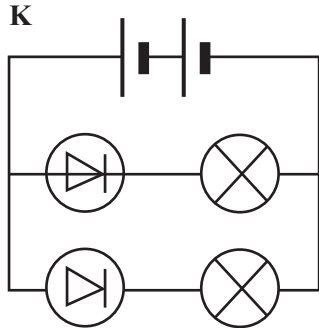

9.1 Neither lamp lights in . . . . .

- A circuit **K** only.
- B circuits **K**, **L** and **M**.
- C circuits **M** and **N**.
- D circuit **M** only.

9.2 Only one lamp lights in . . . . .

- A circuit **K** only.
- B circuits **K** and **M**.
- C circuits **L** and **N**.
- D circuit **L** only.

**9.3** Both lamps light in . . . . .

- A** circuit **K** only.
- B** circuits **K** and **N**.
- C** circuits **L** and **M**.
- D** circuit **M** only.

**9.4** In which circuit do the cells run down most quickly?

- A** Circuit **K**
- B** Circuit **L**
- C** Circuit **M**
- D** Circuit **N**

**TURN OVER FOR THE NEXT QUESTION**

**Turn over ►**

**QUESTION TEN**

This question is about the energy resources used in power stations.

**10.1** The source of energy for geothermal power stations is . . . . .

- A combustion.
- B decay of radioactive elements.
- C movement of air.
- D movement of water.

**10.2** The gas mainly responsible for producing acid rain is . . . . .

- A natural gas.
- B nitrogen.
- C oxygen.
- D sulphur dioxide.

**10.3** What is the main advantage of a tidal barrage over a wind farm?

- A More power is produced at times of high demand
- B More power is produced in winter than in summer
- C There are no environmental impacts
- D The times and outputs for each day can be forecast

**10.4** 700 000 kilowatts of power are produced when 100 tonnes of coal are burned in 1 hour.

How quickly must the coal be burned to produce 7 000 000 kilowatts?

- A 10 tonnes / hour
- B 70 tonnes / hour
- C 100 tonnes / hour
- D 1000 tonnes / hour

**END OF TEST**

---

You must do **one Tier** only, **either** the Foundation Tier **or** the Higher Tier.  
The Foundation Tier is earlier in this booklet.

---

### HIGHER TIER

#### SECTION A

Questions **ONE** and **TWO**.

In these questions match the words in the list with the numbers.

Use **each** answer only **once**.

Mark your choices on the answer sheet.

---

#### QUESTION ONE

The diagram shows part of a solar-powered power station.

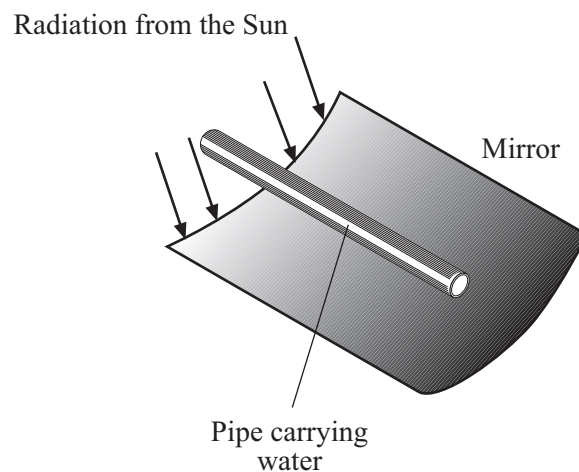

Match words from the list to fill the boxes **1–4**, to explain how the power station works.

**a turbine turns a generator**

**radiation is reflected onto the pipe**

**steam drives a turbine**

**water absorbs radiation**

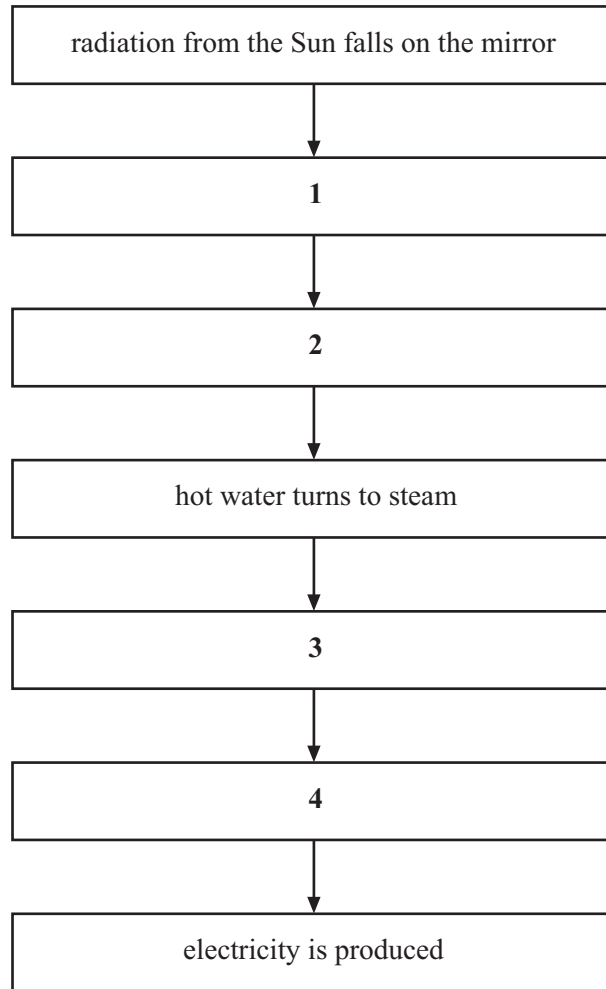

**TURN OVER FOR THE NEXT QUESTION**

**Turn over ►**

**QUESTION TWO**

A swimmer climbs up to a diving board, then dives into the water.

Match words from the list with the spaces **1–4** in the sentences.

**gravitational potential energy**

**kinetic energy**

**thermal energy**

**weight**

As the swimmer climbs steadily up to the board, her ..... **1** ..... increases but her ..... **2** ..... remains constant.

When she dives off the board, her ..... **3** ..... increases. This is transferred mainly to ..... **4** ..... as she enters the water.

**SECTION B**Questions **THREE** and **FOUR**.In these questions choose the best **two** answers.Do **not** choose more than two.

Mark your choices on the answer sheet.

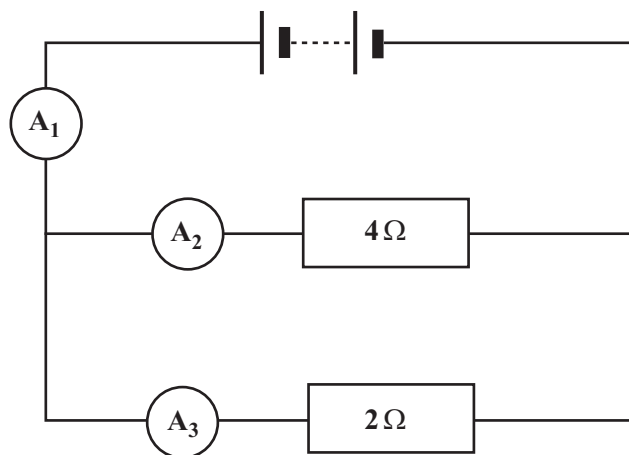
**QUESTION THREE**The circuit has three identical ammeters,  $A_1$ ,  $A_2$  and  $A_3$ .Which **two** statements, **J**, **K**, **L**, **M** or **N**, are correct?

- J** all the ammeters have the same reading
- K** the reading on ammeter  $A_3$  is greater than that on  $A_2$
- L** the reading on ammeter  $A_2$  is greater than that on  $A_3$
- M** the reading on ammeter  $A_2$  is identical to that on  $A_3$
- N** the reading on ammeter  $A_1$  is the sum of the readings on  $A_2$  and  $A_3$

Turn over ►



**QUESTION FOUR**

Thermal energy can be transferred by convection.

Which **two** of the following explain this method of energy transfer in a gas?

**cooler regions in the gas rise up through warmer regions**

**electrons gain kinetic energy when the gas is heated**

**gas particles are not involved in the transfer of thermal energy**

**gas particles move faster when the gas is heated**

**warm regions of gas are less dense than cooler regions**

**SECTION C**Questions **FIVE** to **TEN**.

Each of these questions has four parts.

In each part choose only **one** answer.

Mark your choices on the answer sheet.

**QUESTION FIVE**

The circuit shows a lamp of resistance 6 ohms, connected in series with a variable resistor **R**, a battery and a switch. When we set **R** to zero and close the switch, the current through the lamp is 2 A.

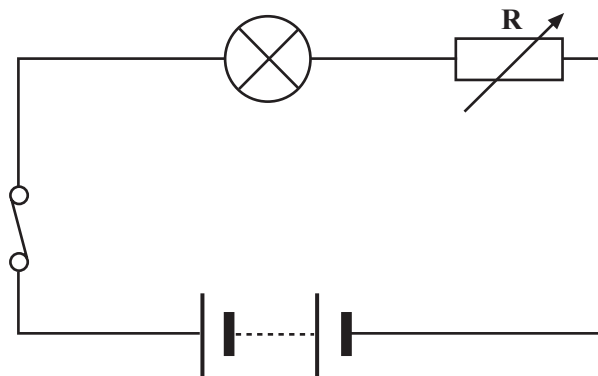

**5.1** What is the potential difference (voltage) across the battery?

- A** 0.33 V
- B** 3 V
- C** 12 V
- D** 24 V

**5.2** The battery is now changed to one of 10 V and **R** is increased from zero to exactly the same resistance as the lamp.

What will be the new potential difference (voltage) across the lamp?

- A** 5 V
- B** 6 V
- C** 10 V
- D** 20 V

5.3 **R** is now increased gradually from zero.

The resistance of the lamp will . . . . .

- A fall because the current in the lamp will be higher.
- B fall because the lamp will get cooler.
- C rise because the lamp will get hotter.
- D stay the same because the battery voltage is constant.

5.4 The circuit is now changed, so that the variable resistance **R** is in parallel with the lamp.

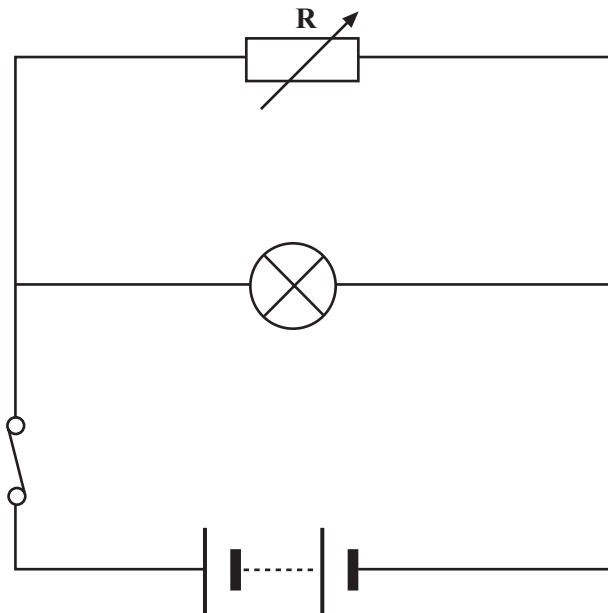

What will be the potential difference (voltage) across the lamp?

- A Double that across the battery
- B Half that across the battery
- C It depends on the value of **R**
- D The same as that across the battery

### QUESTION SIX

All the cells, lamps and diodes in these circuits are identical. Decide which lamps light in the different arrangements before you answer the questions.

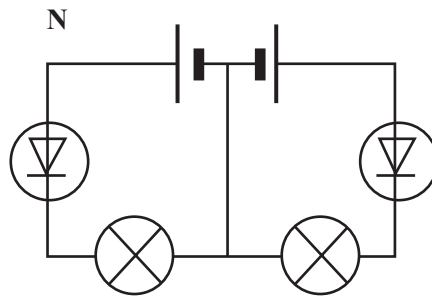
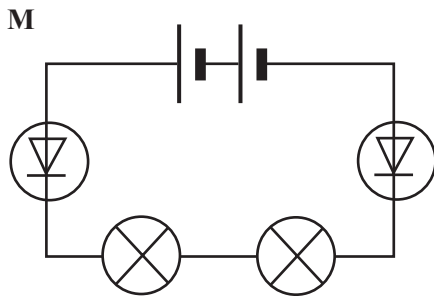
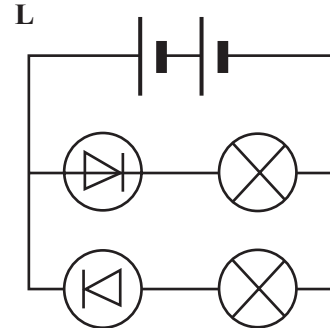
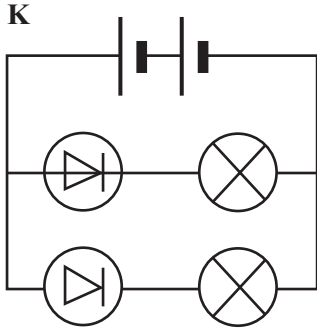

6.1 Neither lamp lights in . . . . .

- A circuit **K** only.
- B circuits **K**, **L** and **M**.
- C circuits **M** and **N**.
- D circuit **M** only.

6.2 Only one lamp lights in . . . . .

- A circuit **K** only.
- B circuits **K** and **M**.
- C circuits **L** and **N**.
- D circuit **L** only.

- 6.3** Both lamps light in . . . . .
- A** circuit **K** only.
  - B** circuits **K** and **N**.
  - C** circuits **L** and **M**.
  - D** circuit **M** only.
- 6.4** In which circuit do the cells run down most quickly?
- A** Circuit **K**
  - B** Circuit **L**
  - C** Circuit **M**
  - D** Circuit **N**

**TURN OVER FOR THE NEXT QUESTION**

---

**QUESTION SEVEN**

This question is about the energy resources used in power stations.

**7.1** The source of energy for geothermal power stations is . . . . .

- A** combustion.
- B** decay of radioactive elements.
- C** movement of air.
- D** movement of water.

**7.2** The gas mainly responsible for producing acid rain is . . . . .

- A** natural gas.
- B** nitrogen.
- C** oxygen.
- D** sulphur dioxide.

**7.3** What is the main advantage of a tidal barrage over a wind farm?

- A** More power is produced at times of high demand
- B** More power is produced in winter than in summer
- C** There are no environmental impacts
- D** The times and outputs for each day can be forecast

**7.4** 700 000 kilowatts of power are produced when 100 tonnes of coal are burned in 1 hour.

How quickly must the coal be burned to produce 7 000 000 kilowatts?

- A** 10 tonnes / hour
- B** 70 tonnes / hour
- C** 100 tonnes / hour
- D** 1000 tonnes / hour

**QUESTION EIGHT**

Mains electricity is usually an a.c. supply of about 230 V, frequency 50 Hz.

**8.1** Each of the oscilloscope traces shown corresponds to  $1/25$  of a second.

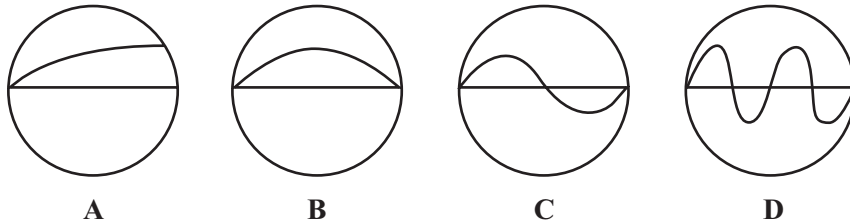

Which trace, **A**, **B**, **C** or **D**, shows the 50 Hz mains supply?

**8.2** The live and neutral mains wires carry the current.

Which statement is correct?

- A** The live and neutral voltages both alternate relative to earth
- B** The live wire has a positive voltage relative to earth
- C** The neutral wire has a voltage close to zero relative to earth
- D** The neutral wire has a voltage which is negative relative to earth

**8.3** Which is a correct reason why a.c. mains supplies are generally used?

- A** A safety fuse will operate with a.c. but not with d.c.
- B** The voltage can be changed easily, using transformers
- C** They are generally much safer than d.c. mains supplies
- D** They produce more energy than d.c. for the same voltage

**8.4** Why are a.c. supplies transmitted from power stations to local sub-stations at very high voltages?

- A** High voltage transmission is safer than low voltage transmission
- B** Local transformers can reduce the voltage to that needed by consumers
- C** Power stations produce electricity at very high voltages
- D** The higher the voltage, the less energy is wasted

**Turn over ►**

## QUESTION NINE

Solar panels transfer solar energy to heat water. This water then moves through a heat exchanger.

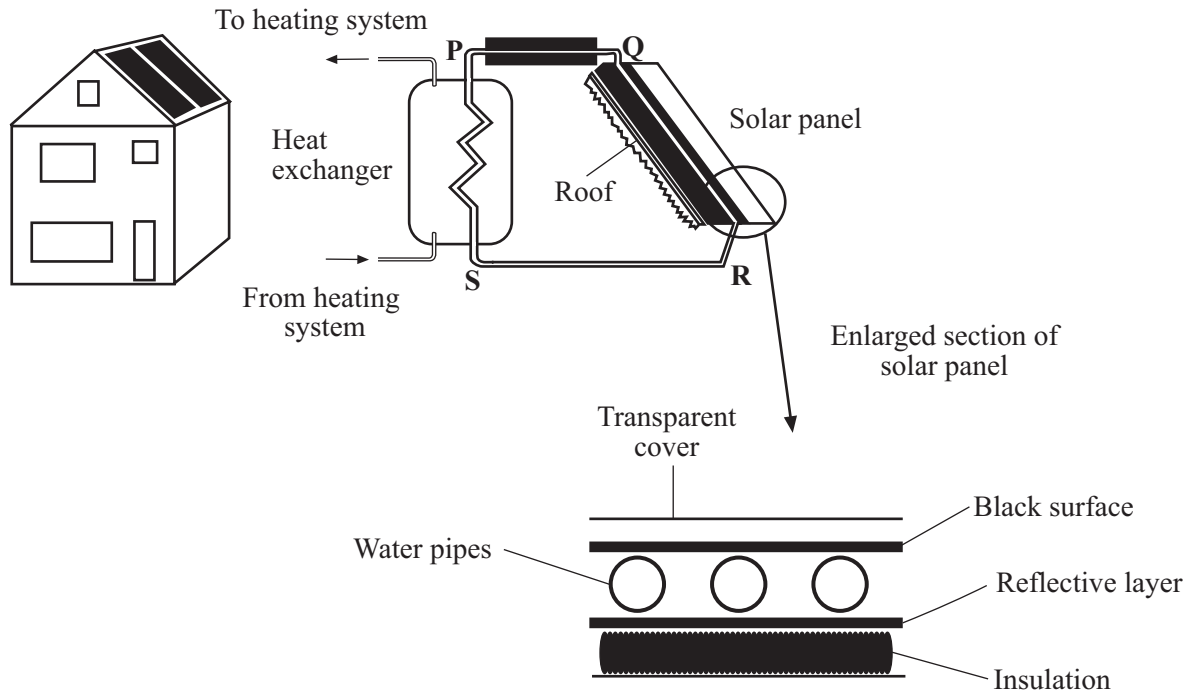

9.1 The different layers of the solar panel make the panel transfer solar energy in the most effective way.

Which row of the table, A, B, C or D, shows how each layer helps this?

	<b>Black top surface covering water pipes</b>	<b>Insulation</b>
<b>A</b>	absorbs radiant energy	stops heat conduction to roof
<b>B</b>	emits radiant energy	conducts heat to the water pipes
<b>C</b>	absorbs radiant energy	protects water pipes from frost
<b>D</b>	reflects radiant energy	conducts heat to roof space

9.2 When the system is operating . . . . .

- A** the water in tube **QR** becomes less dense and moves from **R** towards **Q**.
- B** the water in tube **QR** becomes more dense and moves from **Q** towards **R**.
- C** the water in tube **PS** becomes colder and moves from **S** towards **P**.
- D** the water in tube **PS** becomes warmer and moves from **S** towards **P**.



9.3 The water pipes are made of long narrow copper tubing laid on the underside of the black top surface.



This arrangement ensures that heat energy is . . . . .

- A conducted quickly to the water in the narrow tubing.
  - B distributed evenly between the top surface and the tubing.
  - C reflected from the top surface.
  - D transferred by convection.
- 9.4 Which design feature is most important for capturing maximum energy from the Sun's radiation?
- A Large surface area for the panel
  - B Short distance between the copper tubing loops
  - C Well insulated copper tubing
  - D Wide diameter for the copper tubing

**TURN OVER FOR THE NEXT QUESTION**

**Turn over ►**

---

**QUESTION TEN**

Senegal is a poor, developing country. It has no large power stations. Small, local schemes for generating power are used. Solar cells are used to generate electricity for pumping water from wells in remote locations.

**10.1** The main reason for using solar cells in such locations is that . . . . .

- A** low voltage from the solar cells is safer than high voltage power supplies.
- B** solar cells are cheap to make.
- C** solar cells provide a constant supply of electricity.
- D** the location is a long distance from other electricity supplies.

**10.2** Many solar cells are used in such locations because . . . . .

- A** the decommissioning costs are low.
- B** the energy supply is dilute.
- C** the installation costs are low.
- D** there will be less pollution.

An electrical pump is powered by the solar panels. It pumps 4 litres of water to a height of 10 metres in 30 seconds.

1 litre of water has a weight of 10 newtons.

**10.3** How much gravitational potential energy is gained by the water in 30 seconds?

- A** 13.3 J
- B** 40 J
- C** 400 J
- D** 12 000 J

**10.4**

You may find this equation useful when answering this part of the question.

$$\text{efficiency} = \frac{\text{useful energy transferred by device}}{\text{total energy supplied to device}}$$

On a different day, the water from the well gains 20 joules of energy per second.

3200 watts of solar energy fall on the solar cells.

What is the efficiency of the whole system?

- A** 0.006 25 (0.625%)
- B** 0.04 (4%)
- C** 0.062 5 (6.25%)
- D** 0.4 (40%)

**END OF TEST**