

Surname					Other Names				
Centre Number					Candidate Number				
Candidate Signature									

General Certificate of Secondary Education  
Spring 2003



**SCIENCE: SINGLE AWARD (MODULAR)  
Life and Living Processes (Module 13)**

**346013**

Wednesday 5 March 2003 Morning Session

**In addition to this paper you will require:**

- an HB pencil and a rubber;
- an answer sheet.

You may use a calculator.

Time allowed: 30 minutes

Copyright © 2003 AQA and its licensors. All rights reserved.

**Instructions**

- Fill in the boxes at the top of this page.
- Check that your name, candidate number and centre number are printed on the separate answer sheet.
- Check that the separate answer sheet has the title “Life and Living Processes” printed on it.
- Attempt **one Tier only, either** the Foundation Tier **or** the Higher Tier.
- Answer **all** the questions for the Tier you are attempting.
- Make sure that you use the correct side of the separate answer sheet; the Foundation Tier is printed on one side and the Higher Tier on the other.
- Mark your responses on the separate answer sheet only. Rough work may be done on the question paper.
- Mark the best responses by using a thick pencil stroke to fill in the box. Use an HB pencil. Make sure the pencil stroke does **not** extend beyond the box. Do **not** use ink or ball-point pen. If you wish to change your answer, rub out your first answer completely. See below.

**Examples:**

	1	2	3	4
	<input type="checkbox"/>	<input type="checkbox"/>	<input checked="" type="checkbox"/>	<input type="checkbox"/>
	<input type="checkbox"/>	<input checked="" type="checkbox"/>	<input type="checkbox"/>	<input type="checkbox"/>
	<input type="checkbox"/>	<input type="checkbox"/>	<input type="checkbox"/>	<input checked="" type="checkbox"/>
	<input checked="" type="checkbox"/>	<input type="checkbox"/>	<input type="checkbox"/>	<input type="checkbox"/>

<input checked="" type="checkbox"/>
<input type="checkbox"/>
<input type="checkbox"/>
<input checked="" type="checkbox"/>
<input type="checkbox"/>

QUESTION XXX				
xxx.1	<input type="checkbox"/> A	<input checked="" type="checkbox"/> B	<input type="checkbox"/> C	<input type="checkbox"/> D
xxx.2	<input type="checkbox"/> A	<input type="checkbox"/> B	<input type="checkbox"/> C	<input checked="" type="checkbox"/> D
xxx.3	<input type="checkbox"/> A	<input checked="" type="checkbox"/> B	<input type="checkbox"/> C	<input type="checkbox"/> D
xxx.4	<input checked="" type="checkbox"/> A	<input type="checkbox"/> B	<input type="checkbox"/> C	<input type="checkbox"/> D

**Information**

- The maximum mark for this paper is 36.

**Advice**

- Do **not** choose more responses than you are asked to. You will lose marks if you do.
- Make sure that you hand in both your answer sheet and this question paper at the end of the test.
- If you start to answer on the wrong side of the answer sheet by mistake, make sure that you rub out **completely** the work that is not to be marked.

---

You must do **one Tier** only, **either** the Foundation Tier **or** the Higher Tier.  
The Higher Tier starts on page 12 of this booklet.

---

**FOUNDATION TIER**

**SECTION A**

Questions **ONE** to **FIVE**.

In these questions match the words in the list with the numbers.

Use **each** answer only **once**.

Mark your choices on the answer sheet.

---

**QUESTION ONE**

The diagram shows part of the digestive system.

Match words from the list with each of the labels **1–4** on the diagram.

**makes bile**

**makes lipase**

**provides acid conditions**

**stores bile**

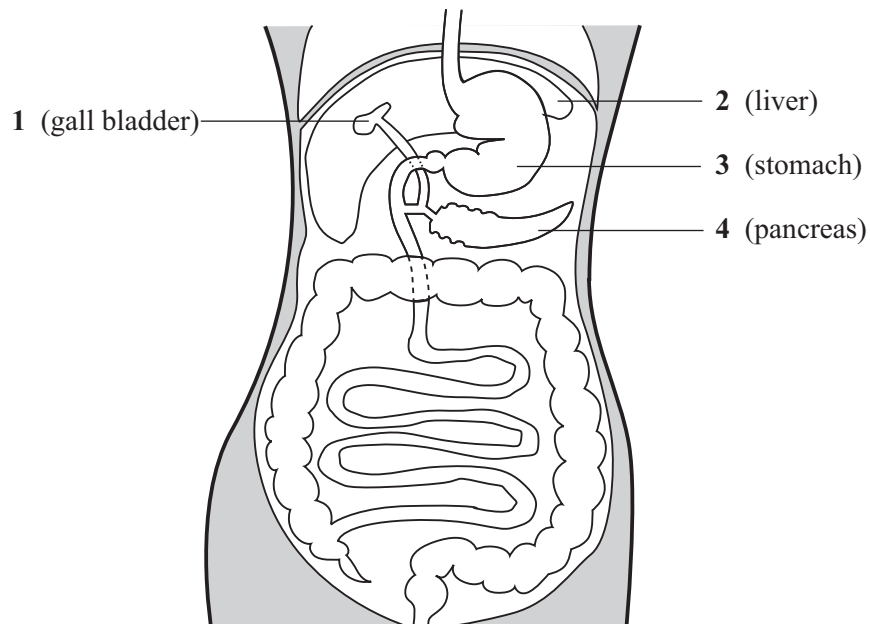

**QUESTION TWO**

The drawing shows a deer.

The deer has organs which contain different receptors.

Match words from the list with each of the labels 1–4 in the drawing.

**contains light receptors**

**contains movement receptors**

**contains receptors sensitive to chemicals**

**contains temperature receptors**

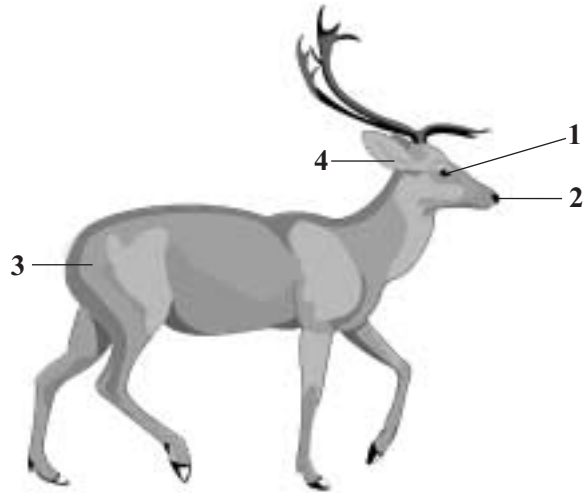
**QUESTION THREE**

The table is about substances that help the body to defend itself against microorganisms.

Match words from the list with each of the numbers 1–4 in the table.

**antibody**

**antitoxin**

**blood clot**

**mucus**

Substance	Feature
1	kills microorganisms
2	neutralises poisons produced by microorganisms
3	seals cuts to prevent entry of microorganisms
4	traps microorganisms

**Turn over ►**

**QUESTION FOUR**

The diagram shows a nerve cell. This cell passes information to other cells.

Match words from the list with each of the labels 1–4 on the diagram.

**cell membrane**

**controls the activities of the cell**

**cytoplasm**

**passes information to other cells**

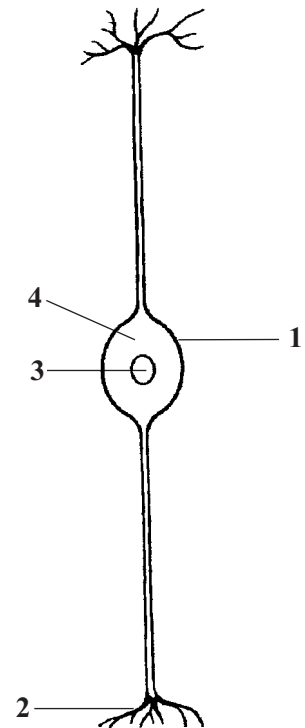
**QUESTION FIVE**

The diagram shows some parts of the blood as seen through a microscope.

Match words from the list with each of the labels 1–4 on the diagram.

**clots blood**

**ingests microorganisms**

**transports oxygen**

**transports urea**

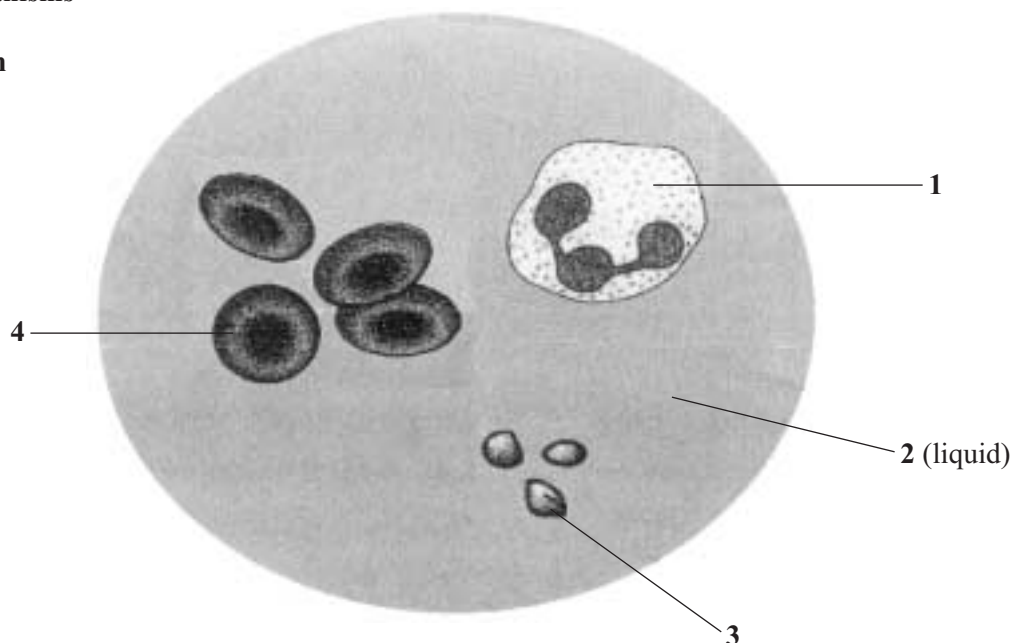

---

**SECTION B**Questions **SIX** and **SEVEN**.In these questions choose the best **two** answers.Do **not** choose more than two.Mark your choices on the answer sheet.

---

**QUESTION SIX**

All living organisms produce waste materials.

Which **two** of the following are waste substances produced by humans?**amino acid****carbon dioxide****carbon monoxide****hormone****urea****QUESTION SEVEN**

Bacteria and viruses both cause diseases.

Which **two** of the following are true of bacteria and viruses?**they are both microorganisms****they both contain cytoplasm****they both contain genes****they both have a nucleus****they both have a protein coat****Turn over ►**

---

**SECTION C**Questions **EIGHT** to **TEN**.

Each of these questions has four parts.

In each part choose only **one** answer.Mark your choices on the answer sheet.

---

**QUESTION EIGHT**

The diagram shows a section through an eye.

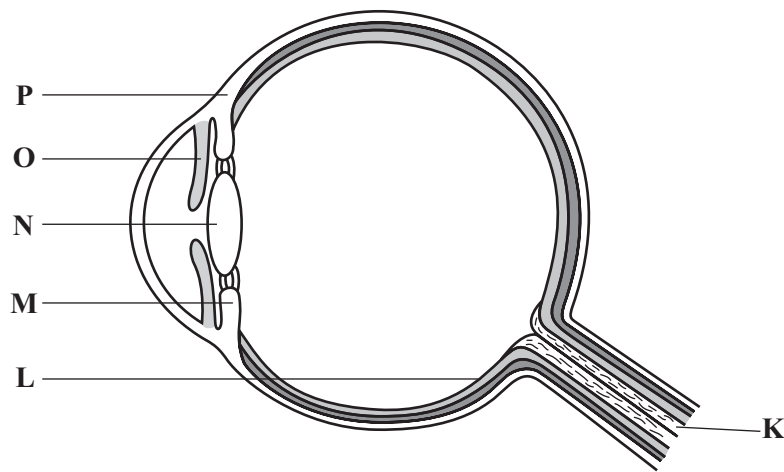
**8.1** Which part of the eye is tough and white in colour?

- A** M
- B** N
- C** O
- D** P

**8.2** The function of part **L** is to . . . . .

- A** control the amount of light entering the eye.
- B** focus light.
- C** form electrical impulses.
- D** protect the eyeball.

**8.3** Which of the following parts hold the lens in place?

- A** Ciliary muscles and iris
- B** Iris and sclera
- C** Sclera and suspensory ligaments
- D** Suspensory ligaments and ciliary muscles

**8.4** Which of the following parts are made of muscle?

- A** **K** and **L**
- B** **L** and **M**
- C** **M** and **O**
- D** **O** and **P**

**TURN OVER FOR THE NEXT QUESTION**

**Turn over ►**

**QUESTION NINE**

The information is from a box containing breakfast cereal.

	<b>Amount per 100 g</b>
Energy	1800 kJ
Protein	6 g
Carbohydrate	83 g
Fat	3 g

**9.1** The recommended daily intake of energy for a young adult male is 12 000 kJ.

A 40 g serving of cereal will provide . . . . .

- A  $\frac{3}{100}$  (3%) of the daily requirement for energy.
- B  $\frac{6}{100}$  (6%) of the daily requirement for energy.
- C  $\frac{15}{100}$  (15%) of the daily requirement for energy.
- D  $\frac{3}{10}$  (30%) of the daily requirement for energy.

**9.2** The amount of protein that a young adult female needs each day is 60 g.

How much cereal would the female have to eat to get this amount of protein?

- A 10 g
- B 100 g
- C 500 g
- D 1000 g

**9.3** During digestion the starch in the cereal will be broken down into . . . . .

- A amino acids.
- B fatty acids.
- C glycerol.
- D sugars.



- 9.4** Starch digesting enzymes are produced in the . . . . .
- A** pancreas and small intestine.
  - B** salivary glands only.
  - C** salivary glands, pancreas and small intestine.
  - D** small intestine only.

**TURN OVER FOR THE NEXT QUESTION**

**QUESTION TEN**

A man had some alcoholic drink at home. Later he went out and had some more alcoholic drink.

The graph shows the concentration of alcohol in the man's blood over this period and the next few hours.

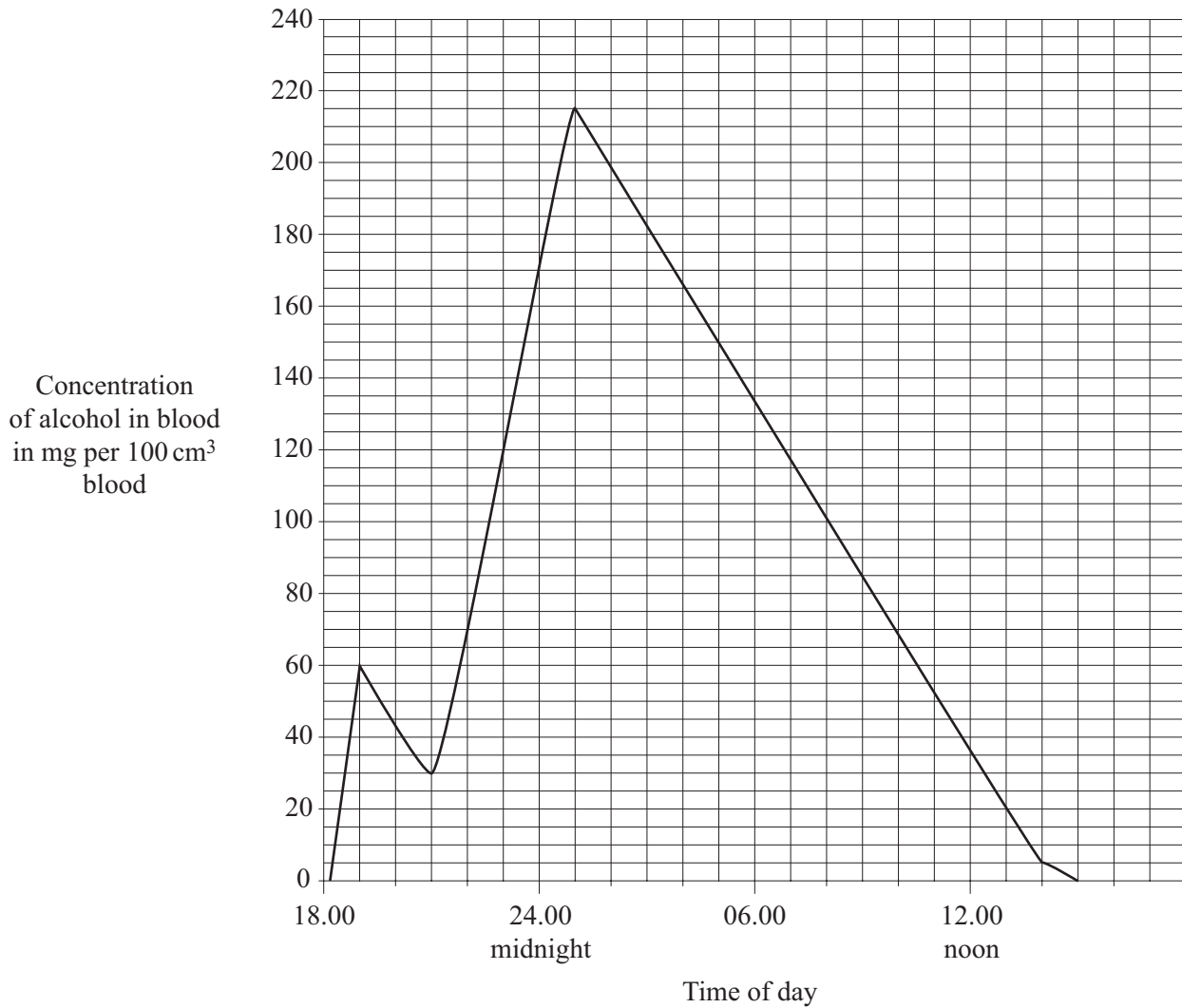

**10.1** What was the highest concentration of alcohol in the man's blood?

- A 205 mg per 100 cm<sup>3</sup>
- B 208 mg per 100 cm<sup>3</sup>
- C 215 mg per 100 cm<sup>3</sup>
- D 218 mg per 100 cm<sup>3</sup>

**10.2** The legal limit for driving in Britain is 80 mg alcohol per 100 cm<sup>3</sup> of blood.

During which of the following periods would it be illegal for the man to drive?

- A** 18.30 to 14.45
- B** 19.00 to 01.00
- C** 21.00 to 01.00
- D** 22.15 to 09.15

**10.3** It is dangerous to drive a car after drinking alcohol because . . . . .

- A** alcohol is addictive.
- B** alcohol can cause lung cancer.
- C** alcohol damages the liver.
- D** alcohol slows reactions.

**10.4** Which one of the following is **not** usually caused by smoking tobacco?

- A** Brain damage
- B** Bronchitis
- C** Emphysema
- D** Heart disease

**END OF TEST**

---

You must do **one Tier** only, **either** the Foundation Tier **or** the Higher Tier.  
The Foundation Tier is earlier in this booklet.

---

**HIGHER TIER**

**SECTION A**

Questions **ONE** and **TWO**.

In these questions match the words in the list with the numbers.

Use **each** answer only **once**.

Mark your choices on the answer sheet.

---

**QUESTION ONE**

The diagram shows some parts of the blood as seen through a microscope.

Match words from the list with each of the labels **1–4** on the diagram.

**clots blood**

**ingests microorganisms**

**transports oxygen**

**transports urea**

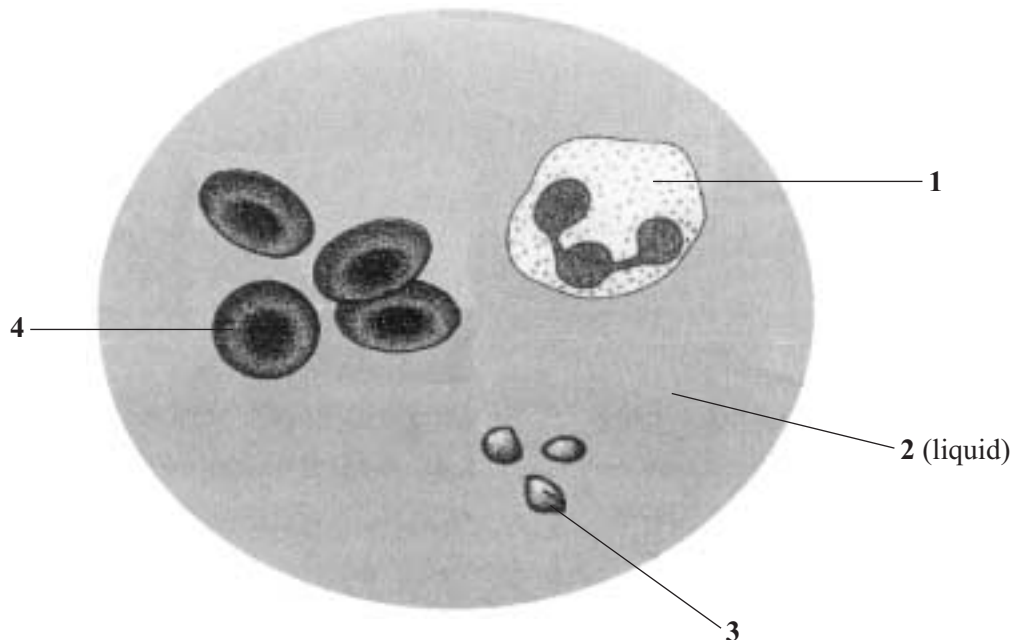

---

**QUESTION TWO**

The eye can see near and distant objects.

Match words from the list with each of the numbers **1–4** in the sentences.

**change shape**

**focus**

**relax**

**tighten**

When you want to see a distant object clearly, your eye must ..... **1** .....

To do this, the ciliary muscles ..... **2** .....

This makes the suspensory ligaments ..... **3** ..... causing the lens to ..... **4** .....

**TURN OVER FOR THE NEXT QUESTION**

**Turn over ▶**

---

**SECTION B**Questions **THREE** and **FOUR**.In these questions choose the best **two** answers.Do **not** choose more than two.Mark your choices on the answer sheet.

---

**QUESTION THREE**

Bacteria and viruses both cause diseases.

Which **two** of the following are true of bacteria and viruses?**they are both microorganisms****they both contain cytoplasm****they both contain genes****they both have a nucleus****they both have a protein coat****QUESTION FOUR**

Substances are filtered from the blood by the kidneys.

Which **two** of the following substances are reabsorbed by the kidneys?**ADH****dissolved ions****insulin****sugars****urea**

---

**SECTION C**Questions **FIVE** to **TEN**.

Each of these questions has four parts.

In each part choose only **one** answer.Mark your choices on the answer sheet.

---

**QUESTION FIVE**

The diagram shows a section through an eye.

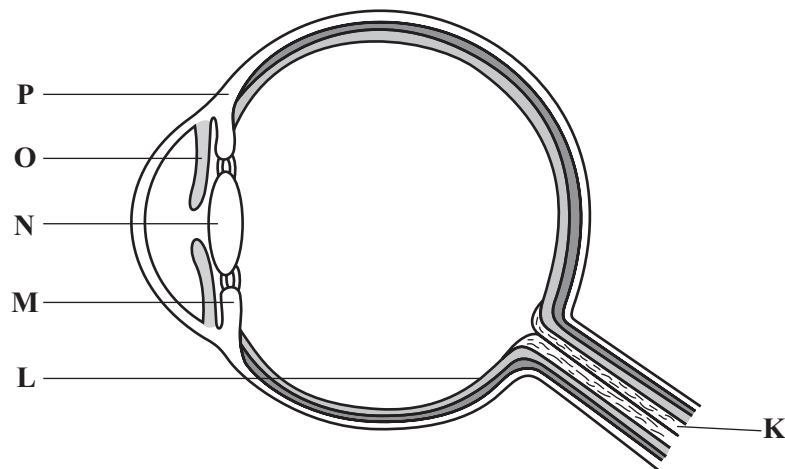
**5.1** Which part of the eye is tough and white in colour?

- A** M
- B** N
- C** O
- D** P

**5.2** The function of part **L** is to . . . . .

- A** control the amount of light entering the eye.
- B** focus light.
- C** form electrical impulses.
- D** protect the eyeball.

**5.3** Which of the following parts hold the lens in place?

- A** Ciliary muscles and iris
- B** Iris and sclera
- C** Sclera and suspensory ligaments
- D** Suspensory ligaments and ciliary muscles

**5.4** Which of the following parts are made of muscle?

- A** **K** and **L**
- B** **L** and **M**
- C** **M** and **O**
- D** **O** and **P**

**TURN OVER FOR THE NEXT QUESTION**

**Turn over ►**



**QUESTION SIX**

The information is from a box containing breakfast cereal.

	<b>Amount per 100 g</b>
Energy	1800 kJ
Protein	6 g
Carbohydrate	83 g
Fat	3 g

**6.1** The recommended daily intake of energy for a young adult male is 12 000 kJ.

A 40 g serving of cereal will provide . . . . .

- A  $\frac{3}{100}$  (3%) of the daily requirement for energy.
- B  $\frac{6}{100}$  (6%) of the daily requirement for energy.
- C  $\frac{15}{100}$  (15%) of the daily requirement for energy.
- D  $\frac{3}{10}$  (30%) of the daily requirement for energy.

**6.2** The amount of protein that a young adult female needs each day is 60 g.

How much cereal would the female have to eat to get this amount of protein?

- A 10 g
- B 100 g
- C 500 g
- D 1000 g

**6.3** During digestion the starch in the cereal will be broken down into . . . . .

- A amino acids.
- B fatty acids.
- C glycerol.
- D sugars.

- 6.4** Starch digesting enzymes are produced in the . . . . .
- A** pancreas and small intestine.
  - B** salivary glands only.
  - C** salivary glands, pancreas and small intestine.
  - D** small intestine only.

**TURN OVER FOR THE NEXT QUESTION**

**QUESTION SEVEN**

A man had some alcoholic drink at home. Later he went out and had some more alcoholic drink.

The graph shows the concentration of alcohol in the man's blood over this period and the next few hours.

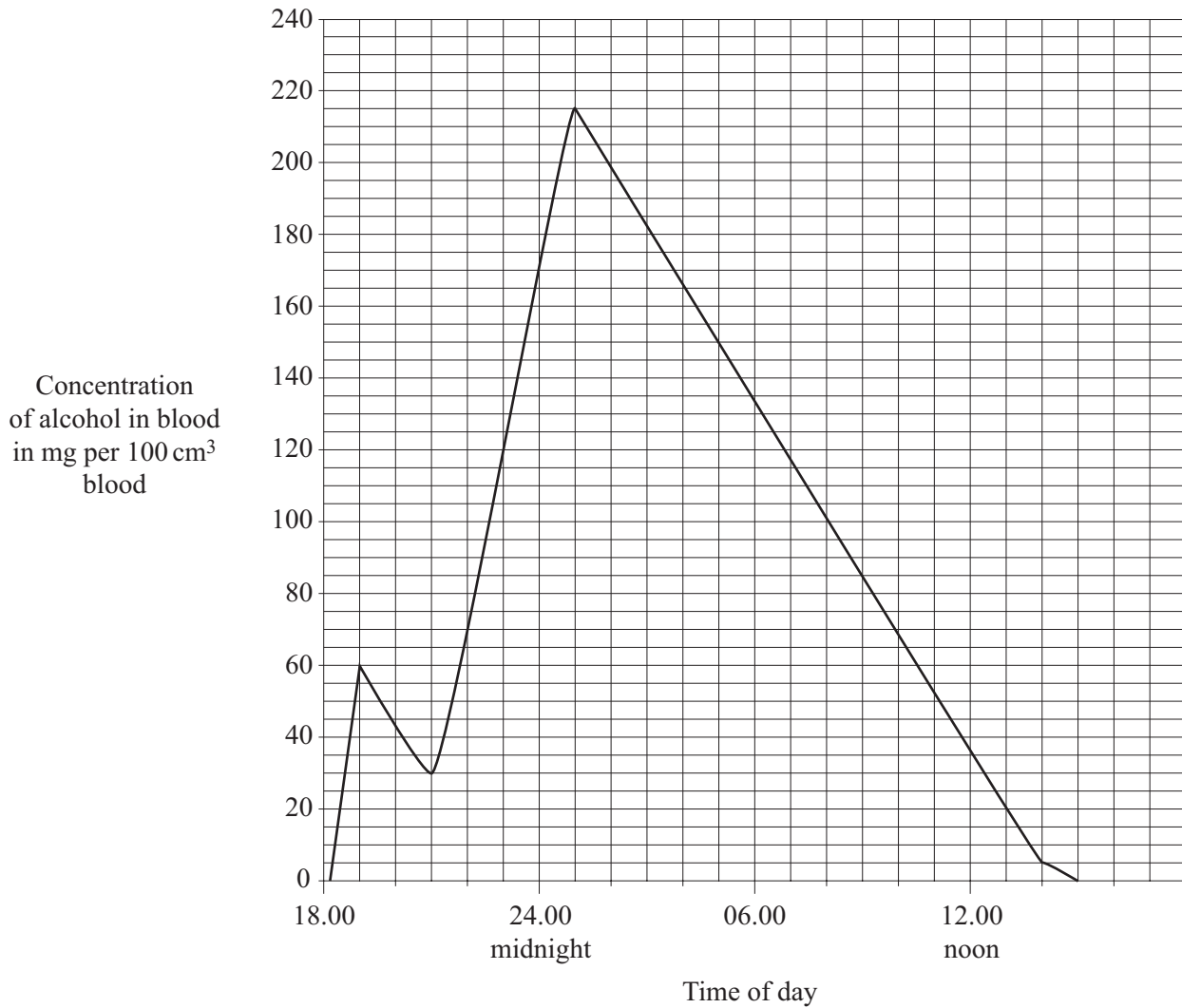

7.1 What was the highest concentration of alcohol in the man's blood?

- A 205 mg per 100 cm<sup>3</sup>
- B 208 mg per 100 cm<sup>3</sup>
- C 215 mg per 100 cm<sup>3</sup>
- D 218 mg per 100 cm<sup>3</sup>

7.2 The legal limit for driving in Britain is 80 mg alcohol per 100 cm<sup>3</sup> of blood.

During which of the following periods would it be illegal for the man to drive?

- A 18.30 to 14.45
- B 19.00 to 01.00
- C 21.00 to 01.00
- D 22.15 to 09.15

7.3 It is dangerous to drive a car after drinking alcohol because . . . . .

- A alcohol is addictive.
- B alcohol can cause lung cancer.
- C alcohol damages the liver.
- D alcohol slows reactions.

7.4 Which one of the following is **not** usually caused by smoking tobacco?

- A Brain damage
- B Bronchitis
- C Emphysema
- D Heart disease

**TURN OVER FOR THE NEXT QUESTION**

**Turn over ►**

**QUESTION EIGHT**

Protease enzymes digest boiled egg white.

A student carried out an investigation using proteases from two different regions, **P** and **R**, of the human digestive system.

The results of this investigation are shown in the table.

Region of human digestive system	Time taken for egg white to be digested (minutes)		
	in ACID conditions	in NEUTRAL conditions	in ALKALINE conditions
<b>P</b>	20	Egg white not digested after 120 minutes	Egg white not digested after 120 minutes
<b>R</b>	Egg white not digested after 120 minutes	80	40

**8.1** Enzyme **R** . . . . .

- A** works faster in neutral conditions than in alkaline conditions.
- B** works half as fast in alkaline conditions than enzyme **P** does in acid conditions.
- C** works ten times faster in alkaline conditions than enzyme **P** does in acid conditions.
- D** works twice as fast in alkaline conditions than enzyme **P** does in acid conditions.

**8.2** Enzymes **P** and **R** are from different regions of the digestive system.

Which of the following are the most likely sites of enzymes **P** and **R**?

- A** Enzyme **P** is found in the gullet and enzyme **R** in the large intestine
- B** Enzyme **P** is found in the mouth and enzyme **R** in the stomach
- C** Enzyme **P** is found in the stomach and enzyme **R** in the large intestine
- D** Enzyme **P** is found in the stomach and enzyme **R** in the small intestine

**8.3** The conditions in which enzyme **R** works best are provided by . . . . .

- A** bile.
- B** hydrochloric acid.
- C** mucus.
- D** saliva.

**8.4** A patient has a blockage in the tube leading from the gall bladder to the small intestine.

The most likely effect of this is that . . . . .

- A** active transport of amino acids is slowed down.
- B** digestion of fats is slowed down.
- C** less faeces are produced.
- D** less water is absorbed.

**TURN OVER FOR THE NEXT QUESTION**

**Turn over ►**

### QUESTION NINE

If dust gets into our eye, we blink. The diagram represents this reflex action.

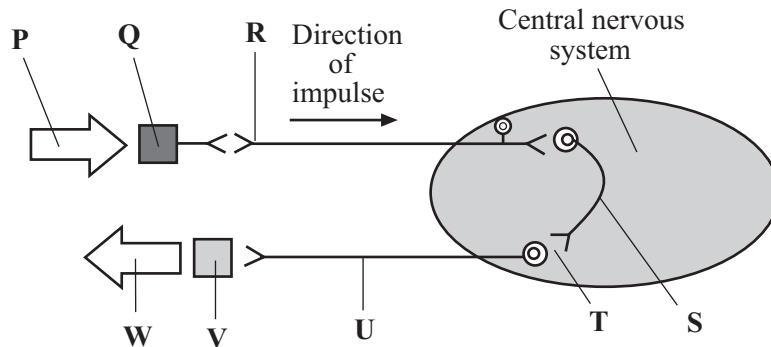

9.1 Which part of the diagram represents the effector in this reflex action?

- A P
- B Q
- C V
- D W

9.2 Which part of the diagram represents a relay neurone?

- A R
- B S
- C U
- D V

9.3 Part T on the diagram represents . . . . .

- A the brain.
- B a nerve.
- C the spinal cord.
- D a synapse.

**9.4** The effectors in this response are . . . . .

- A** capillaries.
- B** glands.
- C** hormones.
- D** muscles.

**TURN OVER FOR THE NEXT QUESTION**



**QUESTION TEN**

The graph shows the effect of a 10 minute exercise period on the core body temperature of an athlete.

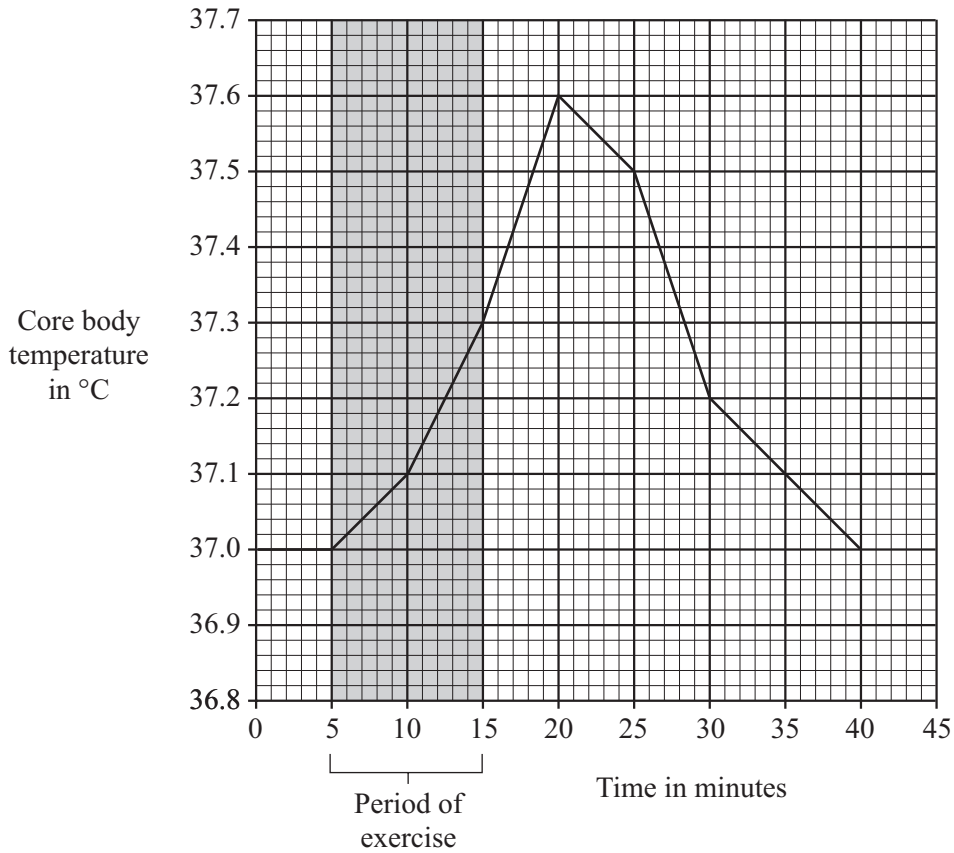

**10.1** By how much did the core body temperature continue to rise after the end of the exercise period?

- A 0.3  $^{\circ}\text{C}$
- B 0.6  $^{\circ}\text{C}$
- C 5.0  $^{\circ}\text{C}$
- D 37.6  $^{\circ}\text{C}$

**10.2** What was the average rate of fall in body temperature between 20 and 35 minutes?

- A 0.008  $^{\circ}\text{C}$  per minute
- B 0.033  $^{\circ}\text{C}$  per minute
- C 0.1  $^{\circ}\text{C}$  per minute
- D 0.5  $^{\circ}\text{C}$  per minute

- 10.3** When the core body temperature increases, the athlete is likely to . . . . .
- A** release less sweat and the blood vessels supplying his skin capillaries will constrict.
  - B** release less sweat and the blood vessels supplying his skin capillaries will dilate.
  - C** release more sweat and the blood vessels supplying his skin capillaries will constrict.
  - D** release more sweat and the blood vessels supplying his skin capillaries will dilate.
- 10.4** Body temperature is kept at about 37°C because . . . . .
- A** enzymes work best at this temperature.
  - B** it provides enough energy for sweating to occur.
  - C** muscles contract more powerfully when warm.
  - D** the body needs to be as hot as possible.

**END OF TEST**