

Surname		Other Names	
Centre Number		Candidate Number	
Candidate Signature			

Leave blank

General Certificate of Secondary Education
June 2005



**SCIENCE: DOUBLE AWARD (CO-ORDINATED) 3462/3F
FOUNDATION TIER
Paper 3**

Wednesday 22 June 2005 9.00 am to 10.30 am

F

In addition to this paper you will require:
a ruler.
You may use a calculator.

For Examiner's Use			
Number	Mark	Number	Mark
1		9	
2		10	
3		11	
4		12	
5		13	
6			
7			
8			
Total (Column 1)	→		
Total (Column 2)	→		
TOTAL			
Examiner's Initials			

Time allowed: 1 hour 30 minutes

Instructions

- Use blue or black ink or ball-point pen.
- Fill in the boxes at the top of this page.
- Answer **all** questions in the spaces provided.
- Do all rough work in this book. Cross through any work you do not want marked.

Information

- The maximum mark for this paper is 90.
- Mark allocations are shown in brackets.
- You are reminded of the need for good English and clear presentation in your answers.

1 The diagram shows two satellites orbiting the Earth.

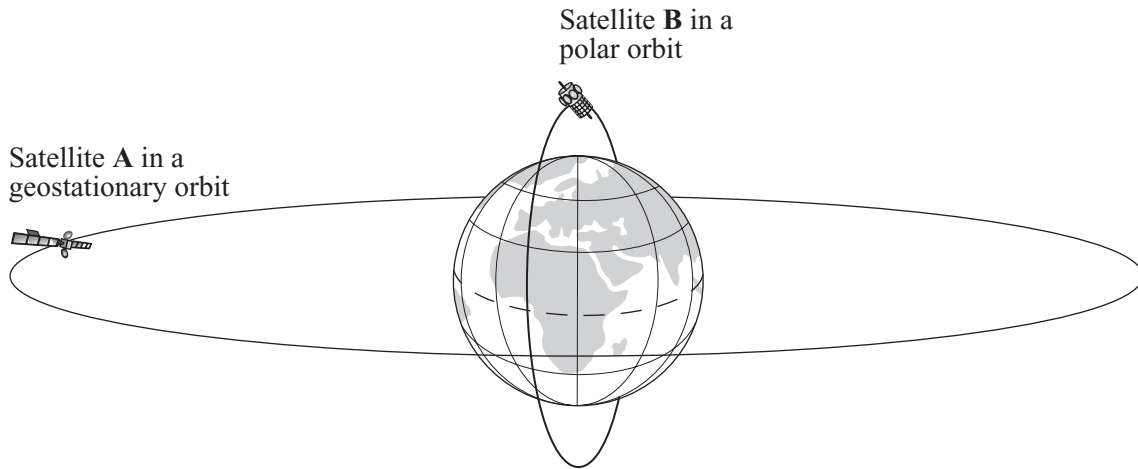

The two satellites have the same mass.

(a) Complete the following sentences by crossing out the **two** lines in each box that are wrong.

(i) The time for one orbit by satellite **B** is less than
the same as
more than the time for one orbit by satellite **A**. (1 mark)

(ii) The force of attraction between the Earth and satellite **B** is less than
the same as
more than the force of attraction between the Earth and satellite **A**. (1 mark)

(b) A communication satellite is put into a *geostationary* orbit.

Describe a *geostationary* orbit.

.....

.....

.....

.....

(2 marks)

2 (a) The diagram shows an object in orbit around the Sun.

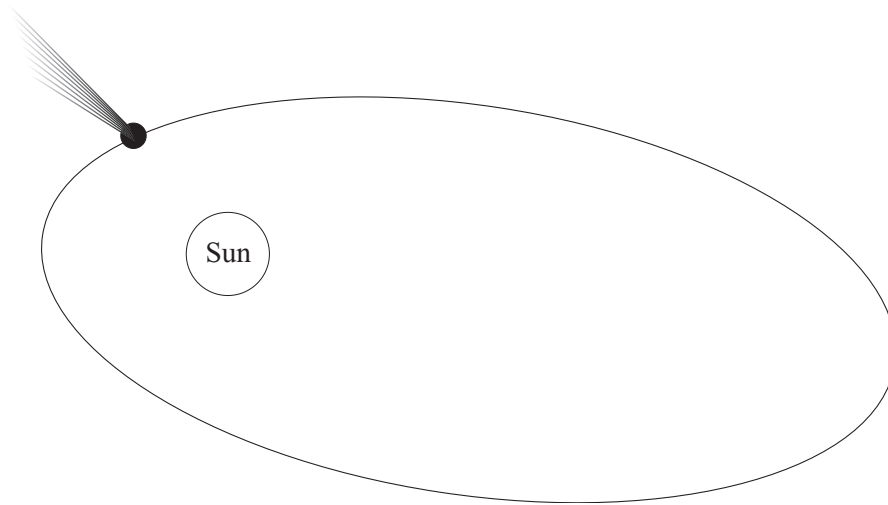

Which **one** of the following is the object most likely to be?

Draw a ring around your answer.

- comet moon planet star**

(1 mark)

(b) The Sun is part of the Milky Way galaxy.
What is a galaxy?

.....
(1 mark)

(c) Complete the following sentence by choosing the correct words from the box.
Each word may be used once or not at all.

dwarf	giant	neutron	proton	supernova
--------------	--------------	----------------	---------------	------------------

If a red star is large enough, it may eventually blow up in an explosion called a, leaving behind a very dense star.

(3 marks)

5

Turn over ►

3 The diagram shows the types of wave that make up the electromagnetic spectrum.

gamma rays	X-rays	ultraviolet	light	infra red	microwaves	radio
------------	--------	-------------	-------	-----------	------------	-------

(a) Which type of wave:

(i) has the longest wavelength and lowest frequency;

.....
(1 mark)

(ii) can be used to kill harmful bacteria in food;

.....
(1 mark)

(iii) is used in sunbeds to give a sun-tan;

.....
(1 mark)

(iv) is used to send information between mobile phones?

.....
(1 mark)

(b) Complete the following sentence by crossing out the **two** lines in the box that are wrong.

The speed of light rays through space is

faster than
the same as
slower than

 the speed of radio waves through space.
(1 mark)

(c) The picture shows a horse being prepared for an X-ray.

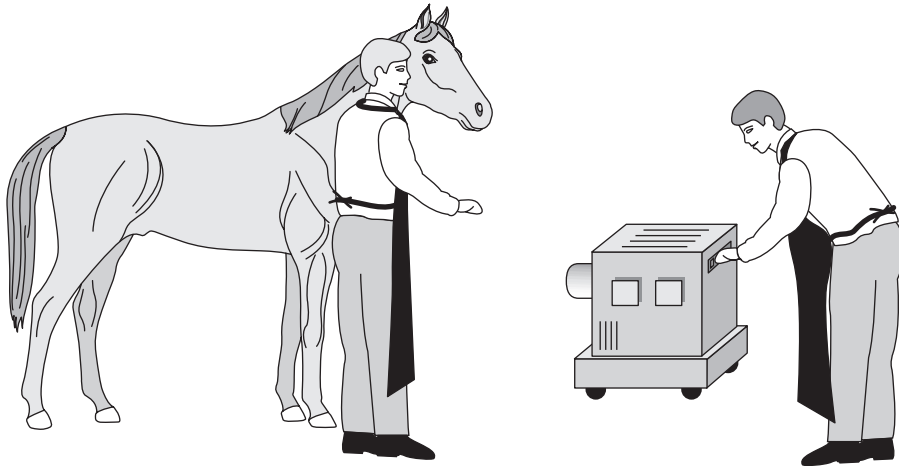

The person who will take the X-ray and the person holding the horse are wearing special aprons. These aprons have a lead lining.

Explain why the lead lining is important.

To gain full marks in this question you should write your ideas in good English. Put them into a sensible order and use the correct scientific words.

.....

.....

.....

.....

.....

.....

(3 marks)

8

TURN OVER FOR THE NEXT QUESTION

Turn over ►

- 4 A castle is a long way from the nearest town. Batteries power the car park ticket machine. Solar cells are used to keep the batteries charged.

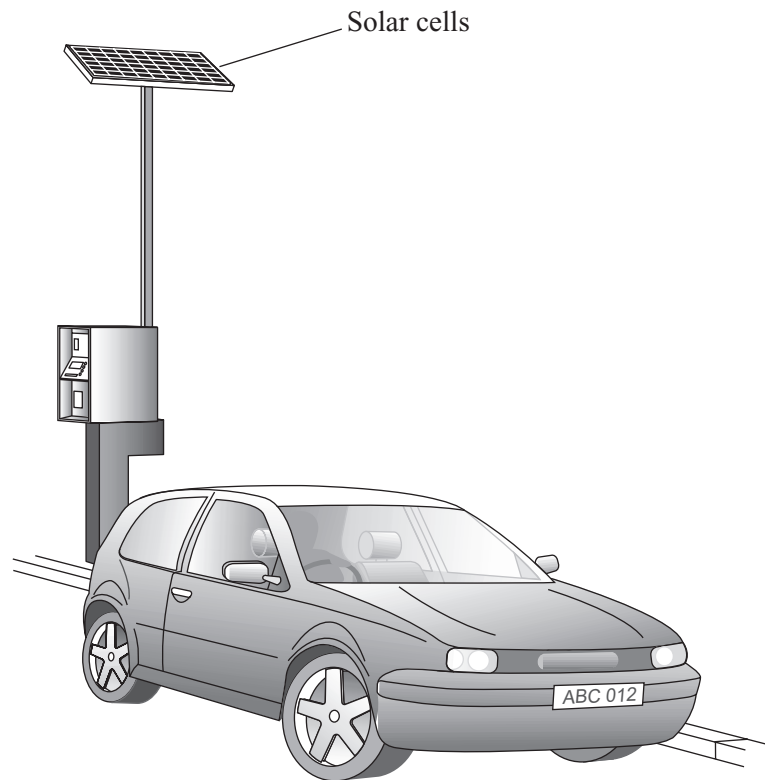

- (a) Complete the following sentences by choosing the correct words from the box.

Each word may be used once or not at all.

chemical	electrical	heat	light	sound
-----------------	-------------------	-------------	--------------	--------------

- (i) The energy input to the solar cells is energy. *(1 mark)*
- (ii) The useful energy output from the solar cells is energy. *(1 mark)*

- (b) For every 500 J of energy absorbed by the solar cells, 75 J of energy are transferred to the batteries.

Use the following equation to calculate the efficiency of the solar cells.
Show clearly how you work out your answer.

$$\text{Efficiency} = \frac{\text{useful energy transferred by device}}{\text{total energy supplied to device}}$$

.....
.....

Efficiency =
(2 marks)

- (c) Which **one** of the following statements gives the main reason for using solar cells to charge the batteries?

Tick (✓) the box next to your choice.

Solar cells give a constant supply of electricity.

A few solar cells can provide a large amount of electricity.

The ticket machine is a long way from other electricity supplies.

(1 mark)

- (d) The graph shows how the cost of producing electricity using solar cells has changed.

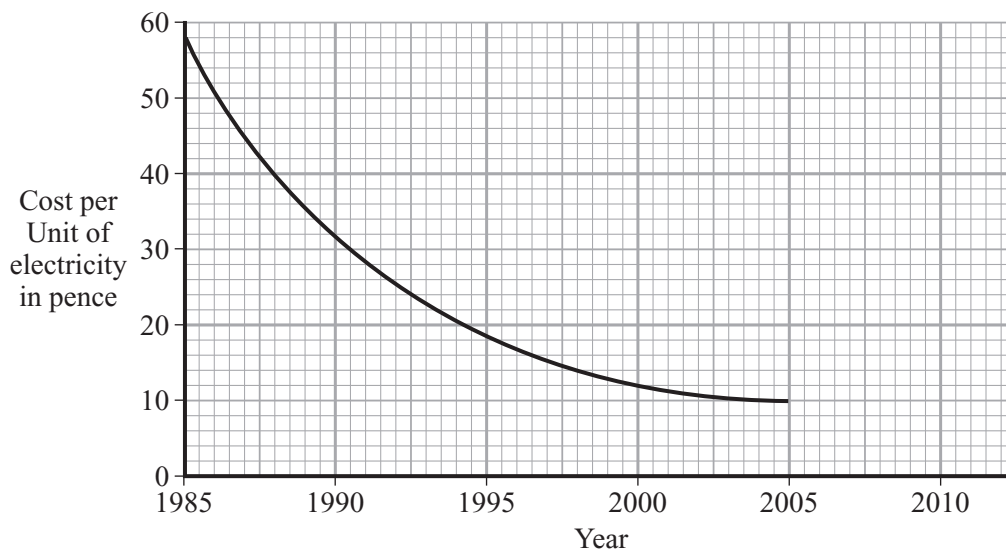

Use the graph to predict the cost of one Unit of electricity in 2010.

.....
(1 mark)

Turn over ►

- 5 (a) Radiation is around us all of the time. The pie chart shows the sources of this radiation.

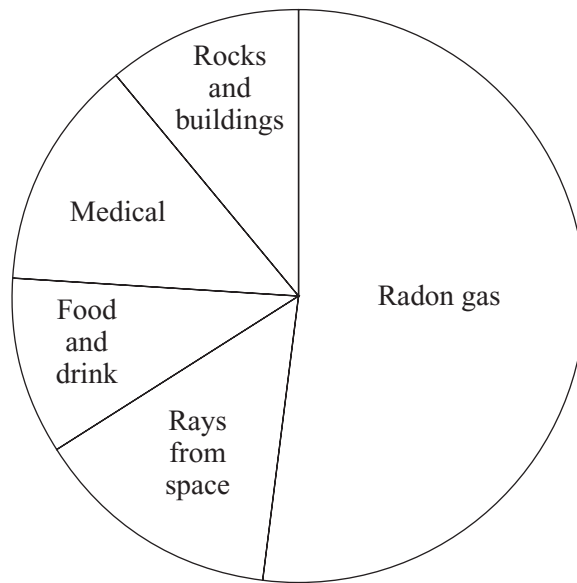

- (i) What is the main source of this radiation?

.....
(1 mark)

- (ii) What name is given to the radiation that is around us all of the time?

.....
(1 mark)

- (b) Radiation can cause cancer. The graph shows that the risk of cancer depends on the radiation dose a person is exposed to.

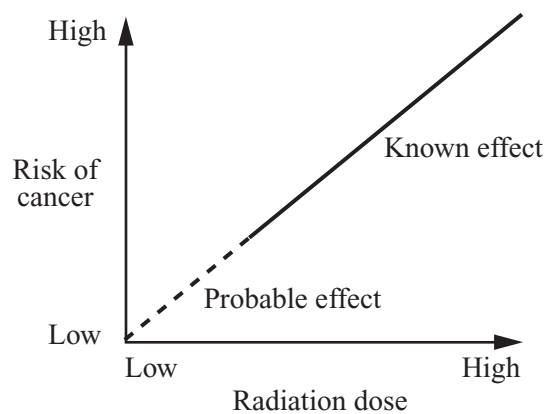

Complete the following sentence.

The the dose of radiation a person gets, the greater the risk of cancer.
(1 mark)

- (c) A worker in a nuclear power station wears a special badge (diagram 1). Diagram 2 shows what is inside the badge. When the film inside the badge is developed, it will be dark in the places where it has absorbed radiation.

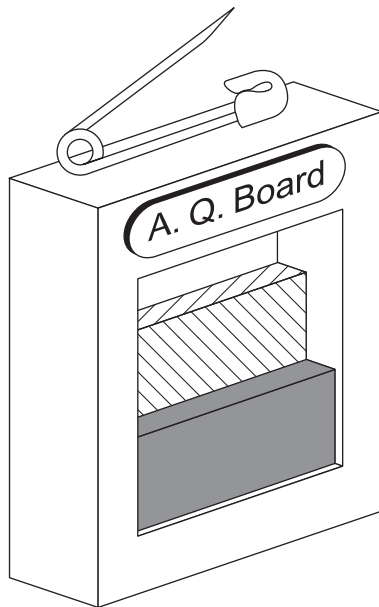

Diagram 1

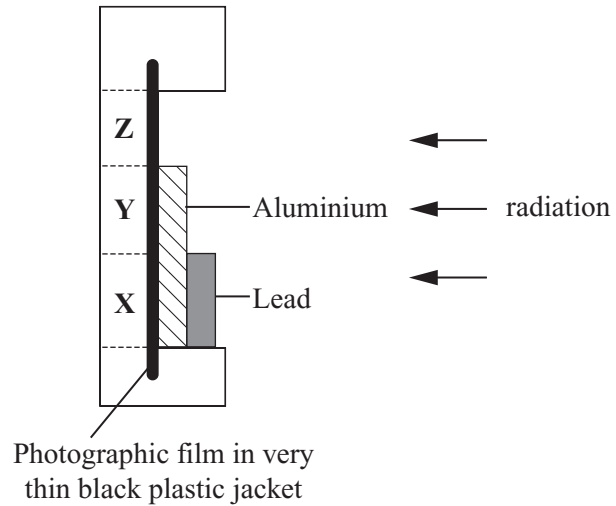

Diagram 2

Which part of the film, X, Y or Z, would darken if the worker had received a dose of alpha radiation?

.....

Give a reason for your answer.

.....

.....

(2 marks)

5

TURN OVER FOR THE NEXT QUESTION

Turn over ►

- 6 (a) Combing dry hair with a plastic comb makes the comb become positively charged.



Why does the comb become positively charged?

.....

.....

(1 mark)

- (b) Two objects are drawn in each of the boxes **A**, **B** and **C**. Each object is positively charged, negatively charged or uncharged.

Write under each box whether the two objects will:

repel each other;

attract each other;

do nothing.

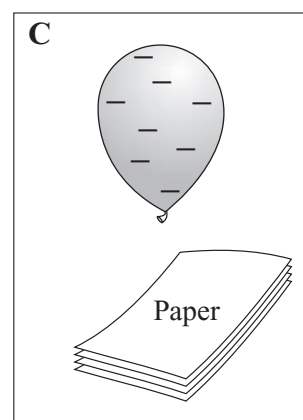
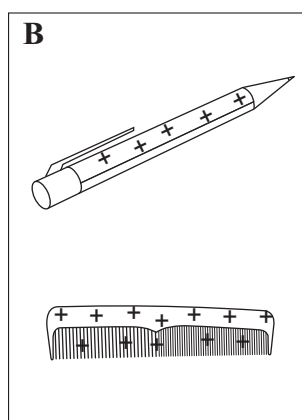
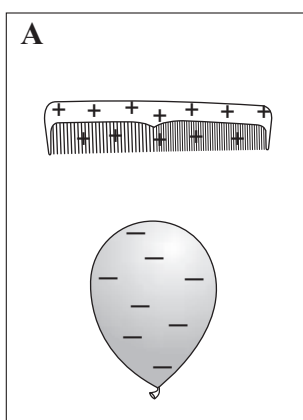

.....

.....

.....

(3 marks)

(c) The following sentences describe how a photocopier uses static electricity to make a photocopy. The sentences are in the wrong order.

- A The charge left on the plate has the same pattern as the black parts of the original page.
- B The paper is heated to make the powder stick; this is now a photocopy of the original page.
- C The copying plate is given a charge. An image of the page to be copied is projected onto the plate.
- D The charged parts of the plate attract particles of black powder.
- E The black powder is transferred from the plate onto a piece of paper.
- F Where light hits the plate, the charge leaks away.

Arrange the sentences in the right order. Start with sentence C and end with sentence B.



(3 marks)

7

TURN OVER FOR THE NEXT QUESTION

Turn over ►

7 The table shows how the count rate from a radioactive substance changes in 10 days.

Time in days	0	2	4	6	8	10
Count rate in counts per minute	880	555	350	220	140	90

(a) Draw a graph of count rate against time.

The first two points have been plotted for you.

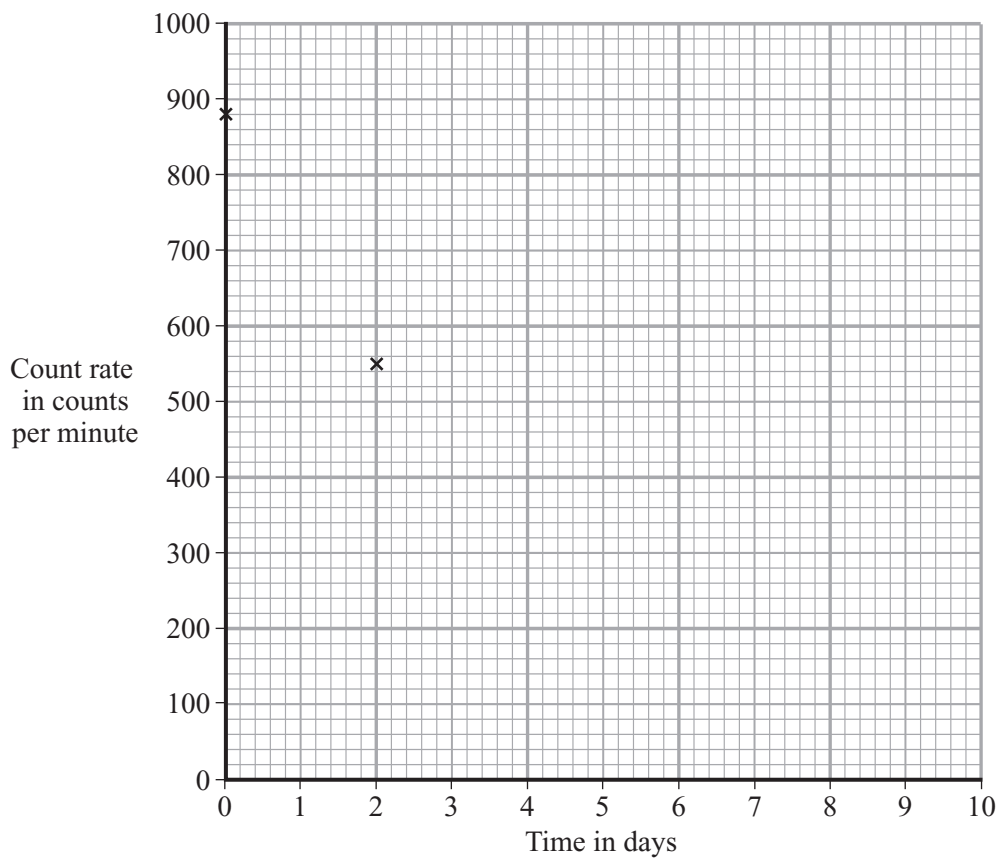

(3 marks)

(b) (i) Use your graph to find out how long it takes for the count rate to fall from 880 counts per minute to 440 counts per minute.

Time = days
(1 mark)

(ii) What is the half-life of this substance?

Half-life = days
(1 mark)

- (c) The table gives the half-life and type of radiation given out by four different radioactive isotopes.

Radioactive isotope	Half-life in days	Radiation given out
bismuth-210	5.0	beta
polonium-210	138.0	alpha and gamma
radon-222	3.8	alpha
thorium-234	24.1	beta and gamma

Some samples of each isotope have the same count rate today. Which sample will have the lowest count rate one month from today?

.....

Give a reason for your answer.

.....

(2 marks)

7

TURN OVER FOR THE NEXT QUESTION

Turn over ►

- 8 (a) Scientists think that South America and Africa were once joined together. The diagram gives evidence for this idea.

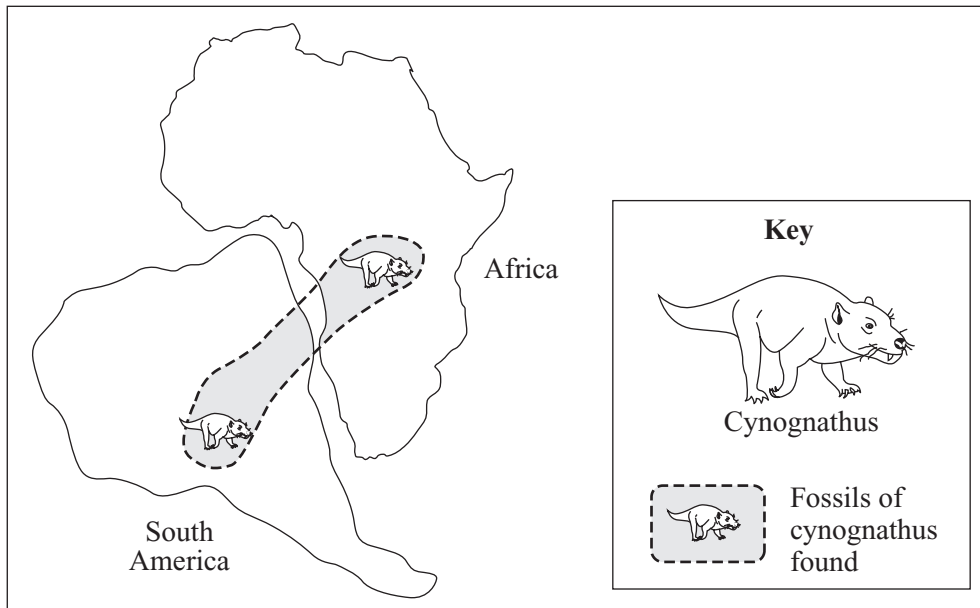

Which **two** of the following statements give evidence that Africa and South America were once joined together?

Tick (✓) the box next to each of your choices.

There are active volcanoes in Africa and South America.

Fossils of cynognathus are found in Africa and South America.

The shapes of the west coast of Africa and the east coast of South America almost fit together.

There are deserts in Africa and South America.

Earthquakes occur in Africa and South America.

(2 marks)

- (b) Complete these sentences by choosing the correct words from the box.
Each word may be used once or not at all.

continental	crust	earthquake	evolution
mantle	mountain	tectonic	

The theory of drift can explain how Africa and South America moved apart and why both have mountain ranges. Many scientists did not agree with the theory. They thought that mountains were formed because the Earth had cooled down, making the shrink. Many years later other scientists found that the Earth's lithosphere was broken into a number of large pieces. These pieces, called plates, are moving apart very slowly.

(3 marks)

5

TURN OVER FOR THE NEXT QUESTION

Turn over ►

9 The circuit shown has four identical ammeters.

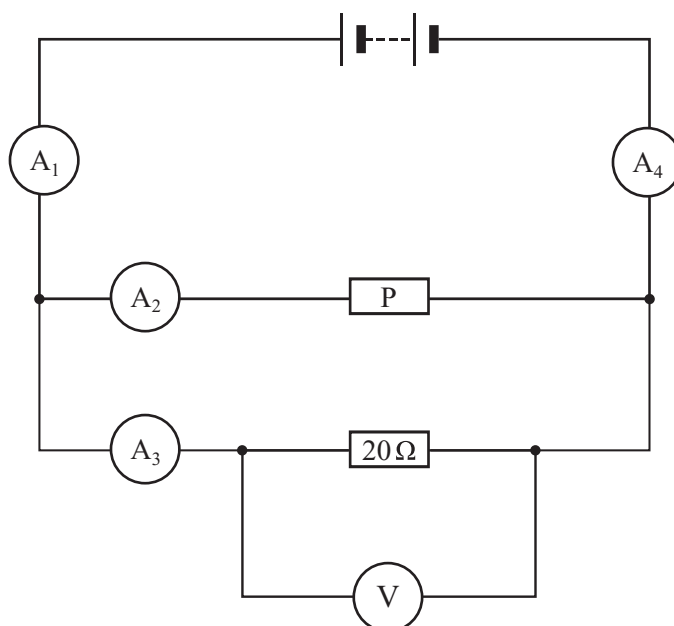

(a) The table gives the current through two of the ammeters.

(i) Complete the table to show the current through the other two ammeters.

Ammeter	Reading on ammeter in amps
A ₁	
A ₂	0.2
A ₃	0.3
A ₄	

(2 marks)

(ii) Which **one** of the following statements is correct. Tick (✓) the box next to your choice.

The resistance of **P** is more than 20 Ω.

The resistance of **P** is equal to 20 Ω.

The resistance of **P** is less than 20 Ω.

Give a reason for your choice.

.....

.....

.....

(2 marks)

- (b) (i) Write down the equation that links current, potential difference and resistance.

.....
(1 mark)

- (ii) Calculate the reading on the voltmeter. Show clearly how you work out your answer.

.....
.....

Voltmeter reading = volts.
(2 marks)

- (iii) State the potential difference of the power supply.

.....
(1 mark)

- (c) A second circuit contains an unknown component labelled X.

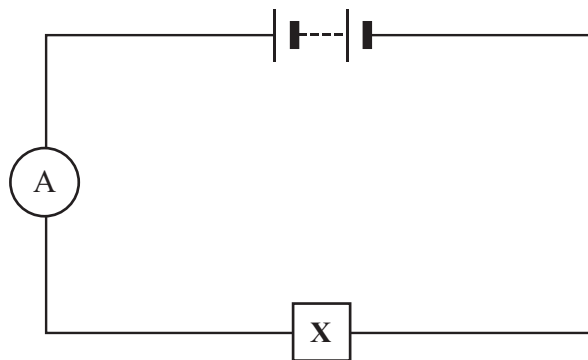

As component X is heated, the reading on the ammeter goes up.

What is component X?

.....

Give a reason for your answer.

.....
.....

(2 marks)

10

Turn over ►

- 10 (a) The chart shows that the time taken by a planet to orbit the Sun depends on its distance from the Sun.

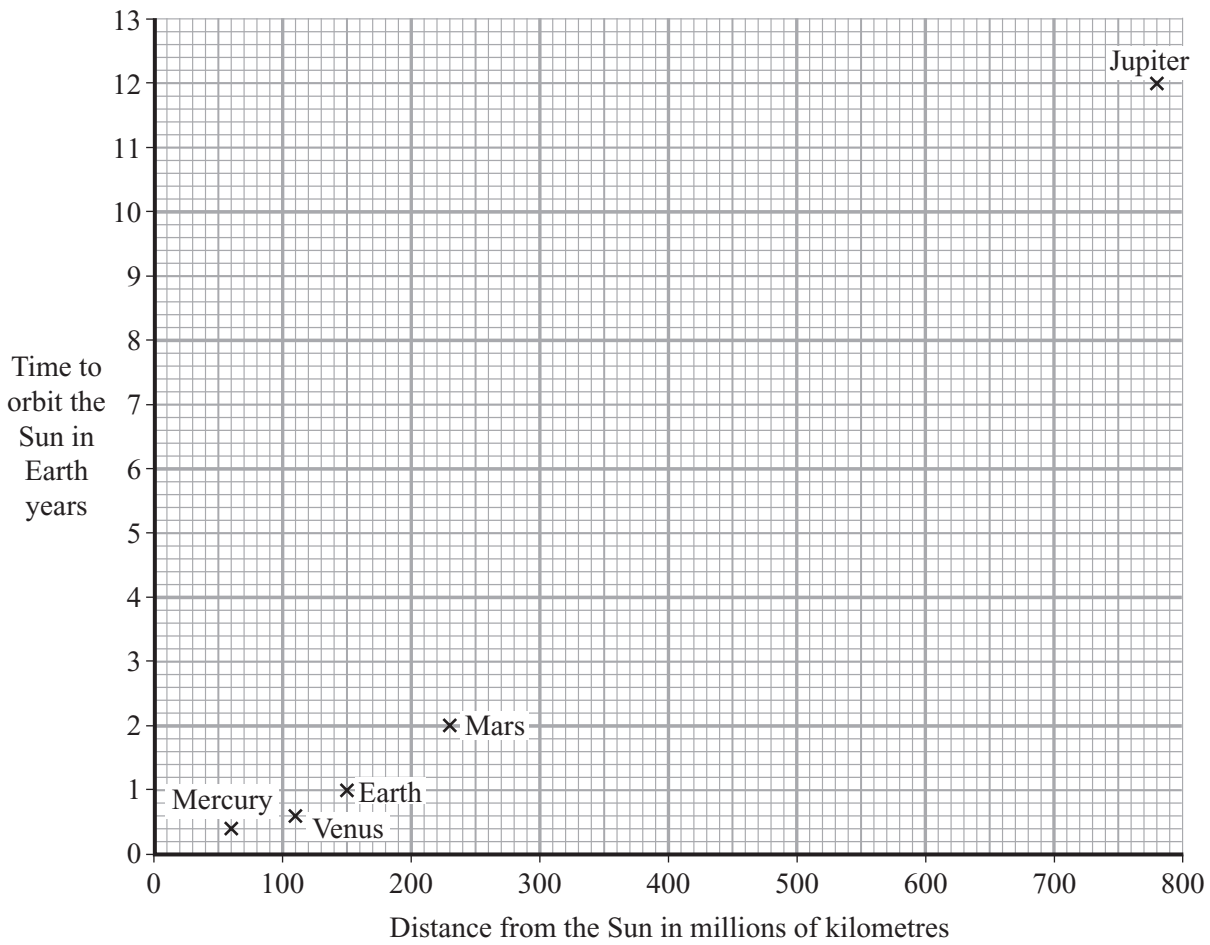

- (i) How does the time taken by a planet to orbit the Sun depend on the distance the planet is from the Sun?

.....

(1 mark)

- (ii) Asteroids orbit the Sun. One asteroid is 550 million kilometres from the Sun.

Estimate how long this asteroid takes to orbit the Sun.

Time to orbit the Sun = Earth years
 (1 mark)

- (b) The atmosphere on Venus contains a large percentage of a greenhouse gas.

	Mercury	Venus	Earth
Average surface temperature	230 °C	470 °C	20 °C

- (i) Which **one** of these gases increases the greenhouse effect? Draw a ring around your answer.

argon

carbon dioxide

nitrogen

oxygen

(1 mark)

- (ii) Explain how the information in the table and the chart shows that the atmosphere of Venus produces a greenhouse effect.

.....

.....

.....

.....

(2 marks)

5

TURN OVER FOR THE NEXT QUESTION

Turn over ►

- 11 (a) The diagram shows the ways in which heat energy can be transferred from an old house.

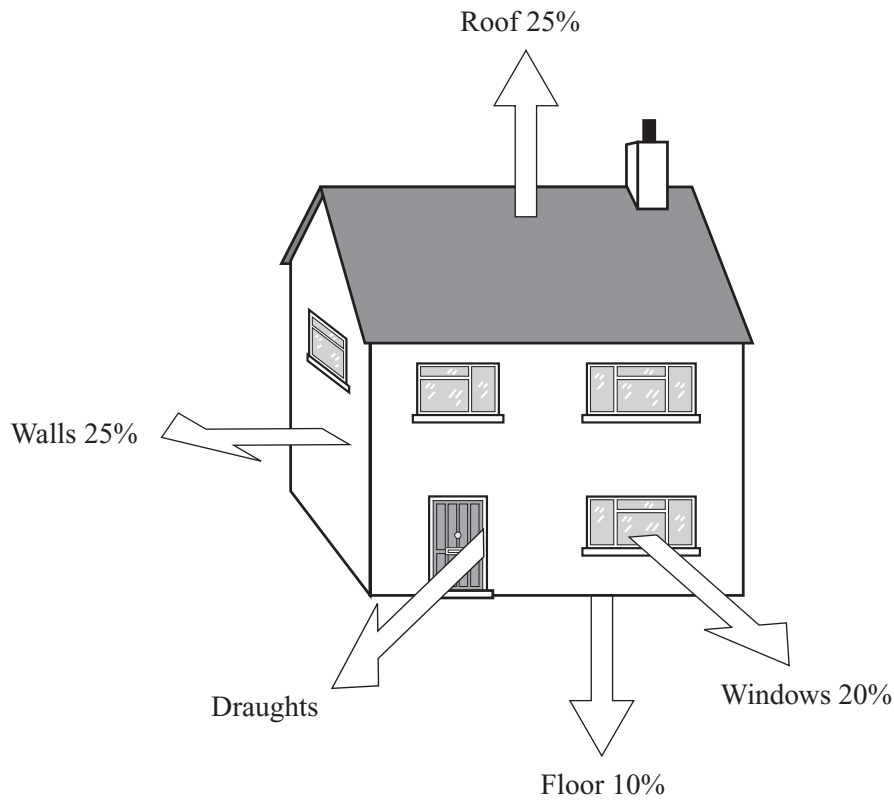

- (i) Calculate the percentage of energy transferred by draughts.

.....

% energy transferred by draughts =
(1 mark)

- (ii) Complete the following sentence using **one** of the words from the box.

conduction	convection	radiation
-------------------	-------------------	------------------

Draughts transfer heat energy by
(1 mark)

- (iii) State **one** way of reducing the heat transfer by draughts.

.....
(1 mark)

(b) The diagram shows a section through the walls of a house built in 1930.

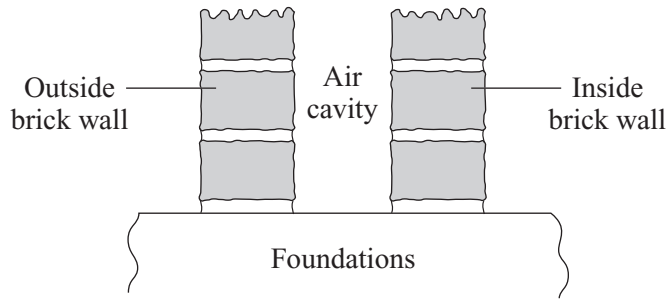

Explain how the air cavity between the two walls reduces the heat transfer from the house.

.....

.....

.....

.....

(2 marks)

(c) The table shows the installation costs and yearly savings on energy bills for different methods of insulating a house.

Method of insulation	Installation cost in £	Yearly saving on energy bills in £
Double glazing	4000	65
Loft insulation	240	60
Cavity wall insulation	600	80

(i) Give **one** reason why loft insulation is often fitted to an old house before double glazing or cavity wall insulation.

.....

.....

(1 mark)

(ii) The time it takes for the saving on energy bills to equal the cost of installing the insulation is called the pay-back time.

Calculate the pay-back time for loft insulation.

.....

Pay-back time = years
(1 mark)



Turn over ►

- 12 (a) The diagram shows the horizontal forces that act on a **moving** motorbike.

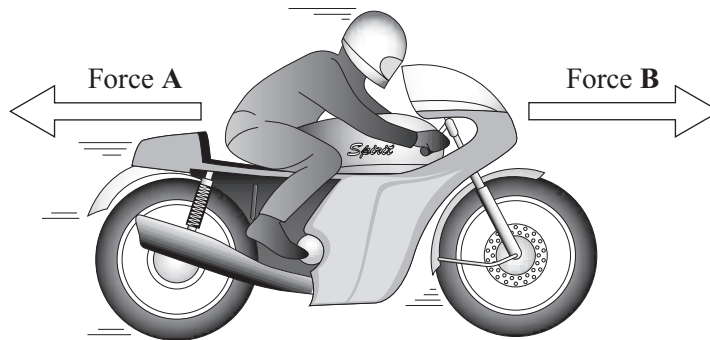

- (i) Describe the movement of the motorbike when force **A** equals force **B**.

.....

 (2 marks)

- (ii) What happens to the speed of the motorbike if force **B** becomes smaller than force **A**?

.....
 (1 mark)

- (b) The graph shows how the velocity of a motorbike changes when it is travelling along a straight road.

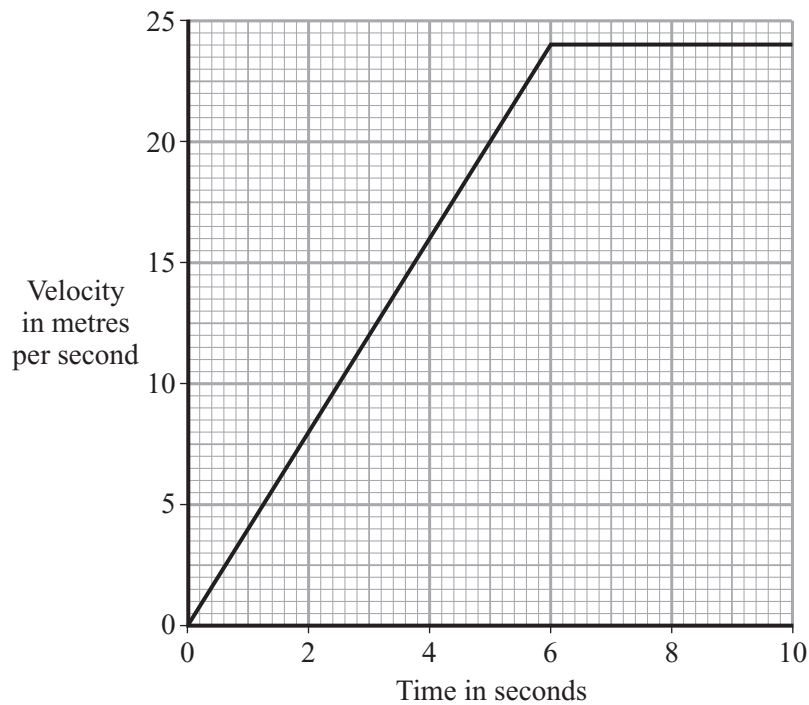

(i) What was the change in velocity of the motorbike in the first 5 seconds?

.....
(1 mark)

(ii) Write down the equation which links acceleration, change in velocity and time taken.

.....
(1 mark)

(iii) Calculate the acceleration of the motorbike during the first 5 seconds. Show clearly how you work out your answer and give the unit.

.....
.....

Acceleration =
(3 marks)

(c) A car is travelling on an icy road.

Describe and explain what might happen to the car when the brakes are applied.

.....
.....
.....
.....
(2 marks)

(d) Name **three** factors, other than weather conditions, which would increase the overall stopping distance of a vehicle.

1
.....
2
.....
3
.....
(3 marks)

- 13 (a) A microphone connected to an oscilloscope picks up the sound from a siren. The trace produced on the oscilloscope screen is shown below.

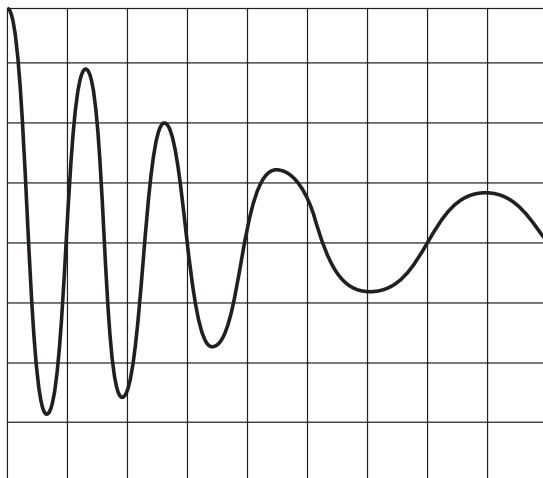

Describe how the wave changes as it goes across the screen from left to right (→).

To gain full marks in this question you should write your ideas in good English. Put them into a sensible order and use the correct scientific words.

.....

(3 marks)

- (b) An African bat produces a sound wave with a frequency of 212 kHz and a wavelength of 0.0016 m.

- (i) The sound made by the bat is above the limit of human hearing. What name is given to this type of sound?

.....

(1 mark)

- (ii) Write down the equation that links frequency, wavelength and wave speed.

.....

(1 mark)

- (iii) Calculate the speed of this sound wave through the air. Show clearly how you work out your final answer.

.....

Wave speed = m/s
 (3 marks)

8

END OF QUESTIONS