

Surname						Other Names					
Centre Number						Candidate Number					
Candidate Signature											

Leave blank

General Certificate of Secondary Education
June 2003

RELIGIOUS STUDIES (SPECIFICATION C) 3063/8/5
RELIGIOUS STUDIES (SPECIFICATION C) (SHORT COURSE)
Paper 5 Judaism



Tuesday 17 June 2003 1.30 pm to 3.00 pm

No additional materials are required.
--

For Examiner's Use			
Number	Mark	Number	Mark
A1			
A2			
A3			
B4			
B5			
C6			
C7			
QWC			
Total (Column 1)	→		
Total (Column 2)	→		
TOTAL			
Examiner's Initials			

Time allowed: 1 hour 30 minutes

Instructions

- Use blue or black ink or ball-point pen.
- Fill in the boxes at the top of this page.
- Answer **all** questions.
- Write your answers to Parts A and B in the spaces provided in this booklet.
- Write your answers to Part C on the continuation sheets at the end of this booklet.
- If you use any additional sheets, tie them loosely to the back of the booklet.
- Do all rough work in this booklet or on the continuation sheets. Cross through any work that you do not want marked.

Information

- The maximum mark for this paper is 83.
- The number of marks is given in brackets at the end of each question or part-question.
- You will be awarded up to 3 marks for quality of written communication.
- You are required to:
 - Present relevant information in a form that suits its purposes.
 - Ensure that text is legible and that spelling, punctuation and grammar are accurate so that the meaning is clear.
 - Use a suitable structure and style of writing.
- Pages 9 and 10 are perforated. You may remove these pages if you wish.

PART A

Answer **all** questions in this part in the spaces provided.

A1 Dietary Laws

Describe **two** ways in which a Jewish kitchen is organised so that it keeps Jewish dietary laws.

1.....

 2.....

(2 marks)

—
2

A2 Divorce and Abortion

Explain Jewish attitudes to

(a) Divorce

.....

(3 marks)

(b) Abortion.

.....

(3 marks)

—
6

A3 Tenakh, Talmud and Halakhah

(a) Name the **three** parts of the Tenakh.

1

.....

2

.....

3

.....

(3 marks)

(b) (i) What is the Mishnah?

.....

.....

.....

.....

(2 marks)

(ii) What is the Gemara?

.....

.....

.....

.....

(2 marks)

7

PART B

Answer **all** questions in this part in the spaces provided.

B4 Mezuzah and the Shema

Look at the drawing of a mezuzah below.

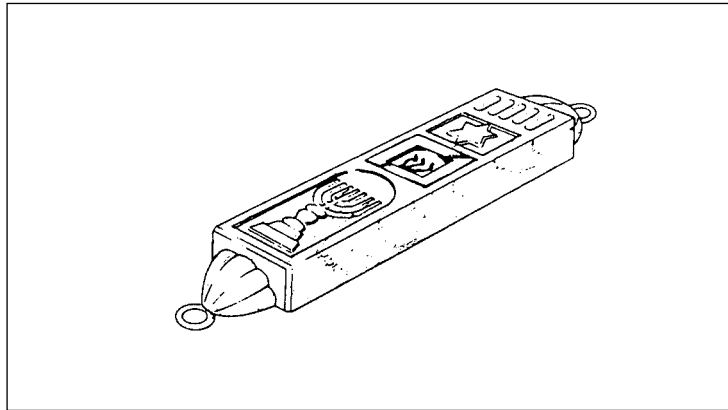

- (a) (i) Describe where a mezuzah case is attached in a Jewish home.

.....

.....

(1 mark)

- (ii) What is the importance of a mezuzah for Jews?

.....

.....

.....

.....

.....

.....

(3 marks)

(b) How do the words of the Shema remind Jews that God should be in every part of their lives?

.....

.....

.....

.....

.....

.....

.....

.....

.....

.....

(4 marks)

(c) “Keeping the Jewish laws is not possible today.”

Do you agree? Give reasons for your answer, showing that you have thought about more than one point of view.

.....

.....

.....

.....

.....

.....

.....

.....

.....

.....

.....

.....

.....

.....

.....

.....

.....

.....

.....

.....

.....

.....

.....

(5 marks)

Turn over ▶

B5 Marriage

Look at the photograph below.

The photograph showing a Jewish wedding is not reproduced here due to third-party copyright constraints.
□
The full copy of this paper can be obtained by ordering 3063/8/5□
from AQA Publications□
Tel: 0161 953 1170□

(a) Name **two** things the marriage service says God created.

1

.....

2

.....

(2 marks)

(b) What beliefs about marriage are shown by the customs at a Jewish wedding?

Dotted lines for writing.

(5 marks)

(c) "Women are equal to men in a Jewish marriage."

Do you agree? Give reasons for your answer, showing that you have thought about more than one point of view.

Dotted lines for writing.

(5 marks)

Turn over ▶

PART C

You may remove this page if you wish.

Answer **all** questions in this part on pages 11 to 16.

Each question carries 20 marks.

C6 Festivals

- (a) Describe and explain how an Orthodox Jewish family celebrates

EITHER Shabbat

OR Rosh Hashanah *(10 marks)*

- (b) Explain what Shabbat **and** Pesach show about the Jewish understanding of God. *(5 marks)*

- (c) “Rosh Hashanah and Yom Kippur are the most important festivals in the Jewish calendar.”

Do you agree? Give reasons for your answer, showing that you have thought about more than one point of view. *(5 marks)*

C7 Family and Prejudice

- (a) Explain the importance of the family in the Jewish religion. *(8 marks)*

- (b) Describe and explain Jewish teaching on prejudice and discrimination. *(7 marks)*

- (c) “The Holocaust has strengthened the Jewish faith.”

Do you agree? Give reasons for your answer, showing that you have thought about more than one point of view. *(5 marks)*

END OF QUESTIONS

Permission to reproduce all copyright material has been applied for. In some cases, efforts to contact copyright owners have been unsuccessful and AQA will be happy to rectify any omissions of acknowledgements in future papers if notified.