

GATEWAY SCIENCE SUITE
BIOLOGY, CHEMISTRY AND PHYSICS
**CANDIDATE STYLE
ANSWERS**

VERSION 1 OCTOBER 2011

INDEX

Introduction	3
Physics - Candidate A	4
Physics - Candidate B	16
Biology - Candidate C	27
Biology - Candidate D	40
Chemistry - Candidate E	57
Chemistry - Candidate F	69

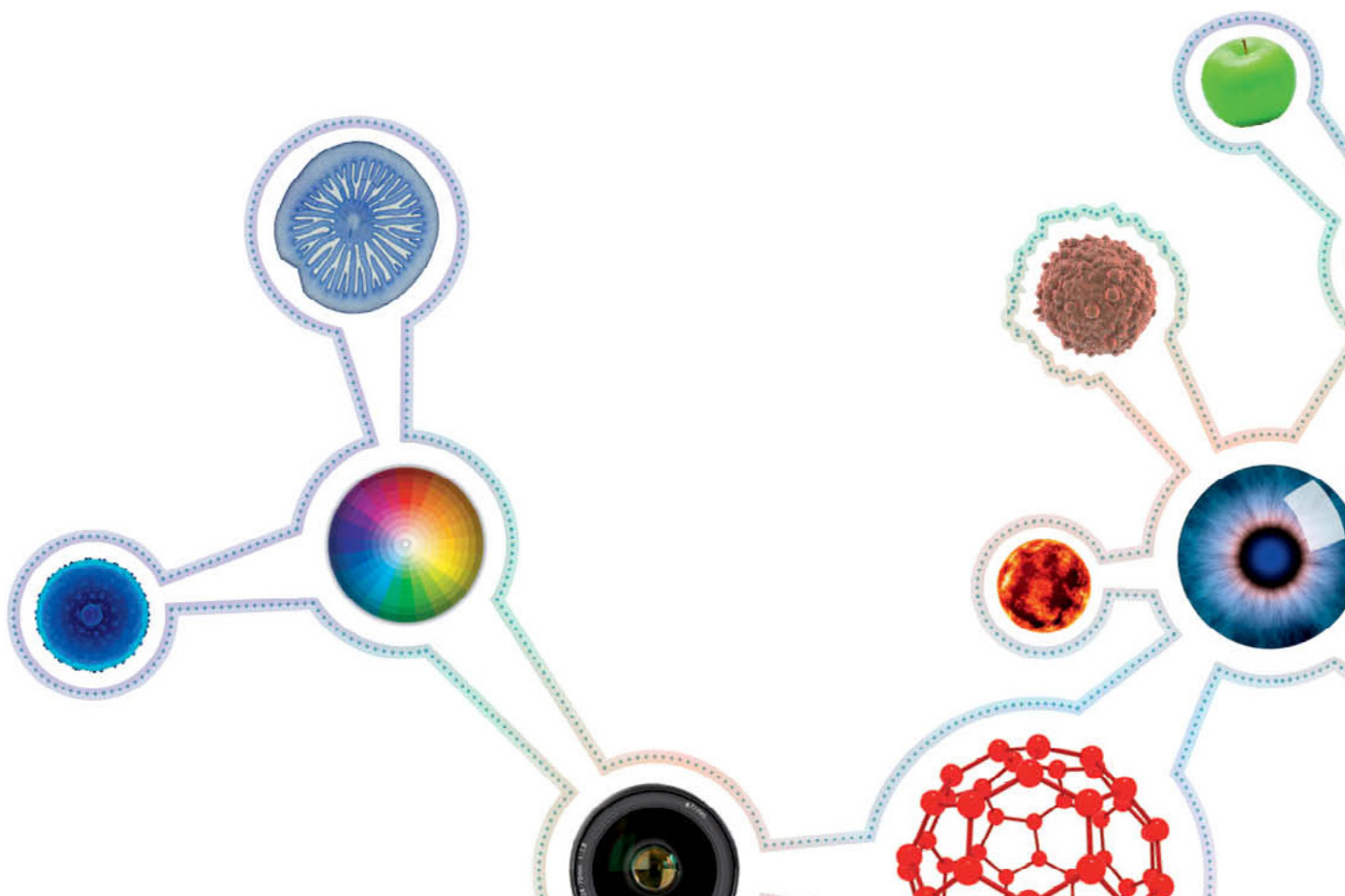

INTRODUCTION

These support materials are intended to support teachers in their marking. For each science subject there are two candidate style responses with accompanying commentary. These exemplars are based on the published Specimen Assessment Materials (SAMs), which can be downloaded from the relevant OCR webpage for each specification.

The exemplars and commentaries should be read alongside the Specifications and the Guide to Controlled Assessment for GCSE Gateway Science, all of which are available from the website.

OCR will update these materials as appropriate. Centres may wish to use these support materials in a number of ways:

- teacher training in interpretation of the marking criteria
- departmental standardisation meetings
- exemplars for candidates to review

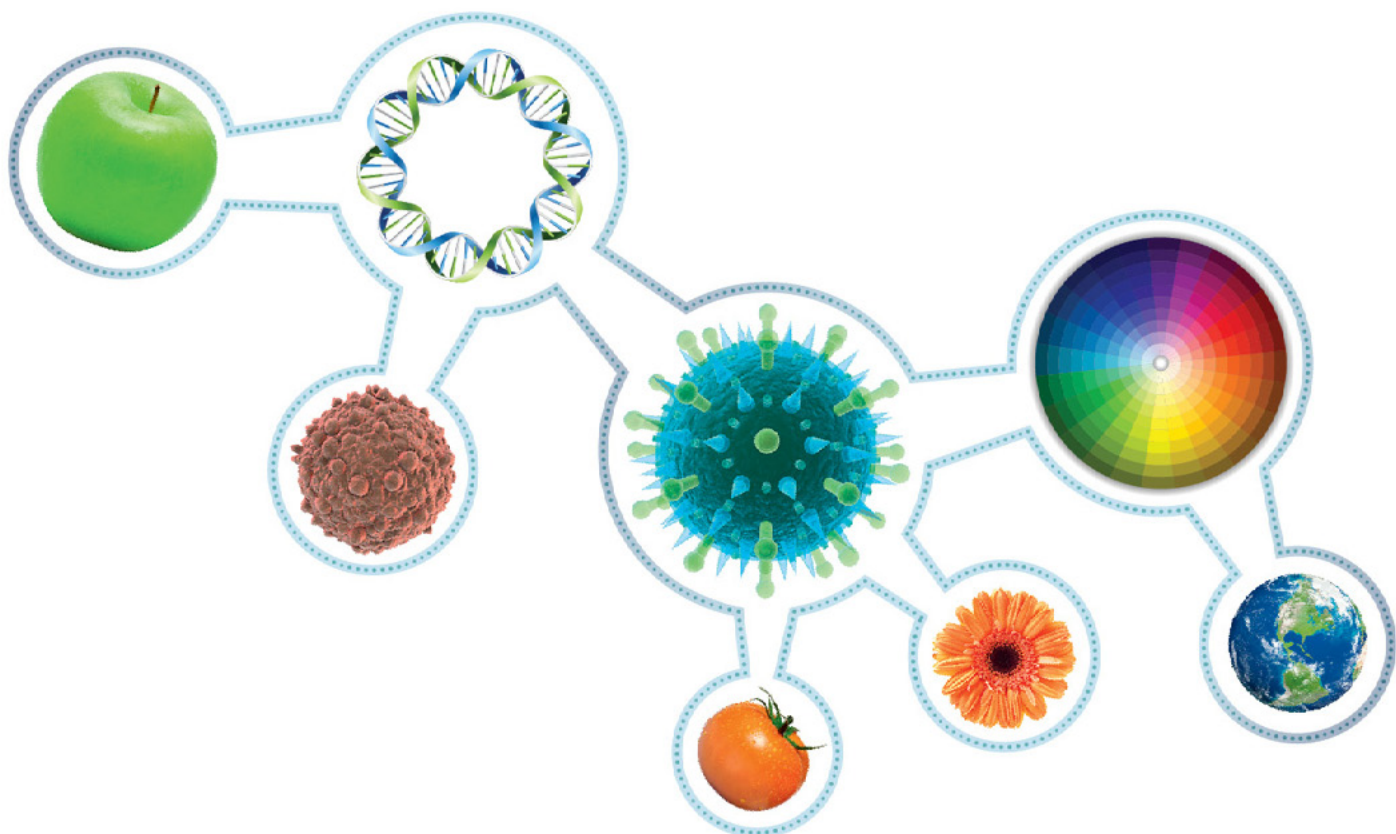

PHYSICS

CANDIDATE A

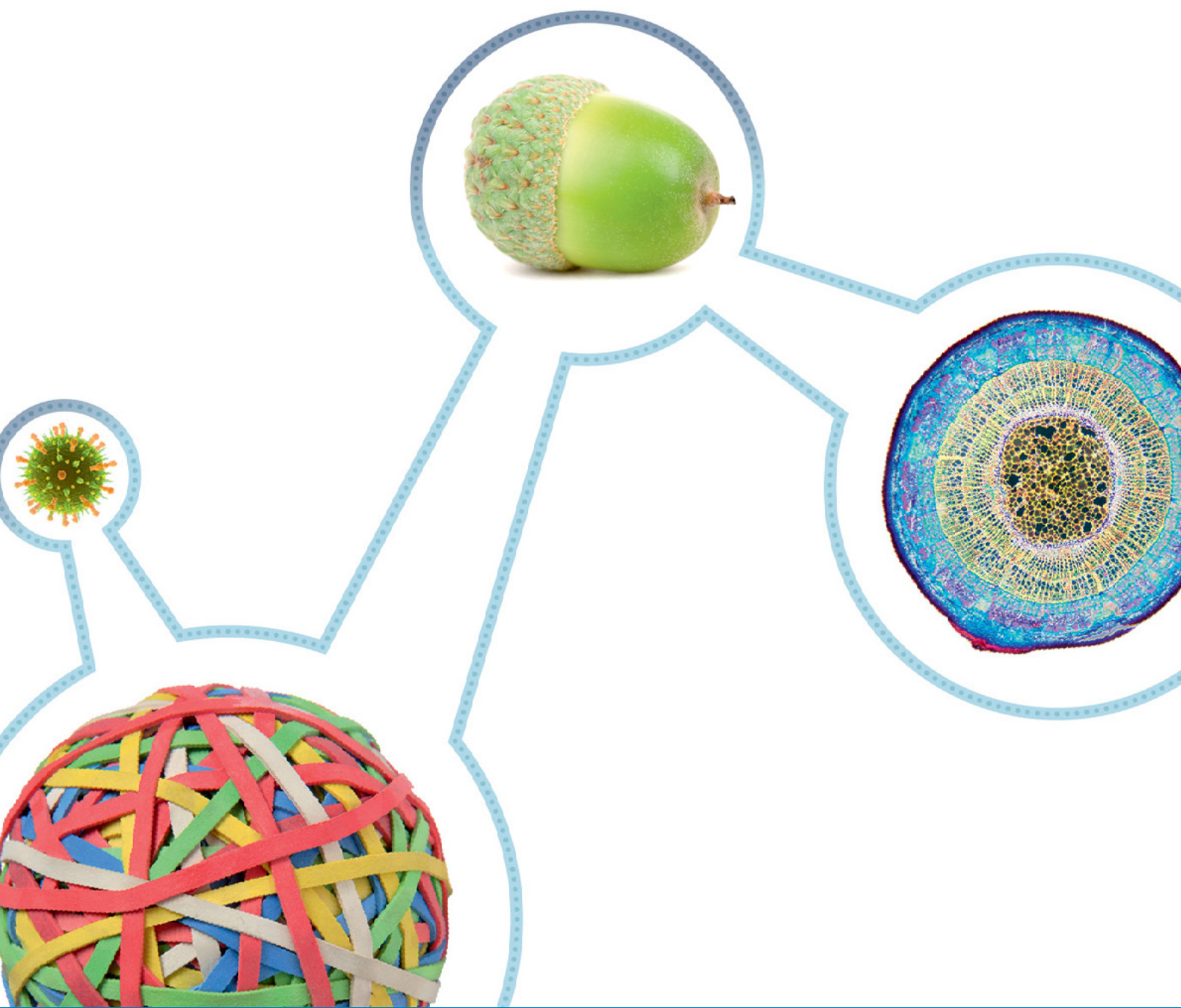

Speaker Wires Research

The advice that I have found from my research (1) is to measure the distance between the home cinema or hi-fi system and the speakers and use this distance to choose which gauge of wire to use. The distances used were given in feet so I used a website (2) to convert them to metres. If the distance is less than 60 feet (18.3m) use 16 gauge wires, between 60 feet (18.3m) and 180 feet (54.9m) use 14 gauge wires and use 12 gauge wires for distances greater than 180 feet (54.9m).

For the wires used in home cinema and hi-fi systems the resistance of the wires is the most important property of the wire. The resistance is affected by both the length and cross-sectional area of the wires. When the length is decreased and the thickness is increased the resistance becomes smaller (2).

The resistance of a wire is directly proportional to the length of the wire and inversely proportional to the cross-sectional area of the wire (3). This means that when the length of the wire is doubled its resistance doubles and when the cross-sectional area is doubled the resistance is halved.

The wire gauge shows how big a wire is. It tells you what its diameter is. It is important for electrical wiring because you can use it to find out what the resistance of the wire is (4).

The table shows the gauge (SWG), diameter and resistance for copper wires (5).

SWG	Resistance of 1m (ohms)	Diameter (mm)
14	0.005	2.11
16	0.008	1.63
18	0.015	1.22
20	0.026	0.91
22	0.043	0.71
24	0.070	0.56
26	0.105	0.46
28	0.155	0.38
30	0.221	0.32
32	0.292	0.27
34	0.402	0.23
36	0.589	0.19
38	0.945	0.15
40	1.480	0.12

The table shows that when the diameter and cross sectional area of the wire become bigger the resistance becomes smaller if the length of the wire is kept the same. It also shows that when the gauge of the wire increases its resistance gets bigger. This is because the area of the wire has become smaller.

When the resistance of the wire becomes smaller it is harder for the charge to move through the wire because there is not as much room for the charges to move past the atoms in the metal.

Bibliography

- (1) <http://www.customaudiovideoinstallation.com/1433/speaker-wiring-choosing-home-theater-speaker-wire/>
- (2) http://www.simetric.co.uk/feet_to_metres.php
- (3) http://en.wikipedia.org/wiki/Speaker_wire
- (4) http://en.wikipedia.org/wiki/Wire_gauge
- (5) <http://www.esr.co.uk/electronics/cable-copper.htm>

Speaker wires: Planning and collecting data

Hypothesis

When George changed the wires to ones with a smaller gauge he changed the wires to ones that are thicker with a smaller resistance. It is this reduction in resistance that will have caused an improvement in the quality of sound from the speakers.

The sound quality will improve when wire with a smaller gauge is used because the resistance of the wires will have been made smaller. As a result the current flowing through the wires will increase for the same output voltage from the sound system. The current in the wires will be the same as the current in the speakers. This means that wires with a smaller gauge number will make the current in the speakers bigger and the sound quality better.

When the area of the wire increases the resistance will decrease, they are inversely proportional.

Investigation Plan

My plan is to take a range of wires with different swg numbers and to measure their electrical resistances. I will measure the resistance of 3 different lengths of wires and calculate the resistance of a 1 metre length from the results. I will use lengths of 1m, 30cm and 60cm.

The thickest wire that I will use is 20 swg because it is less than 1mm thick and I have been told that the thinnest wire that I can use is 32 swg. My research has shown me that the numbers go up 2 at a time so I will use 20, 22, 24, 26, 28, 30 and 32 swg wires for my experiment.

Measure Resistance

Apparatus

metre rule
wires with different thicknesses
6V battery
ammeter*
voltmeter (0 to 10V)
crocodile clips
5 connecting leads
heat proof mat

* I do not know how big the current will be so I will start by using one that measures big currents (10A) and then use one that measures a smaller one if I need to.

Method

1. Connect up the circuit using the circuit diagram using crocodile clips to connect 1m of wire to be tested into the circuit.

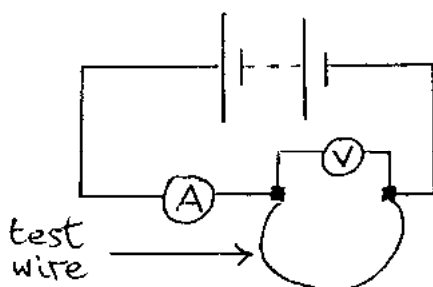

2. Measure the values of voltage and current and make a note of them in a table.
3. Disconnect the wire and use a metre rule to make the length of wire between the clips 60cm.
4. Repeat step 2.
5. Put 30cm of wire between the clips and repeat step 2.
6. Choose a wire with a different thickness and repeat step 2 for the same 3 lengths.

Safety

The wire might get hot so I will put the wire on a heat proof mat so that it doesn't burn anything. I will wear special thick gloves when touching the wires so that I do not get injured. Nobody should touch the wires with bare hands.

I am using a battery so that the voltage used is only 6V which will not cause a shock.

Errors

I will put my eye right in front of the metre rule when measuring the lengths to get an accurate measurement of length.

I am going to use the values of diameter for the wires from my research because these will be accurate.

If the wires do get hot I will leave them to cool down between experiments.

Calculations

The area of the wire is calculated using the formula; $\text{Area} = \pi d^2/4$

The resistance is calculated using the formula; $\text{resistance} = \text{voltage} \div \text{current}$

Experimental Results

swg	diameter (mm)	area (mm ²)	length (m)	Voltage (V)	Current (A)	Resistance (ohm)	Resistance per metre (ohm/m)	Average resistance per metre (ohm/m)	% difference
20	0.914	0.66	couldn't get the wire straight no measurements made						
22	0.711	0.40	1	2.04	1.59	1.28	1.28	1.29	-0.51
			0.6	1.35	1.75	0.77	1.29		-0.30
			0.3	0.94	2.41	0.39	1.30		0.82
24	0.558	0.25	1	2.6	1.22	2.13	2.13	2.13	0.21
			0.6	1.8	1.44	1.25	2.08		-2.04
			0.3	1.28	1.97	0.65	2.17		1.84
26	0.457	0.16	1	3.16	1.02	3.10	3.10	3.12	-0.73
			0.6	2.61	1.4	1.86	3.11		-0.43
			0.3	1.61	1.7	0.95	3.16		1.16
28	0.376	0.11	1	3.77	0.78	4.83	4.83	5.03	-3.90
			0.6	3.14	1.04	3.02	5.03		0.05
			0.3	2.46	1.57	1.57	5.22		3.85
30	0.315	0.08	1	3.97	0.62	6.40	6.40	6.44	-0.52
			0.6	3.39	0.88	3.85	6.42		-0.26
			0.3	2.53	1.3	1.95	6.49		0.78
32	0.274	0.06	1	4.52	0.52	8.69	8.69	8.77	-0.92
			0.6	3.88	0.74	5.24	8.74		-0.39
			0.3	3.12	1.17	2.67	8.89		1.32

Graph of resistance against area for "speaker wires"

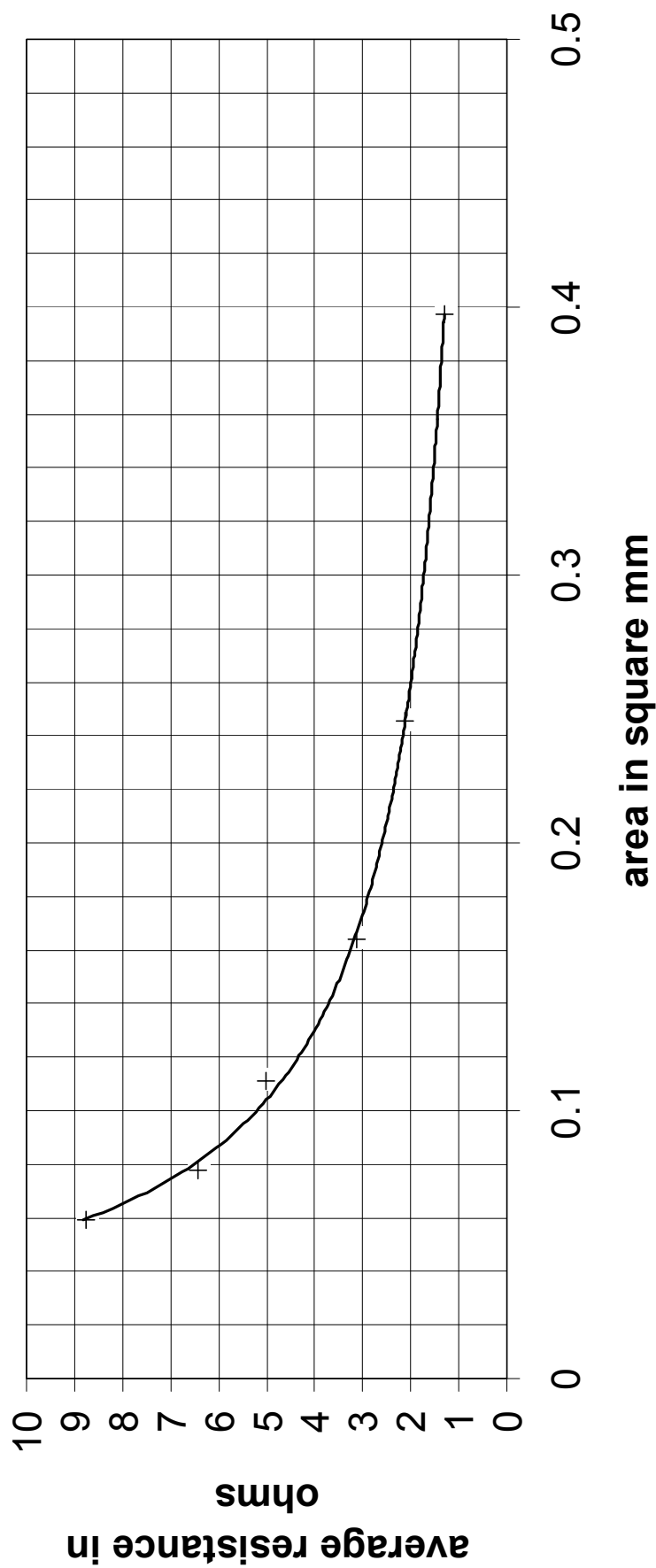

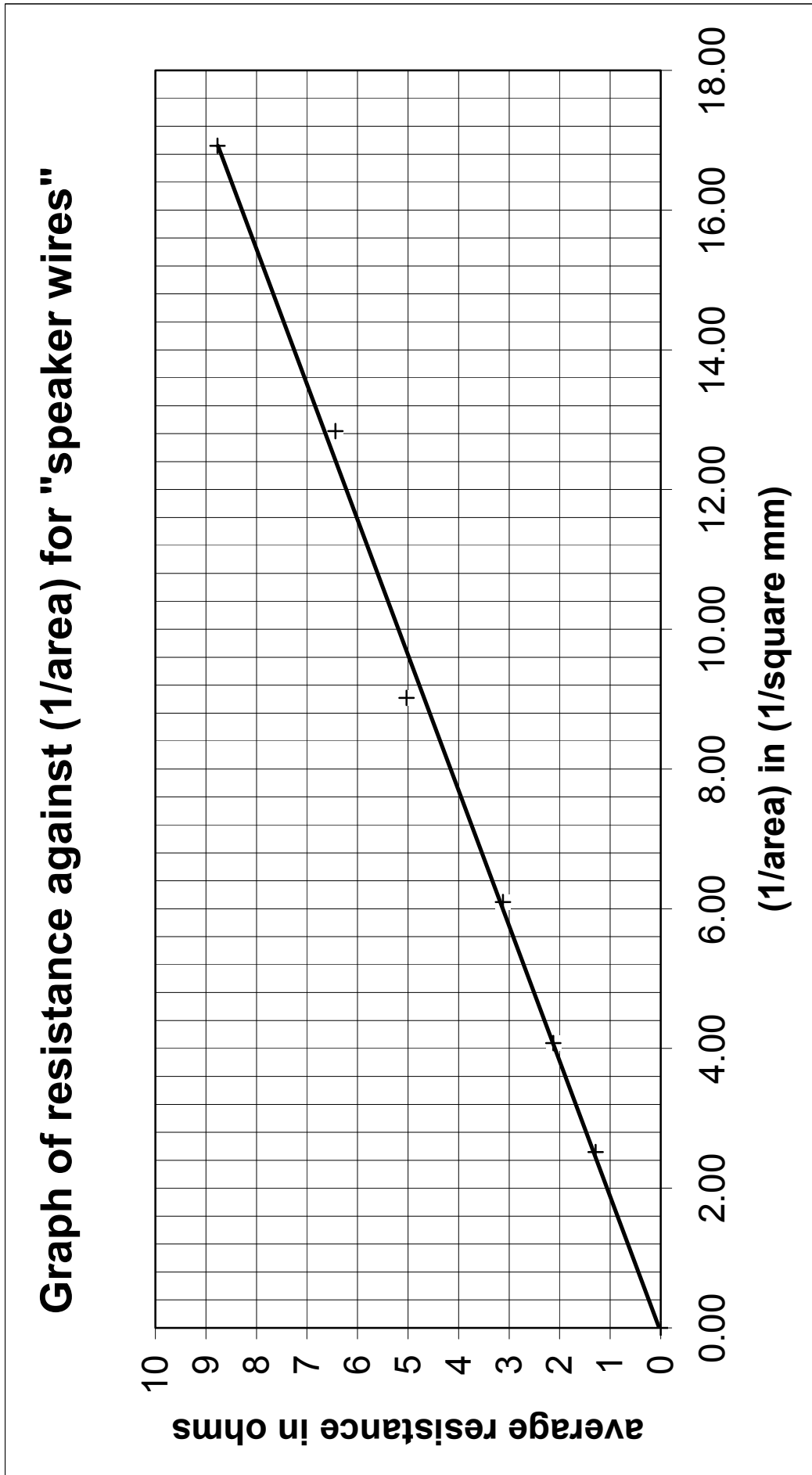

Speaker wires

In home cinema and hi-fi systems, electrical wires connect the amplifier to the speakers. The quality of the sound produced can depend upon the thickness of these wires.

- 1 Process the data you have collected and plot a graph(s) to show the results of your investigation.

Results and graphs are stapled to the booklet.

- 2 Describe any patterns or trends in your results. Comment on any unexpected results.

My results show that as the cross-sectional area of the wire increases the resistance of the wire becomes smaller. This pattern can be seen clearly on the graph of area against resistance.

The other graph shows that as $1/\text{area}$, for the wire, increases, so does the resistance of the wire.

There were no unexpected results and all the points plotted follow the same pattern and are all very close to the lines of best fit.

- 3 How do the patterns in your results compare with any patterns in the data you collected in your research?

Comment on any similarities and differences. Suggest possible reasons for any differences.

My research showed that for copper wire the resistance increased as the diameter got smaller. This is also true for my results. This happens because when the area of the wire gets bigger there is more space between the atoms in the metal to let the electrons move through the metal. When more electrons move the current is bigger.

In the table in my research a 22 swg copper wire has a resistance that is 5.1 times smaller than a 30 swg copper wire. In the experiment a metal called constantan was used and the resistance of a 22 swg constantan wire is 5.0 times smaller. These numbers are very similar.

In my research it said that the resistance of the wire and its area were inversely proportional and my results confirm this. The graph of $(1/\text{Area})$ against resistance is a straight line and it goes through the origin $(0,0)$ on the graph, which means that they are inversely proportional.

The values for resistance for copper and constantan are different. This is because they are not the same material and some materials are better conductors than others. The copper has a smaller resistance than constantan so copper is the best conductor of the two.

- 4  Evaluate your results, the method you used and how well you managed the risks.

I made a poor choice of wires to use because it was impossible to make the 20 swg wire straight so I decided not to use any data for that wire. I still used 6 values of diameter so had a good range.

It was easier to straighten the thinner wires but I think that there was still an error in measuring the length of the wire because it was not fully straight.

The digital meters have displays where the last number changes. This is not unusual and I was still able to read the meters easily.

I calculated the resistance for 3 different lengths of wire for each thickness and worked out an average value for a 1 metre length of wire. These values looked to be very close but I checked this by calculating the percentage difference between the measured values and the average values.

The last column in the table shows these percentages and they are all small which is good. The only sort of pattern that I can find in these numbers is that the biggest percentage is usually for the shortest wire. This could be because the shortest wires always have the smallest value of voltage and if there is a big error in the voltage it will be a bigger percent in a little value. It could also be because the wires were difficult to straighten.

The method gave good results because the percentage differences were small and all the points on the graphs were very close to the lines of best fit. The experiment also gave the same patterns as the ones that I found in my research.

I don't think that the wire got hot but the method I used made certain that there was no risk to anyone. It was a safe method.

- 5 Do your results from Part 2 support the hypothesis you suggested? Explain your answer.

My results do support my hypothesis very well. The graphs show that area is inversely proportional to the resistance, which is what I predicted.

It is also clear that the wires with the smallest resistance are those with the smallest swg numbers so a small swg numbered wire is the best to use to connect speakers.

- 6 Use the results from your investigation and your research to describe what factors should be considered to get good quality sound using speaker wires.

Like I said above the best wires to use for speakers are thick ones i.e. the ones with small swg numbers. This is because they have a smaller resistance so the current going to the speaker will be bigger.

I also found in my research that long wires have bigger resistances than short wires so my advice would be to make the wires to the speakers as short as possible.

Short thick wires are best.

COMMENTARY FOR CANDIDATE A

Quality	Level L, M or H	Mark	Comments
Researching	H	6	Research translated into notes which are relevant. Plenty of sources and referenced. Q6 correct.
Planning	H	5	Hypothesis long winded but OK. Plan OK but not enough detail for 6. QWC matches mark.
Collecting data	H	6	No problems thorough and complete.
Managing risk	M	4	Risk is mentioned in the plan and in Q4. No teacher comment.
Processing data	H	6	Two relevant graphs well plotted plus plenty of mathematical manipulation.
Analysing & interpreting	H	6	Inverse proportion spotted and explained. Good comparison with research data.
Evaluating	H	5	Errors not there so not commented on? QWC good. 5 marks as best fit.
Conclusion	M	4	Rather brief but plenty of science included in hypothesis and in Qs 2 and 3.
	Total	42	

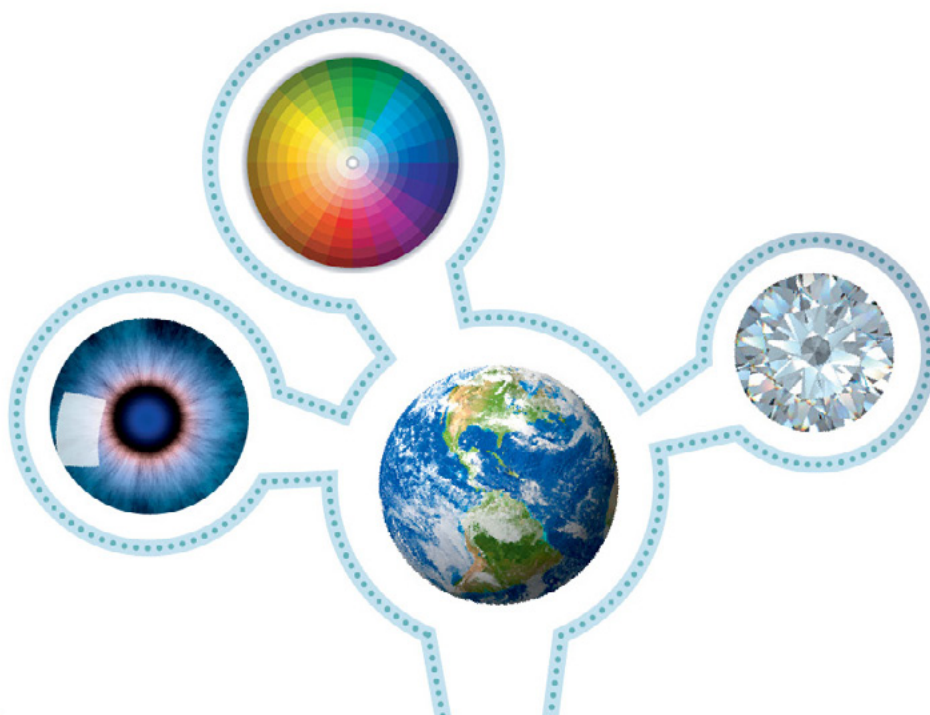

PHYSICS CANDIDATE B

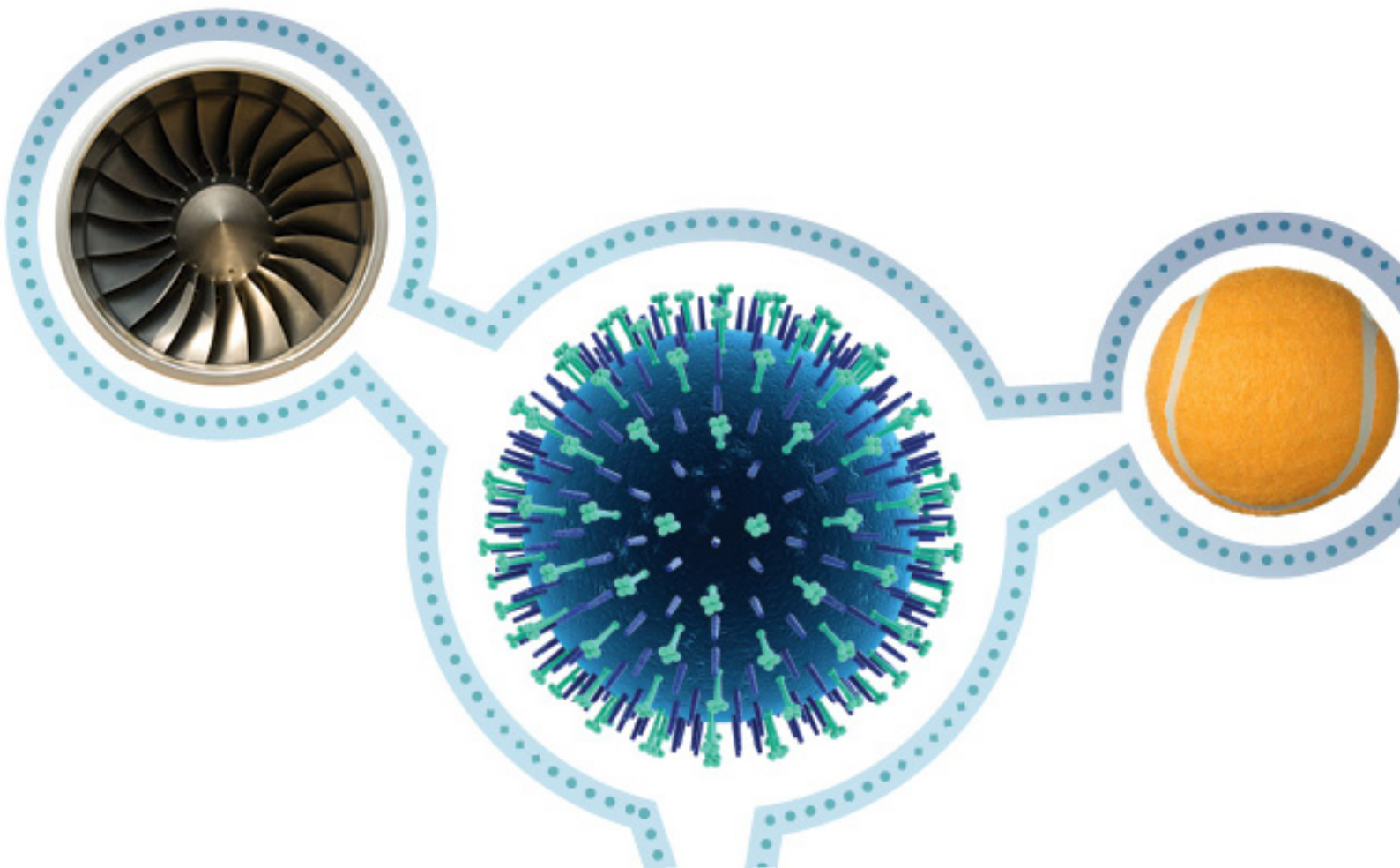

Speaker Wires

I looked up speaker wires on wikipedia and found some things for my research. It says that the most important thing is resistance.

The best thing is to have short wires with a big area. The wires only need to be so long that they can get from the amplifier to the speakers but they have to be thick. It says to use 16 gage wire.

I found out how thick the wires should be from an electronics specialist in North America called crutchfield. They had a table that showed what gauge you need.

Distance from speaker to amplifier	Gauge
Less than 80 feet	16
80 to 200 feet	14
More than 200 feet	12

This shows that for bigger distances you need to use a smaller number for the gauge.

I used another source from wikipedia to find out about american wire guage awg. This says that number determines its current-carrying capacity and electrical resistance and changes because of the way that the wire is drawn. The table has a lot of information in it but my research of it told me that as the number gets bigger the wire gets thinner. A wire that has been drawn 10 times has a diametre of 0.1019 (inch) or 2.588 (mm) and one that has been drawn 20 times is a lot thinner because it has a diametre of 0.0320 (inch) or 0.812 (mm).

This table comes from daycounter.com that I found using google.

AWG Chart				
AWG Number	Ø [Inch] for Solid Rod	Ø [mm] for Solid Rod	Ø [mm²] for Solid Rod	Resistance [Ohm/m] Copper (20 °C, 68 °F)
4/0 = 0000	0.460	11.7	107	0.000161
3/0 = 000	0.410	10.4	85.0	0.000203
2/0 = 00	0.365	9.26	67.4	0.000256
1/0 = 0	0.325	8.25	53.5	0.000323
1	0.289	7.35	42.4	0.000407
2	0.258	6.54	33.6	0.000513
3	0.229	5.83	26.7	0.000647
4	0.204	5.19	21.1	0.000815
5	0.182	4.62	16.8	0.00103
6	0.162	4.11	13.3	0.00130
7	0.144	3.66	10.5	0.00163
8	0.128	3.26	8.36	0.00206

9	0.114	2.91	6.63	0.00260
10	0.102	2.59	5.26	0.00328
11	0.0907	2.30	4.17	0.00413
12	0.0808	2.05	3.31	0.00521
13	0.0720	1.83	2.62	0.00657
14	0.0641	1.63	2.08	0.00829
15	0.0571	1.45	1.65	0.0104
16	0.0508	1.29	1.31	0.0132
17	0.0453	1.15	1.04	0.0166
18	0.0403	1.02	0.823	0.0210
19	0.0359	0.912	0.653	0.0264
20	0.0320	0.812	0.518	0.0333
21	0.0285	0.723	0.410	0.0420
22	0.0253	0.644	0.326	0.0530
23	0.0226	0.573	0.258	0.0668
24	0.0201	0.511	0.205	0.0842
25	0.0179	0.455	0.162	0.106
26	0.0159	0.405	0.129	0.134
27	0.0142	0.361	0.102	0.169
28	0.0126	0.321	0.0810	0.213
29	0.0113	0.286	0.0642	0.268
30	0.0100	0.255	0.0509	0.339
31	0.00893	0.227	0.0404	0.427
32	0.00795	0.202	0.0320	0.538
33	0.00708	0.180	0.0254	0.679
34	0.00631	0.160	0.0201	0.856
35	0.00562	0.143	0.0160	1.08
36	0.00500	0.127	0.0127	1.36
37	0.00445	0.113	0.0100	1.72
38	0.00397	0.101	0.00797	2.16
39	0.00353	0.0897	0.00632	2.73
40	0.00314	0.0799	0.00501	3.44

It shows that when the AWG number gets bigger the resistance gets bigger.

Sources used

Speaker wires on wikipedia
 crutchfield.com
 wikipedia american wire gauge
 gauge diameter and resistance using google

Hypothesis

I think that the 16 gage wires will not be as good as the ones with 12 because they are thinner. My research shows the wire gets thinner as the number gets bigger.

The thin wire will not let as much electric through because it is harder for the electricity to get through a wire with a big resistance so if not as much electric gets through the sound will not be as good with 16. More current will go through the wires if the resistance is small.

So I think that when the swg gets bigger the resistance of the wire gets bigger and the sound is not as good because there is not as much current going to the speakers.

Plan

I will do an experiment to measure resistance for different wires that I am given. I will do it 3 times for each wire and work out an average to make sure my experiment is reliable. I will measure voltage and current for the wires and use ohms law to work out the resistance. I will make it a fair test by always using the same voltage and one meter of wire.

I have drawn the circuit that I will use

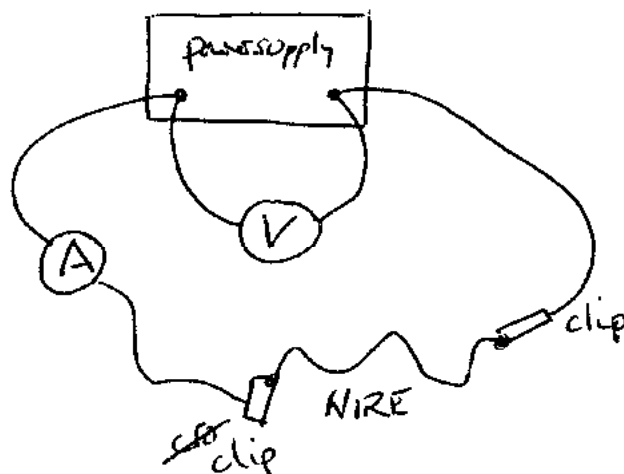

The wire might get hot so I am going to use only 5 volts and will turn the power off as soon as I have measured the the volts and amps. I will not touch the wire until it has time to cool down if it got hot.

I will need a meter stick to measure out a meter of each wire and to connect up my circuit I will need
2 crocodile clips
leads
ampmeter
voltmeter
power supply
different thickness wires

I will put my results in a table and work out the resistances by dividing current into voltage (Volts = amps x ohms)

Our Results

SWG	length	amps				volts	resistance of wire
		1	2	3	average		
22	1m	2.53	2.53	2.53	2.53	5	1.976285
26	1m	1.20	1.21	1.20	1.20	5	4.155125
30	1m	0.66	0.64	0.65	0.65	5	7.692308
34	1m	0.36	0.35	0.34	0.35	5	14.28571

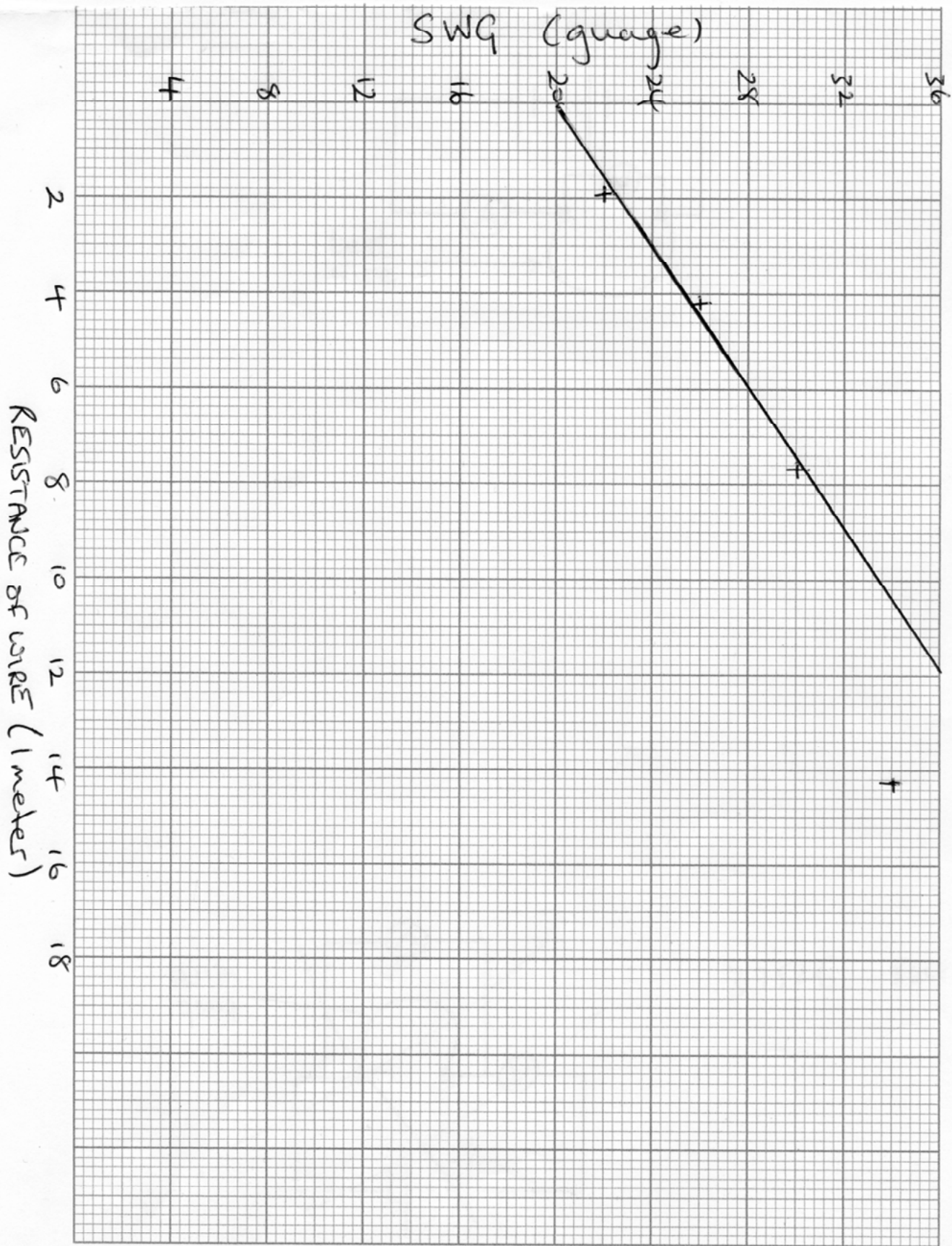

Free Multi-Width Graph Paper from <http://incompetech.com/graphpaper/multiwidth/>

Speaker wires

In home cinema and hi-fi systems, electrical wires connect the amplifier to the speakers. The quality of the sound produced can depend upon the thickness of these wires.

- 1 Process the data you have collected and plot a graph(s) to show the results of your investigation.

On separate sheets.

- 2 Describe any patterns or trends in your results. Comment on any unexpected results.

Our results are very good and agree with my prediction because the graph shows a positive correlation. The graph is a straight line and as the swg number gets bigger so does the resistance. This is what I put in my prediction.

Our last result is anomalous because it is not near the line that I have drawn and all the others are. I think that it is wrong because I was given the wrong thickness piece of wire but it might be because the ampmeter and voltmeter didnt work properly. The number at the end kept changing so the numbers we wrote down might be wrong.

- 3 How do the patterns in your results compare with any patterns in the data you collected in your research?

Comment on any similarities and differences. Suggest possible reasons for any differences.

The patterns in our results are just the same as the patterns I found in my research. All the swg numbers get bigger and so do the resistances even the one that is wrong.

The only difference is the pattern I found was for awg numbers from america but our experiment used swg from England but I think that they will be the same overall.

- 4  Evaluate your results, the method you used and how well you managed the risks.

The wires did not get hot and nothing broke so we did the experiment safely. The results were very good only one of them was wrong. We took an average of the amp readings so the experiment was accurate. We left the wires to cool down but they had not got hot.

I checked that the circuit was connected up like in my diagram and found that when the amperemeter was moved it was. We did everything carefully and accurately and wrote all the results down in a table.

It would have been better if we had been given ammeters and voltmeters that worked and did not keep changing the numbers and the number on one of the wires was wrong because the result for that one did not fit on the line.

I think that the best improvement would be to use more accurate meters but we could have made it better by taking more readings and working out an average for voltage and length.

The most accurate reading was the length because we used a meter ruler that is easy to use and is always the same length.

The method was a good one but some of the wires were not straight and so they might not all have been the same length when we did the experiment even though we measured them accurately.

- 5 Do your results from Part 2 support the hypothesis you suggested? Explain your answer.

My hypothesis is right because my graph shows a positive correlation which means that as I predicted the resistance gets bigger as the swg number gets bigger.

This happens because the big swg wire is very thin and the electricity will not get through as easily as for a thick wire because there will not be as much space between the atoms in a thin wire.

- 6 Use the results from your investigation and your research to describe what factors should be considered to get good quality sound using speaker wires.

The sound will be better if more current gets to the speaker so it is best if the resistance of the wires is small. The results of the experiment show that the best way to make the resistance small is to make the wires thick. This means that they should have a small wire guage because thicker wires have smaller guage numbers.

My research also showed that a smaller guage should be used if long wires are used.

Overall my advice is to use wires that are short and thick to get the best sound from the speakers.

COMMENTARY FOR CANDIDATE B

Quality	Level L, M or H	Mark	Comments
Researching	L	2	Relevant though brief information found. Four sources but none referenced. Possibly 3 best fit?
Planning	M	3	Hypothesis a little weak but plan not too bad. QWC also matches low middle.
Collecting data	M	4	Table OK with all figures but no units for resistance.
Managing risk	M	3/4	Possibility of hot wire mentioned in plan and in Q4. Would be 4 with a comment on plan from teacher.
Processing data	M	3	Axes reversed, plotting a little awry but within $\frac{1}{2}$ a square. 'Best fit' straight line should be a curve.
Analysing & interpreting	M	3	Correct description of pattern anomaly found and dealt with.
Evaluating	L	2	QWC not good. Basic attempt a good 2 but not in the M zone.
Conclusion	L	2	Hypothesis dealt with correctly but link with 'science' very basic.
	Total	22/23	

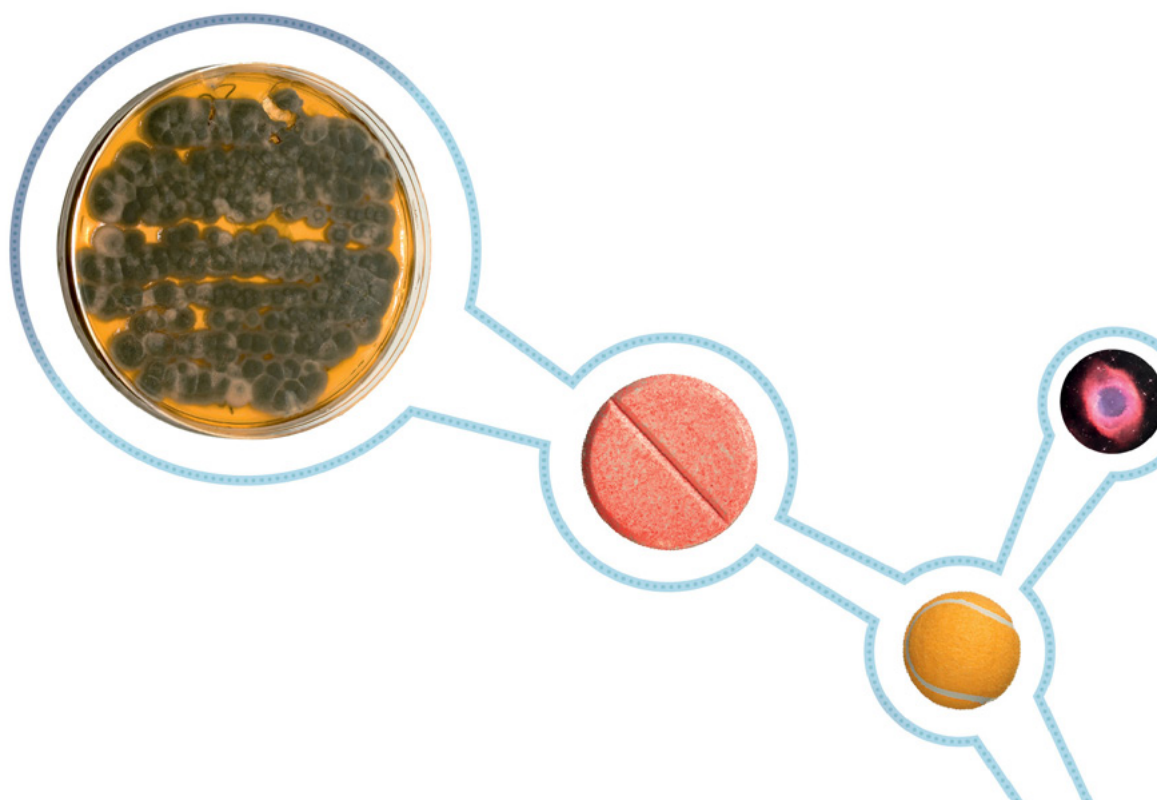

BIOLOGY

CANDIDATE C

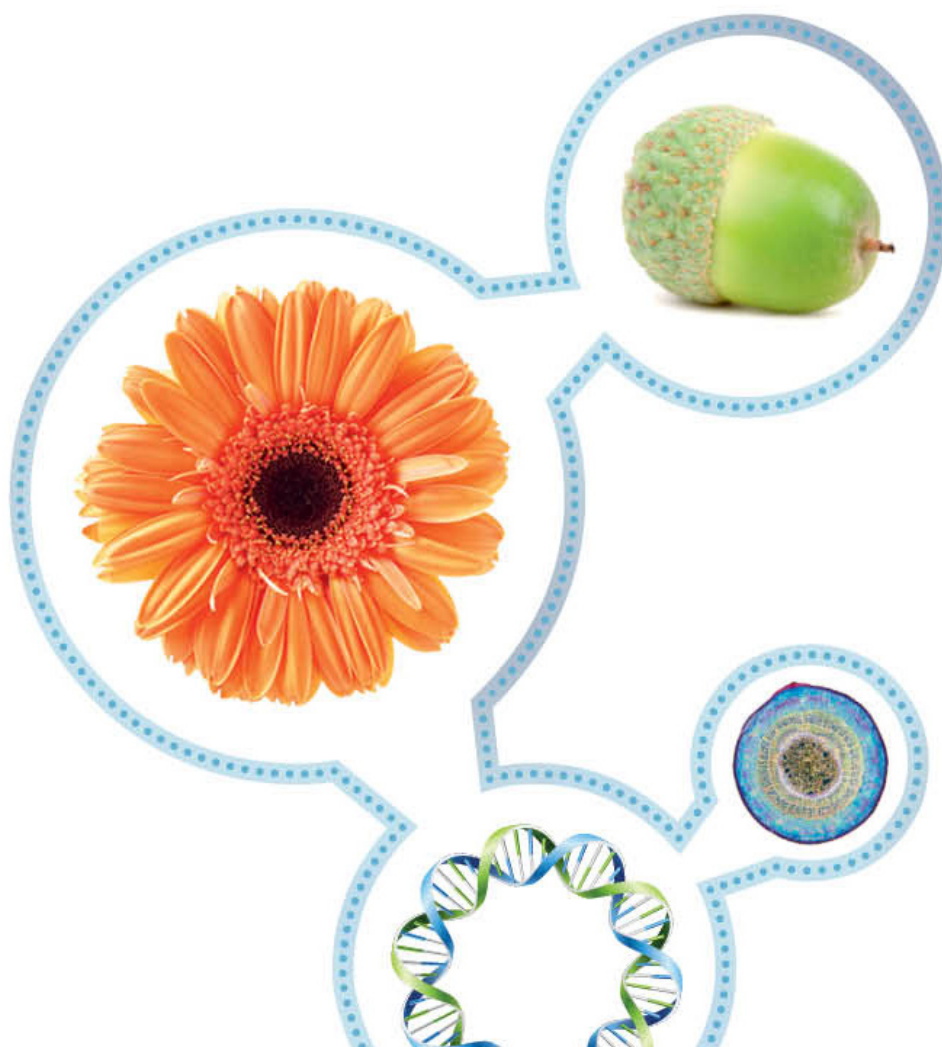

Sources

1. Enzymes

www.bbc.co.uk > [Home](#) > [Science](#) > *Additional Science*
www.thestudentroom.co.uk > ... > [Revision Notes](#) > [Biology](#) -

2. Pectinase

www.saps.org.uk/.../SAPS%20Scotland%20Fruit%20Juice%20Production

3. Commercial juice production

www.rtg.wa.edu.au/ideas/kitchen/enzymes/enzymes.htm

4 Apple juice

www.eurovolvox.org/Protocols/PDFs/AppleJuice03_UK_eng.pdf

5 Food pH

www.engineeringtoolbox.com/food-ph-d_403.html

Enzymes

Enzymes are biological catalysts. There are optimum temperatures and **pH** values at which their activity is greatest. Enzymes are also proteins, and usually denatured above about 45°C.

Enzymes are important in respiration. Aerobic respiration releases energy from glucose.

What are enzymes?

Enzymes are biological catalysts - catalysts are substances that increase the rate of chemical reactions without being used up. Enzymes are also **proteins** that are folded into complex shapes that allow smaller molecules to fit into them. The place where these **substrate** molecules fit is called the **active site**.

If the shape of the enzyme changes, its active site may no longer work. We say the enzyme has been **denatured**. They can be denatured by high temperatures or extremes of **pH**. Note that it is wrong to say the enzyme has been killed. Although enzymes are made by living things, they are proteins, and not alive.

Temperature and enzymes

As the temperature increases, so does the rate of reaction. But very high temperatures denature enzymes.

The graph shows the typical change in an enzyme's activity with increasing temperature. The enzyme activity gradually increases with temperature until around 37°C or body temperature. Then, as the temperature continues to rise, the rate of reaction falls

rapidly, as heat energy denatures the enzyme destroying the active site so the substrate molecule can no longer bind with the enzyme.

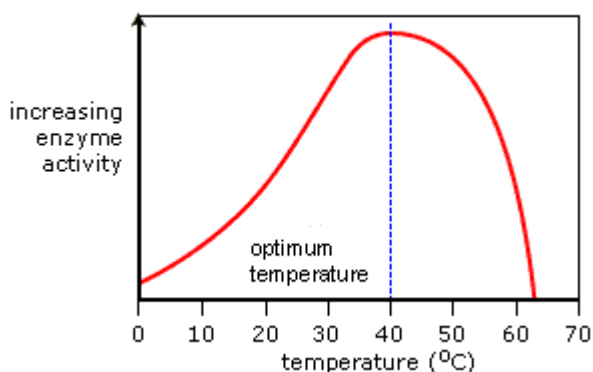

Temperature and enzyme activity

pH and enzymes

Changes in pH alter an enzyme's shape. Different enzymes work best at different pH values. The optimum pH for an enzyme depends on where it normally works. For example, intestinal enzymes have an optimum pH of about 7.5. Enzymes in the stomach have an optimum pH of about 2.

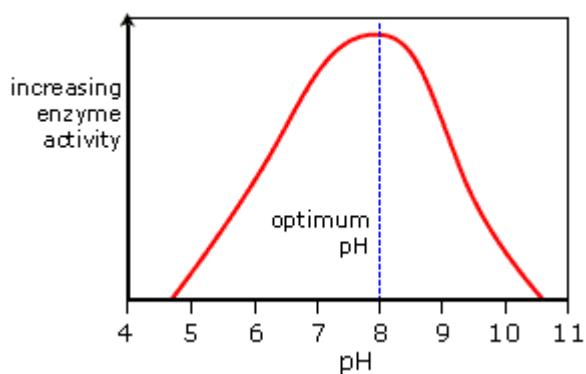

pH and enzyme activity

www.bbc.co.uk > [Home](#) > [Science](#) > *Additional Science*

Temperature

Temperature has a great impact on the activity of enzymes. Initially an increase in temperature is linked to an increase in activity of the enzyme. This is due to an increase in kinetic energy which leads to an increase in the frequency of successful collisions between the enzyme and substrate. However this is only true to an extent if the temperature is increased beyond the optimal temperature of the enzyme (which in most cases is 40-45°C), the bonds will start to break and the shape of the active site will change. This is known as denaturing.

pH

The pH of the solution which contains the enzyme has an impact on the activity of the enzyme. This is because the pH affects the ionisation state of the R group in the amino acid. So this also effects the bonding within the enzyme and the shape of the active site. Extremes of pH will denature the enzyme and stop it working as a catalyst.

www.thestudentroom.co.uk › ... › [Revision Notes](#) › [Biology](#) -

Action Pectinase

Pectinase is an enzyme that catalyzes the breakdown of pectin, a component of the cell wall in fruits such as apples and oranges. Pectinase is used commercially to aid in extracting juice from fruit. By enzymatically breaking down the cell wall, pectinase releases the juice from within the cells. Pectinase is also used for clarifying the extracted juice.

Fruit juice can be extracted from a wide variety of fruits. This can be done by simply squeezing the fruits but it is more common to use enzymes to increase the volume of juice produced and the speed of extraction. The enzymes which are used, both commercially and in this experiment, break down the cell walls within the fruits and release liquids and sugars. Fruit cell walls are very complex molecular structures and to get the maximum breakdown of the compounds found in them, fruit juice companies use a variety of different treatments and enzymes to maximise the yield of juice. Fruit is made up of cells linked by middle lamellae which contain insoluble proto-pectin. Pectinase breaks down the pectin chains and therefore reduces its binding action. The cell walls are composed largely of cellulose and hemicellulose and cellulases weaken the cell walls and make it easier to extract the juice. As the breakdown of the fruit cells continues, a variety of polysaccharides are found within the juice extract. These can cause the juice to become cloudy and reduce its market value. Pectinases and amylases can both break down these insoluble compounds releasing soluble sugars which clarify the juice producing a clearer, sweeter product. Different combinations of enzymes are used with each different type of fruit.

www.saps.org.uk/.../SAPS%20Scotland%20Fruit%20Juice%20Production

COMMERCIAL JUICE PRODUCTION

Apple Juice Production with use of Enzymes:

- **Visual inspection**– looking for mold, spray residue etc. Cut or misshapen apples are okay for juice
- **Washing**– apples are then water-washed by various methods for 10 – 45 minutes. Processors sometimes add chlorine dioxide, hypochlorite or other chlorine compounds to control microbial buildup in re-circulated water. Some washing includes physical scrubbers, which can actually reduce wash time. The extensive washing procedures effectively remove external surface dirt and topical agrochemical residues (pesticides)
- **Enzyme Use in The Mash:**From the washers, the apples are chopped up by a grinder, apple mill or a hammer mill and turned into apple mash. To produce a highly pressable mash, it should not be ground to fine, stirred or heated above 35 C (95 F). When treated with **PECTINASES** the temperature range is kept mild, from 20 – 30 C and the reaction and the reaction time is typically 30 – 120 minutes. This is in part to limit the hydrolysis of protopectin. Protopectin binds the cells and its hydrolysis weakens the fruit tissue, reduces its pressability and increases viscosity. The addition of **PECTINASE** to the mill is very beneficial especially for apples with a soft texture. **PECTINASES** developed for apple mashes contain a high

percentage of **pectin esterase** and **polygalacturonase** (aka **pectin glucosidase**). These enzymes dramatically reduce viscosity and the stickiness of the pomace without affecting protopectin or reducing its pressability. Enzyme blends that include **CELLULASE** and **HEMICELLULASE** activity can break down the cell wall and **increase** the over-all juice production by **5 – 10 %**.

o **LiquiSEB RL**- will provide significant pectinolytic activity as well as cellulase and hemicellulase side activity

o **ClariSEB**– provides even stronger pectinase activity with very little cellulase and hemicellulase activity

- The mash is then sent to hydraulic presses that squeeze the mash to extract the juice. A single press usually yields only about 60 – 70% of the juice from fresh apples. Stored apples produce less juice and their untreated pomace tends to stick to the press. This is caused by protopectin hydrolysis that occurs during ripening, which separates cells and softens the fruit.
- Water is added to the pulp residue and it is completely expressed, usually with a horizontal press. The increase in juice volume isn't great but the increasing sugar is significant. Normal juice is about 12 Brix. The second press sugar can raise the juice to 12.3 – 12.5 Brix.
- The apple juice is then pumped into holding tanks where it is filtered to remove sediment.
- If **PECTINASE** was not added during mash, it can be added to the holding tanks. The use of a product like **LiquiSEB** or **ClariSEB** will reduce viscosity, prevent or reduce clogging of the filters and increase filtration rates. If **LiquiSEB** was used during the mash, **ClariSEB** enzyme could be used to clarify the product and to further reduce viscosity.
- **LiquiSEB** can also be used when the tanks are cleaned to help unclog filters
- The final juice is then filtered and bottled and labeled to go out to the consumer

www.rtg.wa.edu.au/ideas/kitchen/enzymes/enzymes.htm

Apple Juice

Enzymatic juice extraction from apples was introduced 35 years ago and today some 5 million tons of apples are processed into juice annually throughout the world.

Where enzymes are used in commercial production, juice is extracted as follows:

After they have been crushed, apples are usually left for 20–30 minutes so that

enzyme inhibitors in the pulp are oxidised. The pulp is then heated to 30 °C before

pectinases are added (this compares with a temperature of 50–60 °C

which is needed if enzymes are not used). Typically, 130 mL of enzyme is added for

every ton of apples. Enzyme treatment takes anything from 15 minutes to 2 hours,

depending upon the exact nature of the enzyme, the dosage rate, the reaction

temperature and the variety of apple used. Some varieties, like *Golden Delicious*, are

very difficult to break down. During incubation, the pectinases degrade soluble

pectin in the pulp, making the juice flow more freely

www.eurovolvox.org/Protocols/PDFs/AppleJuice03_UK_eng.pdf

Food pH

Product	Approximate pH
Apples	3.3 - 3.9
Bananas	4.5 - 5.2
Blackberries	3.9 - 4.5
Grapes	3.5 - 4.5
Lemons	2.2 - 2.4
Lemon juice	2.0 - 2.6
Mango	5.8-6.0

Pectinase breaks down pectin best at over a narrow pH range. This is the optimum pH. This can be a problem as a large number of fruit juices have a lower pH than the optimum pH for most pectinases. Special pectinases can therefore be made from fungi which will work even at a lower pH. This is essential if manufacturers are to be able to extract the most acidic juices such as lemon

www.engineeringtoolbox.com/food-ph-d_403.html

Useful Enzymes

Pectinase is an enzyme that breaks down the pectin in the connections between the cellulose in the cell walls of plants. This causes the release of juice.

My hypothesis is that at low temperatures the rate of reaction is slow as the temperature increases up to 30 °C the enzyme has more kinetic energy and more successful collisions occur so the rate of enzyme activity increases but above 45 °C the rate of activity decreases as the enzyme starts to be denatured. Therefore more juice is collected at 30°C than at 60°C as most of the enzyme has been denatured at 60°C.

Plan

Three apples of the same type are peeled and cored, they are then grated into a large beaker. This increases the surface area of apple to be exposed to the pectinase. The peel is removed as it does not contain juice, the core is removed as it will contain less juice than other parts of the apple. The grated apple is covered so they do not dry up.

14 boiling tubes are prepared, 7 labelled A and 7 E with a permanent marker. 10 grams of the apple are put in the boiling tube A using a spatula and 10 cm³ of 1% pectinase solution in those labelled E using a 10 cm³ syringe.

Seven water baths (beakers) are set up for the range of temperatures 30, 35, 40, 45, 50, 55, and 60 °C. Into each water bath one tube A and one E are added. They are left 5 minutes to adjust to the temperature.

The tubes are mixed and then stirred for 15 seconds using a glass rod to ensure the pectinase comes into contact with more apple. They are then left in the water baths for 15 minutes. The water baths temperature is checked regularly using a thermometer and hot water added to correct the temperature if needed.

After 15 minutes the contents of the boiling tubes are filtered into separate 25 cm³ measuring cylinder. The volume of juice collected every minute is recorded for 5 minutes. (They are left for 5 minutes to make sure all the juice is collected.) A 100g weight is placed on top of the apple to press it down to increase the amount of juice collected.

The volume of the enzyme solution is then taken from the volume of juice to give the final volume of juice.

Safety

It is obvious the apple should not be eaten. The main risk is that the Enzymes can cause allergic responses so hands should be washed and goggles worn. All spillages must be wiped up using a paper towel and plastic gloves to ensure no enzyme solution could contact the skin.

The main changes made to the plan is that we were given the apple which had been blended we did not grate it up. Blending will provide an even greater area for the pectinase enzyme to come into contact with the apple. The rate of collecting the juice per minute is not measured as the juice

comes out more rapidly at the start and will mainly consist of mainly the enzyme solution, it was therefore decided to use the final volume collected in 5 minutes.

Results

Volume of Apple Juice in cm³ collected in 5 minutes

Temperature °C	Volume enzyme cm ³	A cm ³	B cm ³	C cm ³	Average cm ³
30.0	10	5.5	6.0		5.75
35.0	10	6.5	6.5		6.50
40.0	10	7.0	7.5		7.25
45.0	10	7.0	7.5		7.25
50.0	10	6.0	6.5		6.25
55.0	10	4.5	5.0		4.75
60.0	10	3.5	2.0	3.0	3.25

The 60°C result was repeated as there was a big difference in values.

Useful enzymes

Enzymes such as pectinase can be used to speed up the breakdown of larger molecules into simple sugars. This makes the fruit softer and juicier. A fruit juice company uses a variety of different treatments and enzymes to increase the amount of juice produced.

- 1 Process the data you have collected and plot a graph of the results of your investigation into the effect of temperature on the activity of pectinase.
- 2 Describe any patterns or trends in your results. Comment on any unexpected results.

The results indicate that as the temperature increases from 30 °C to 40 °C the rate at which the pectinase activity increases as more juice is produced. The maximum rate is between 40°C and 45 °C after this the rate of enzyme action decreases. The graph indicates that the optimum temperature is 42.5 °C. From 45 °C to 60 °C the rate of reaction decreases as the amount of juice produced decreases. The amount of juice produced is lowest at 60 °C The results are close to the line of best fit and the only anomaly was at 60 °C where only 2 cm³ of juice was collected but we repeated this and the new volume collected was close to the first experiment

- 3 Compare the different treatments and enzymes used by fruit juice companies from your research (Part 1) with your own investigation (Part 2).

Comment on any similarities and differences. Suggest possible reasons for any differences.

The commercial process involves:

a) Juice extraction .

We peeled our fruit and cored as in the industrial process. We used a blender rather than press the apple as in the industrial process. Enzymes are then added both pectinase to break down the pectins in the connections between the cells and cellulase to breakdown the cellulose in the cell walls and release the juice for the Industrial process our experiment we only used pectinase.

The temperatures used by industry is 30°C as this is more suitable for the enzymes used industrially and use less energy to increase the temperature.

2

The amount of juice produced in our experiment at 30°C was still high only 1.5cm³ less than the maximum at 40°C.

b) Filtration.

We used filter paper where as the commercial process uses muslin or stainless steel filters. The material is pressed through the filters.

c) Preparation.

The fruit juice is then prepared for selling and it is pasteurised to kill microbes and denature the enzymes. Preservatives are added and extra sugar may be added. We did not do any preparation as the fruit juice was not for drinking or keeping..

4  Evaluate your results, the method you used and how well you managed the risks.

For temperature we took two sets of results. The volumes collected were within 0.5 cm³ for all temperatures accept 60°C, but when the experiment was repeated the new value was within 0.5cm³. The line of best fit was very close to the experimental values and well within the range bars. The result at 60°C could have been caused by the apple being broken down by the temperature as my research indicated that temperatures above 55°C are used to break down the apple if enzymes are not used. One of the main problems with the method was that the water baths were cooling down and although we kept checking them and adding hot water to keep the temperature right, they could only be kept at + or - 1 °C. It is likely that the enzyme solution and apple were at a lower temperature than required, this would have made only a small difference with temperatures of water baths below 40°C producing slightly less juice (but at levels unlikely to be detected) and those above 45°C producing slightly more juice. Also some of the juice was absorbed by the filter paper but this should be the same for each temperature. The thermometer was able to give a temperature reading accurate to 0.5 °C. The volume of enzyme solution was measured to 0.2cm³ using a syringe. There was a problem measuring the amount of apple added as we had to use a spatula but we placed the boiling tube in a beaker on a balance Another problem was when we poured the mixture into the filter not all of the mixture was removed from the boiling tube. Finally the pH of the apple might not have been at the optimum for the pectinase.

- 5 Do your results from Part 2 support the hypothesis you suggested? Explain your answer.

The results collected support my hypothesis. As the temperature increases the rate of enzyme action increases, as the enzymes have more kinetic energy and make more successful collisions with the apples pectin causing the cells to break down and releasing more juice from the cells. Above 45°C some of the enzyme is denatured so it can no longer break the apple cells down. As the temperature increase more enzyme is denatured so the rate of enzyme activity is reduced and less juice is released.

- 6 The company would need different treatments and enzymes to make different types of juice, for example lemon juice and mango juice.

Suggest why, using your knowledge of enzymes, information from your research (Part 1) and your investigation (Part 2).

The temperature used will be 30°C which from our experiment would still give a high yield of juice even though in our experiment less juice would be produced than at 40°C and the optimum is 42.5 °C. The enzymes used are fungal and the optimum temperature for industrial enzymes maybe nearer 30°C.

The pH of lemon is very acid (2.2-2.6) whereas the pH of mango is less acid (5.8-6.0) this means different types of pectinase would have to be used so they are able to work at the optimum pH, as the pectinase used for apples has an optimum pH of 3.3-3.8.

These values come from my research. Enzymes will be denatured if they are outside there pH range and work less if they are not at the optimum pH.

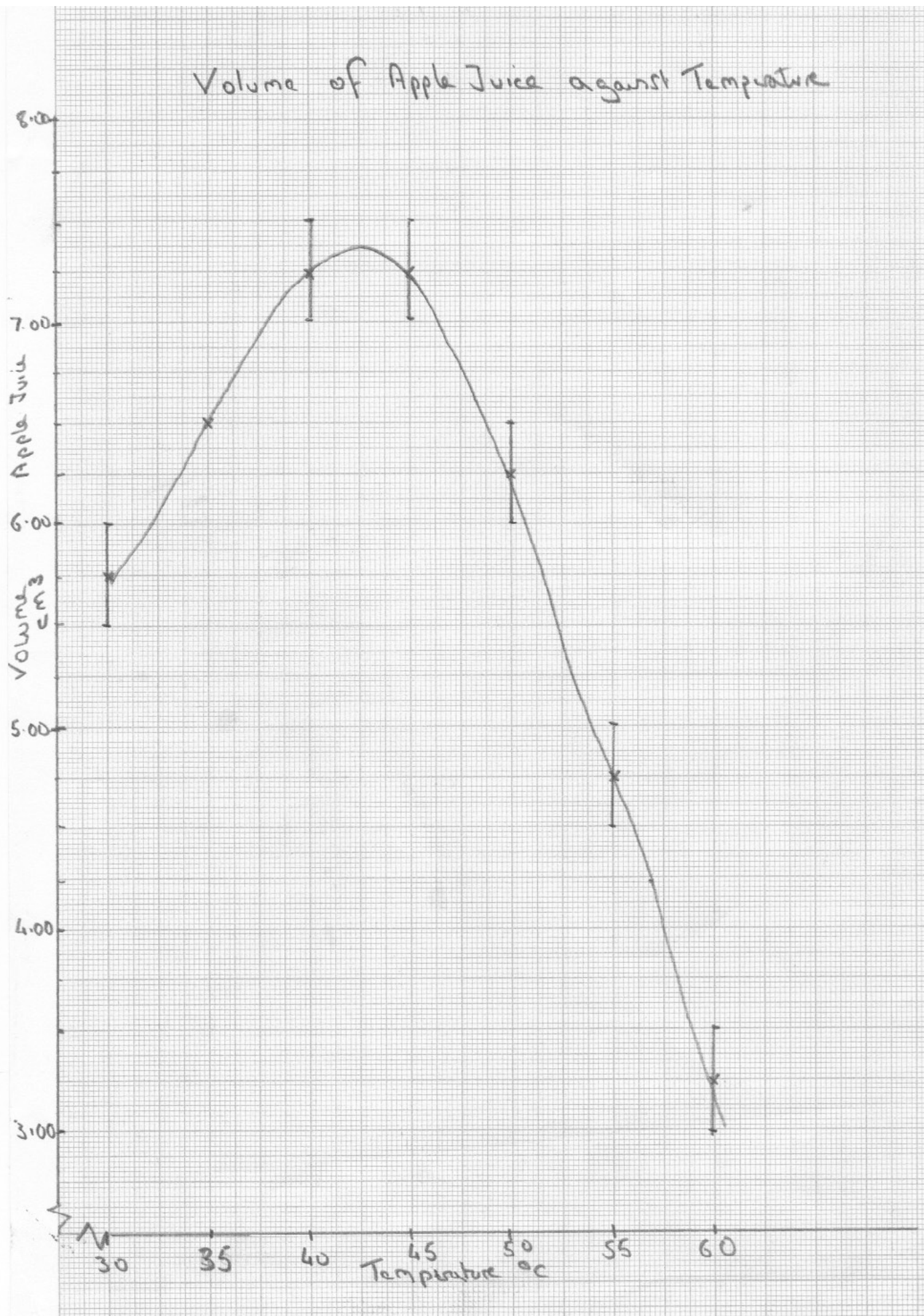

COMMENTARY FOR CANDIDATE C

Quality	Level L, M or H	Mark	Comments
Researching	H	6	Research referenced and relevant from a number of sources Q6 and Q3 answered correctly.
Planning	H	5	Not quite 6. Not enough on control of variables and elimination of errors. QWC OK.
Collecting data	M	4	Raw data not shown only final volumes. Average given to too many decimal points.
Managing risk	M	4	Some specific risks mentioned in the plan but not followed up in Q4.
Processing data	H	5	Variation in rate is discussed but rate is not calculated. Graph is excellent but not quite 6.
Analysing & interpreting	H	6	Process is compared. Patterns are correctly described. (denaturing is in Q5)
Evaluating	M	4	QWC good as is treatment of data and error sources BUT no suggested improvements.
Conclusion	M	4	Correct science, hypothesis justified but data not really used.
	Total	38	

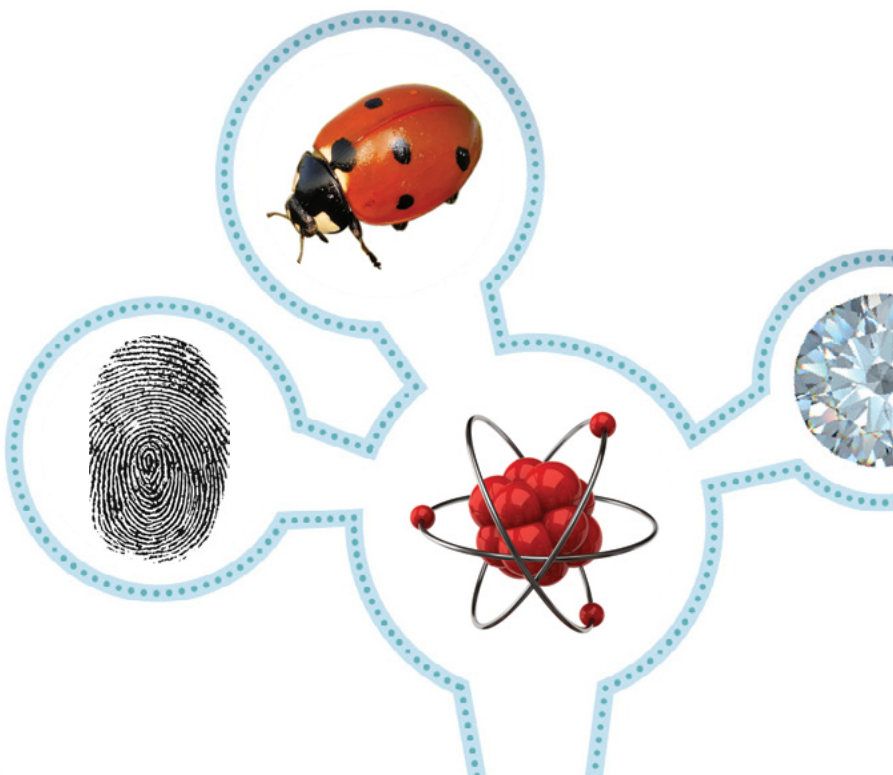

BIOLOGY CANDIDATE D

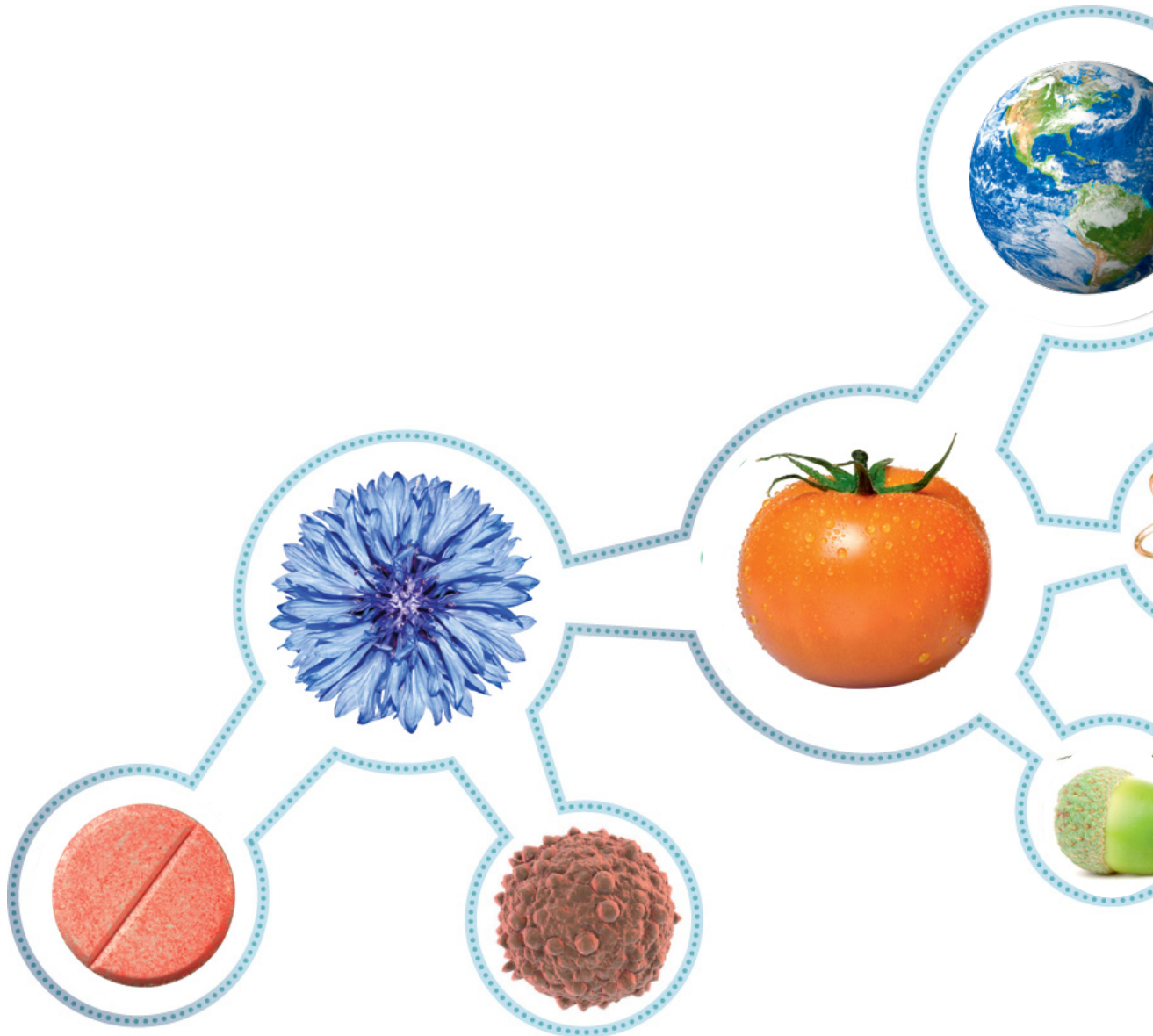

Sources

Enzymes Wikipedia

Fruit Juice processing

Enzyme

[Edit](#)

- [History](#)

An **enzyme** is a *protein* that acts as a biological *catalyst*. Enzymes are found in living organisms, where they speed up [metabolic reactions](#). Every different metabolic reaction needs a different enzyme to catalyse it. Therefore, a living organism needs thousands of different types of enzyme.

Enzymes have a dent in them, called the active site. The substances which are in the reaction [fit](#) exactly in this dent.

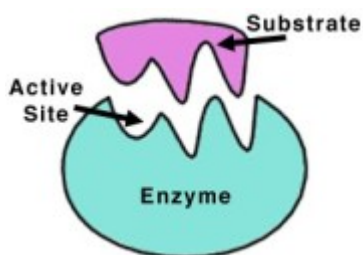

The Reaction between an enzyme and a substance

Added by [Someone.very.cool](#)

Contents

[\[show\]](#)

-

Edit Some different types of enzyme

- Amylase: breaks starch down into maltose
- Maltase: breaks down maltose into glucose
- Catalase: breaks down hydrogen peroxide to hydrogen and oxygen.
- Lipase: breaks fats into fatty acids and glycerol
- Pepsin: breaks proteins into smaller polypeptides
- Trypsin: also breaks down proteins to form polypeptides
- Protease: breaks smaller polypeptides down into amino acids
- Pectinase: breaks down cell walls
- Lactase: breaks down sugar (lactose) into glucose and galactose

Edit The effect of heat on enzymes

If enzymes are heated, the reaction can be sped up, or the enzyme will lose its shape. Because of this, the active site also loses shape - therefore the substances will not fit into it. The enzyme is **denatured**. If they are cooled, the rate of reaction slows. Enzymes in our body usually work fastest at around 37C.

Edit The effect of pH on enzymes

Enzyme molecules only work within a narrow pH - if the pH is outside this, they are denatured - the shape of their active site is changed - and do not work. This is not the same as dying. They are not technically living as they do not perform all life processes. Different enzymes work best at different pHs for example, enzymes working in the intestine work best at around pH 7, whereas, enzymes working in the stomach work best at around pH 2.

Edit Enzymes in industry:)

Edit Washing powders

Washing powders contain detergents in them to help remove grease and dirt from clothes. These help the grease dissolve in water. After this, it is washed off. However, some stains are not greasy and therefore detergents will not work on these. To help remove these stains, enzymes can be used - in biological washing powders. These sometimes contain proteases which break down proteins (e.g. from an egg) into amino acids, which can then be washed off more easily.

Edit Food

Enzymes are used greatly in the food industry, for example pectinase is used to make it easier to squeeze lots of juice out of apples, and to turn the cloudy apple juice into the preferable clear liquid most people prefer. Lactase is also used to break down lactose in milk, as many people cannot digest this sugar. The lactose breaks down into galactose and glucose.

gcse.wikia.com/wiki/Enzyme

Fruit Juice Processing

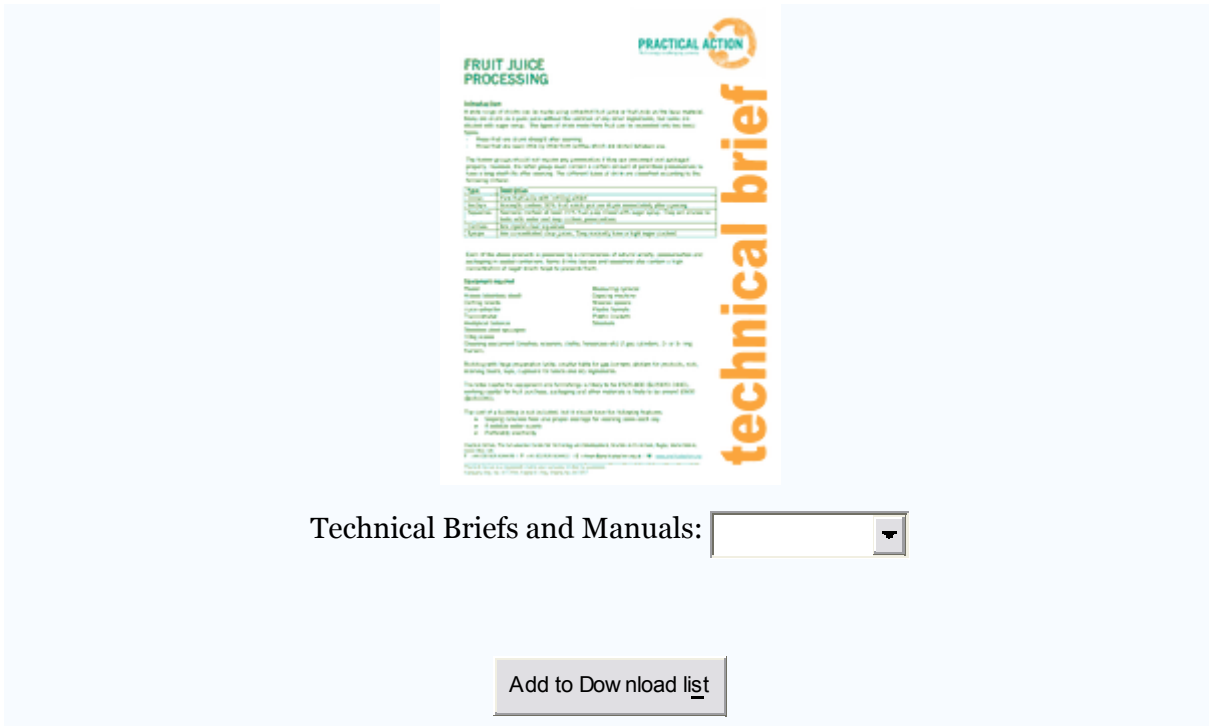

Technical Briefs and Manuals:

Add to Download list

This is a text-only version of the Technical Brief. For the full version, with illustrations, please download the free printable PDF document. To read the PDF, you will need the current version of Adobe Acrobat reader, which can be downloaded free from [Adobe's website](http://adobe.com).

Introduction

A wide range of drinks can be made using extracted fruit juice or fruit pulp as the base material. Many are drunk as a pure juice without the addition of any other ingredients, but some are diluted with sugar syrup. The types of drink made from fruit can be separated into two basic types;

- those that are drunk straight after opening
- those that are used little by little from bottles which are stored between use.

The former groups should not require any preservative if they are processed and packaged properly. However, the latter group must contain a certain amount of permitted preservatives to have a long shelf-life after opening. The different types of drink are classified according to the following criteria:

Type	Description
Juices	Pure fruit juice with nothing added
Nectars	Normally contain 30% fruit solids and are drunk immediately after opening

Squashes	Normally contain at least 25% fruit pulp mixed with sugar syrup. They are diluted to taste with water and may contain preservatives
Cordials	Are crystal-clear squashes
Syrups	Are concentrated clear juices. They normally have a high sugar content

Each of the above products is preserved by a combination of natural acidity, pasteurisation and packaging in sealed containers. Some drinks (syrups and squashes) also contain a high concentration of sugar which helps to preserve them.

Kiswahili

Uandaaji wa Vinywaji vya Matunda

Aina mbalimbali ya vinywaji vinaweza kutengenezwa kwa kutumia juisi ya matunda kama malighafi ya kimsingi. Vinywaji vingi hutumiwa kama juisi. Vinywaji vingi hutumiwa kama juisi mahususi bila ya kuongezwa viungo vingine, lakini baadhi huongezwa sukari. Aina ya vinywaji vinavyotengenezwa kutokana na matunda vinaweza kuwekwa katika makundi mawili makuu kimsingi:

Vile ambavyo vinaweza kutumiwa punde tu baada ya pakiti zao kufunguliwa.

Vile vinavyochoviwa kidogokidogo kutoka kwenye chupa na hatimaye kuhifadhiwa baada ya kutumiwa.

Kundi la kwanza halihitaji kiungo chochote cha kufanya vinywaji hivyo vidumu iwapo vimeandaliwa na kupakiwa vizuri.

Hata hivyo, kundi la pili la vinywaji lazima liwe na kiwango fulani cha kemikali kilichoruhusiwa kuvihifadhi ili vidumu iwapo vimeandaliwa na kupakiwa vizuri. Aina mbalimbali ya vinywaji huwekwa katika makundi kulingana na utaratibu ufuatao.

Equipment required

Peeler

Knives (stainless steel)

Cutting boards

Juice extractor

Thermometer

Analytical balance

Stainless steel saucepan

10kg scales
 Measuring cylinder
 Capping machine
 Wooden spoons
 Plastic funnels
 Plastic buckets
 Strainers

Cleaning equipment (brushes, scourers, cloths, hosepipes etc) 2 gas cylinders, 2- or 3-ring burners.

A **building** with large preparation table, smaller table for gas burners, shelves for products, sink, draining board, taps, cupboard for labels and dry ingredients.

The total capital for equipment and furnishings is likely to be £500 - 800 (\$US900-1440), working capital for fruit purchase, packaging and other materials is likely to be around £600 (\$US1080).

The cost of a building is not included, but it should have the following features:

Sloping concrete floor and proper drainage for washing down each day

A potable water supply

Preferably electricity

Screened windows and doors to reduce insects

No horizontal ledges, window sills, or rafters where dust, insects and bird droppings can collect.

This technical brief outlines the basics of fruit juice processing. It does not give specific details or recipes for individual fruits. These can be found in the individual technical briefs (lime cordial, mixed fruit juice manufacture, passion fruit juice).

Method of production

For all the fruit based beverages, the first stage is the extraction of juice or pulp from the fruit. The following are the key manufacturing stages:

Selection and preparation of raw material
 Juice extraction
 Filtration (optional)
 Batch preparation

Pasteurisation

Filling and bottling.

Any fruit can be used to make fruit juice, but the most common ones include pineapple, orange, grapefruit, mango and passion fruit. Some juices, such as guava juice, are not filtered after extraction and are sold as fruit nectars.

Preparation of raw material

Select mature, undamaged fruits. Any fruits that are mouldy or under-ripe should be sorted and removed. Wash the fruit in clean water. It may be necessary to chlorinate the water by adding 1 tablespoon of bleach to 5 litres of water. Peel the fruit and remove stones or seeds. If necessary, chop the fruit into pieces that will fit into the liquidiser or pulper. Remember that at this stage, you are exposing the clean flesh of the fruit to the external environment. Make sure that the utensils are clean. Do not leave the cut surfaces exposed to the air for long periods of time or they may start to turn brown and this will discolour the juice. The fruit pieces can be placed in water that contains lemon juice (250ml lemon juice per litre of water) to stop them browning.

Figure 1: Hand presser. Download the full PDF version to see this picture.

Juice extraction

There are several methods to extract juice depending on the type of fruit you use. For citrus fruits which are naturally juicy, the best option is to use a hand presser (see figure 1) or a revolving citrus 'rose'. Some fruits such as melon and papaya are steamed to release the juice. Apples are pressed and fruits such as mango, guava, soursop, pineapple, strawberry must be pulped to extract the juice. The fruit pieces are pushed through a perforated metal plate that crushes and turns them into a pulp. Some fruits can be pulped in a liquidiser and then filtered to remove the fruit pieces. There is a range of equipment available that varies in size and in the type of power supply (some are manual while the larger ones require electricity). For the small scale processor, the Mouli Legume or a hand-powered pulper/sieve which force the fruit pulp down through interchangeable metal strainers (figures 2 and 3) is sufficient.

At slightly higher production levels, it is necessary to use a power source to achieve a higher throughput of juice. The multi-purpose Kenwood Chef food mixer, is strongly recommended. This has a pulping attachment that is similar to the Mouli Legume and it can also be used for other operations such as liquidising and mixing.

Figure 2: Hand powered pulper. Download the full PDF version to see this picture.

Figure 3: Hand powered pulper. Download the full PDF version to see this picture.

For large-scale production, an industrial pulper-sieving machine is necessary. This also acts by forcing the fruit pulp through a fine cylindrical mesh. However, these cost in excess of £2,500.

Filtering

To make a clear juice, the extracted juice or pulp is filtered through a muslin cloth or a stainless steel filter. Some of the larger filter presses have a filter included. Although juice is naturally cloudy, some consumers prefer a clear product. It may be necessary to use pectic enzymes to break down the pectin and to help clear the juice. Pectic enzymes may be difficult to find and expensive and therefore should only be used if really necessary and readily available.

Batch preparation

When the juice or pulp has been collected, it is necessary to prepare the batch according to the chosen recipe. This is very much a matter of choice and judgement, and must be done carefully to suit local tastes. Juices are sold either pure or sweetened. Fruit squashes would normally contain about 25% fruit material mixed with a sugar syrup to give a final sugar concentration of about 40%. Squashes are diluted with water prior to use and, as the bottle is opened, partly used and then stored, it is necessary to add a preservative (for example 800ppm sodium benzoate).

Another popular product is fruit nectar, which is a sweet mixture of fruit pulp, sugar and water which is consumed on a 'one shot' basis. Essentially, these consist of a 30% mix of fruit pulp and sugar syrup to give a final sugar level of about 12-14%.

All fruits contain sugar, usually around 8-10%. The actual levels vary from fruit to fruit and with the stage of ripeness of the fruit. They also vary within the same fruit grown in different parts of the world. The addition of sugar to the fruit pulp to achieve the recommended levels for preservation must take into account the amount of sugar already present in the juice. It is important to achieve the minimum level that will prevent the growth of bacteria, however, once that level has been achieved, it is possible to add more if the consumers require a sweeter product. The amount of sugar added in practice is usually decided by what the purchasers actually want. The Pearson Square is a useful tool to use to help with batch formulation (see the appendix) and to calculate the amount of sugar to be added for preservation.

In all cases, sugar should be added to the fruit juice as a sugar syrup. The syrup should be filtered through a muslin cloth prior to mixing to remove particles of dirt which are always present. This gives a clearer, higher quality product.

Pasteurisation

All the products mentioned above need to be pasteurised at 80-95°C for 1-10 minutes prior to hot-filling into bottles. At the simplest level, this may be carried out in a stainless steel, enamelled or aluminium saucepan over a gas flame, but this can result in localised overheating at the base of the pan, with consequent flavour changes.

Care is needed when producing pineapple juice due to a heat resistant enzyme in the juice. The enzyme damages skin after prolonged contact and workers should therefore wear gloves to protect their hands. The juice must be heated to a higher temperature for a longer time to destroy the enzyme (eg boiling for 20 minutes).

It is best to use stainless steel pans to heat fruit juice as the acidity of the juice can react with aluminium in aluminium pans during prolonged heating. However, large stainless steel pans are very expensive and may not be affordable by the small scale processors. To get round this problem, it is possible to use a large aluminium pan to boil the sugar syrup. The boiling syrup can then be added to a given amount of fruit juice in a small stainless steel pan. This increases the temperature of the juice to 60-70°C. The juice/syrup mixture is then quickly heated to pasteurising temperature.

Bottle size (litres)	Pasteurisation time at 80°C (minutes)
0.33	10
0.5	15
0.75	20

Table 1. Pasteurisation times at 80°C for different bottle sizes.

Another option is to pasteurise the juices once they have been bottled. The bottles are placed in a hot water bath which is heated to 80°C. The bottles are held in the hot water for the given amount of time until the contents reach the desired

temperature. The length of time required in the water bath depends on the size and volume of the bottles (see table 1). A thermometer should be placed in one of the bottles, which is used as a test bottle per batch, to monitor the temperature and to ensure that the correct temperature has been reached. This method of pasteurisation has benefits but also has problems.

Benefits	Problems
Juice is pasteurised within the bottle so the chance for re-contamination of the juice is reduced	Difficult to ensure the internal temperature of the bottles reaches the desired pasteurising temperature
No need for large stainless steel pans for pasteurisation	Require glass bottles for pasteurising

Table 2. The pros and cons of pasteurising within after bottling

The next industrial jump in pasteurisation is an expensive option that involves the purchase of a double-jacketed steam kettle in stainless steel and a small boiler. The total cost is likely to be in the region of £5-10,000, which is only viable for larger scale operations.

Filling and bottling

In all cases, the products should be hot-filled into clean, sterilised bottles. A stainless steel bucket, drilled to accept a small outlet tap, is a very effective bottle filler. The output can be doubled quite simply by fitting a second tap on the other side of the bucket. This system has been used to produce 500-600 bottles of fruit juice per day in the West Indies.

After filling hot, the bottles are capped and laid on their sides to cool prior to labelling.

Quality control

The freshness and quality of the expressed fruit juice is central to the quality of the final product. As soon as the juice is expressed from the fruit it starts to deteriorate, both as a result of chemical activity (enzyme action) and bacterial spoilage. It is important to move from the juice extraction stage to pasteurisation as quickly as possible to minimise any spoilage.

Extracted fruit juice that is left to stand for long periods in the heat will start to ferment and may start to discolour due to enzyme activity. The juice should be stored in a refrigerator (if one is available) or in a cool place and away from the direct sunlight. It should be collected into a clean, sterile container (food grade plastic buckets is the best option) and covered to keep out dirt, dust and insects. For the best quality product, it is essential to work quickly between the extraction of the juice and the bottling stage. The longer the juice is out of the bottles, the more chance there is of contamination.

As in all food processing enterprises it is necessary to ensure that the fruit products are correctly formulated and priced to meet the customer's requirements, and that production costs are minimised to ensure that a profit is made. The quality of each day's production should be monitored and controlled to ensure that every bottle of juice has the correct keeping and drinking qualities. In particular the following points should be observed:

- Only fresh, fully ripe fruit should be used; mouldy or insect damaged fruit should be thrown away. All unwanted parts (dirt, skins, stones etc) should be removed.
- All equipment, surfaces and floors should be thoroughly cleaned after each day's production.

- Water quality is critical. If in doubt use boiled water or add one tablespoon of bleach to 5 litres of water to sterilise it. If water is cloudy, a water filter should be used.
- Pay particular attention to the quality of re-usable bottles, check for cracks, chips etc and wash thoroughly before using. Always use new caps or lids.
- The concentration of preservative should be carefully controlled for correct preservation of squashes and cordials, and may be subject to local laws. Check first and use accurate scales to measure the preservative.
- The temperature and time of heating are critical for achieving both the correct shelf life of the drink and retaining a good colour and flavour. A thermometer and clock are therefore needed.
- The correct weight should be filled into the bottles each time.

These factors are important because a customer will stop buying the products if the quality varies with each purchase.

The use of chemical preservatives in fruit juices and fruit drinks

As the name suggests, pure fruit juice is solely the extracted juice of fruit and should not have any preservative, or any other ingredients (such as sugar) added.

Fruit drinks that are not consumed in one go can have preservatives added to help prolong the shelf life once they have been opened.

There are several chemical preservatives that can be added to fruit juices. Processors need to check with local authorities or standards agencies to find the maximum permitted levels.

Compound	Comments	Commonly used levels
Sulphites and sulphur dioxide	Sulphur dioxide gas and the sodium or potassium salts of sulphite, bisulphite or metabisulphite are the most commonly used forms. Sulphurous acid inhibits yeasts, moulds and bacteria. Sulphur dioxide is mainly used to preserve the colour of fruits during drying.	0.005-0.2%
Sorbic acid	Sorbic acid and sodium and potassium sorbate are widely used to inhibit the growth of moulds and yeasts. The activity of sorbic acid increases as the pH decreases. Sorbic acid and its salts are practically tasteless and odourless in foods when used at levels less than 0.3%.	0.05-0.2
Benzoic acid	Benzoic acid, in the form of sodium benzoate is a widely used preservative. It occurs naturally in cranberries, cinnamon and cloves and is well suited for used in acid foods. It is often used in combination with sorbic acid at levels from 0.05-0.1% by weight.	0.03-0.2%
Citric acid	Citric acid is the main acid found naturally in citrus fruits. It is widely used in carbonated beverages and as an acidifier of foods. It is a less effective anti-microbial agent than other acids.	

Useful Enzymes

My hypothesis is that enzymes work best at body temperature 40 C, they do not work at high temperatures.

Apparatus

Boiling tube, razor, enzyme, measuring cylinder, thermometer, stopwatch, apple

Plan

1. I will cut an apple into small squares using a razor blade.
2. I will put 5 pieces into 6 boiling tubes.
3. I will add 5mls of the enzyme to each boiling tube.
4. Then I will add two to a beaker of water at 30C, 40C and 60C.
5. I will leave the tubes for 15-20 minutes.
6. I will filter the tubes into a cylinder.
7. I will read the amount of juice there is.

Safety

I must not eat the apples. I must not cut my fingers with the blade.

Results

Temperature	Volume of juice	Average
30 C	7 mls	
30 C	7mls	7
40 C	8 mls	
40 C	8 mls	8
60 C	6 mls	
60 C	6 mls	6

Useful enzymes

Enzymes such as pectinase can be used to speed up the breakdown of larger molecules into simple sugars. This makes the fruit softer and juicier. A fruit juice company uses a variety of different treatments and enzymes to increase the amount of juice produced.

- 1 Process the data you have collected and plot a graph of the results of your investigation into the effect of temperature on the activity of pectinase.

- 2 Describe any patterns or trends in your results. Comment on any unexpected results.

As the temperature goes up the amount of juice goes up then it goes down.

The results for 60 C are wrong as no juice should be produced as the enzyme should be destroyed,

- 3 Compare the different treatments and enzymes used by fruit juice companies from your research (Part 1) with your own investigation (Part 2).

Comment on any similarities and differences. Suggest possible reasons for any differences.

Fruit companees seem to pulp the fruit which I didn't and heat it at the end to kill the germs and enzymes which we didn't. We both used enzymes but they used some different ones to clear the fruit juice. They also used far more fruit.

- 4  Evaluate your results, the method you used and how well you managed the risks.

My results were good. They are reliable as I carried them out twice at each temperature also they matched the line I drew. They are accurat as I used a ruler, thermometer and measureing cilinder. I had difficulty cutting the apple to the right length. I think I should have removed the skin from the apple. I should have checked the water baths kept hot as they did not. Maybe this is why it worked at 60C. I was very safe with the rasor blade and did not eat any apple.

2

- 5 Do your results from Part 2 support the hypothesis you suggested? Explain your answer.

My results match my hypothesis as the enzyme worked best at body temperature.

There was more juice made at 30 C then 60 C as the task said, so my results matched this

- 6 The company would need different treatments and enzymes to make different types of juice, for example lemon juice and mango juice.

Suggest why, using your knowledge of enzymes, information from your research (Part 1) and your investigation (Part 2).

The enzyme works on apple. Enzymes only work on one type of fruit so they would not work on Mango or lemon. People do not drink mango juice. Lemons have a thicker peel so would need peeling. It would have to be done at 30C as that is what the experiment is done at. 30. I would squeeze the lemon as it is very juicy. and not add enzymes

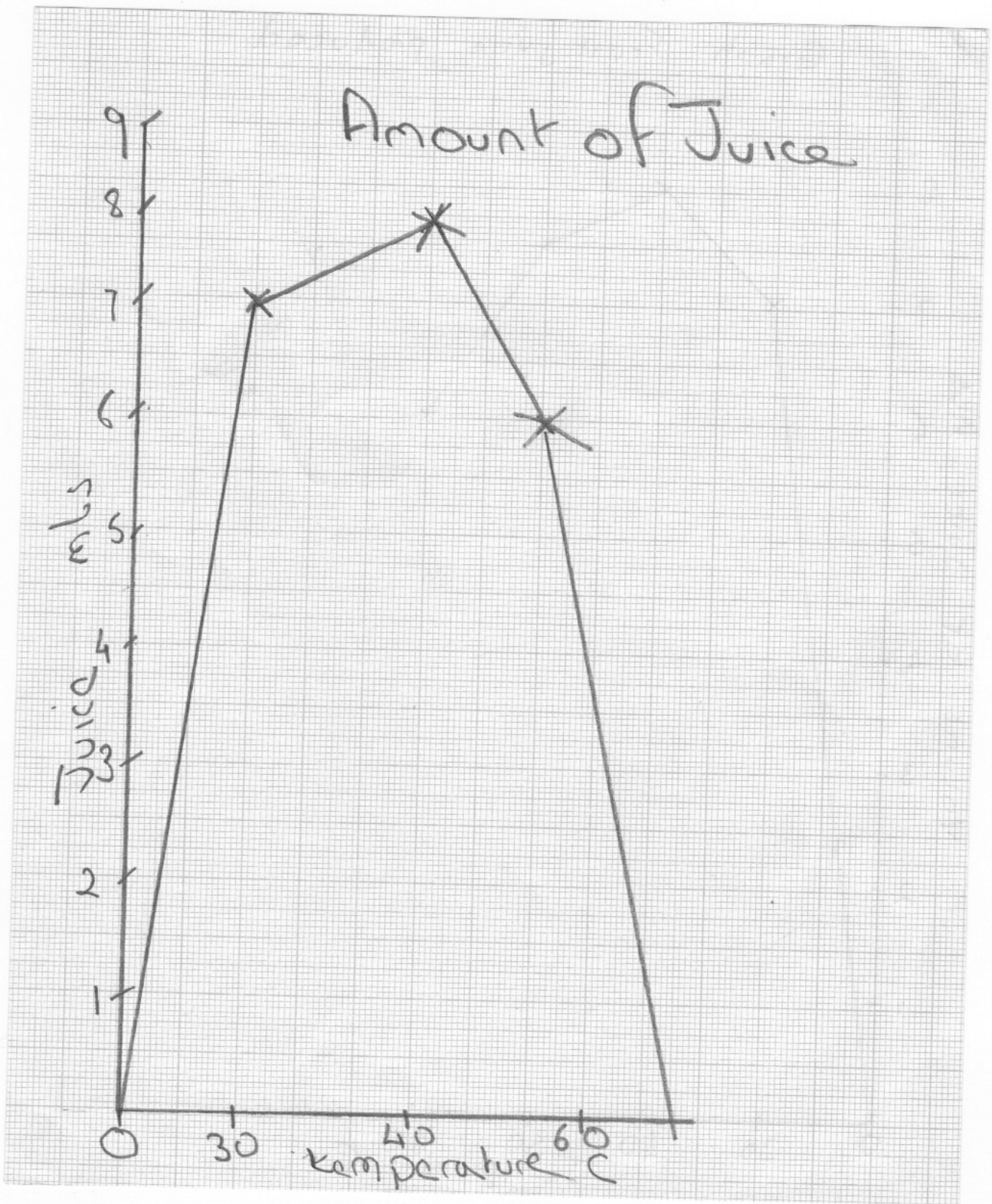

COMMENTARY FOR CANDIDATE D

Quality	Level L, M or H	Mark	Comments
Researching	L	2	Some information found. No real references. Much of the information is not relevant.
Planning	L	2	Not a real hypothesis more a prediction. Low level plan. No timings or repeats. QWC low level.
Collecting data	M	3	Nearly a table. Volumes, temperatures and averages shown.
Managing risk	M	4	Some specific risks are mentioned in the plan and commented on in the evaluation.
Processing data	L	2	Graph is dot to dot. Origin is wrongly included and 'x' scale wrong. No real calculations (averages of identical values).
Analysing & interpreting	L	2	Simple pattern. Mistakes in explanation (optimum). Comparison with research/commercial is irrelevant.
Evaluating	L	2	OK for 2. Correct comment on technique but comment re 60°C is wrong.
Conclusion	L	2	Correct but no science, basic conclusion only.
	Total	19	

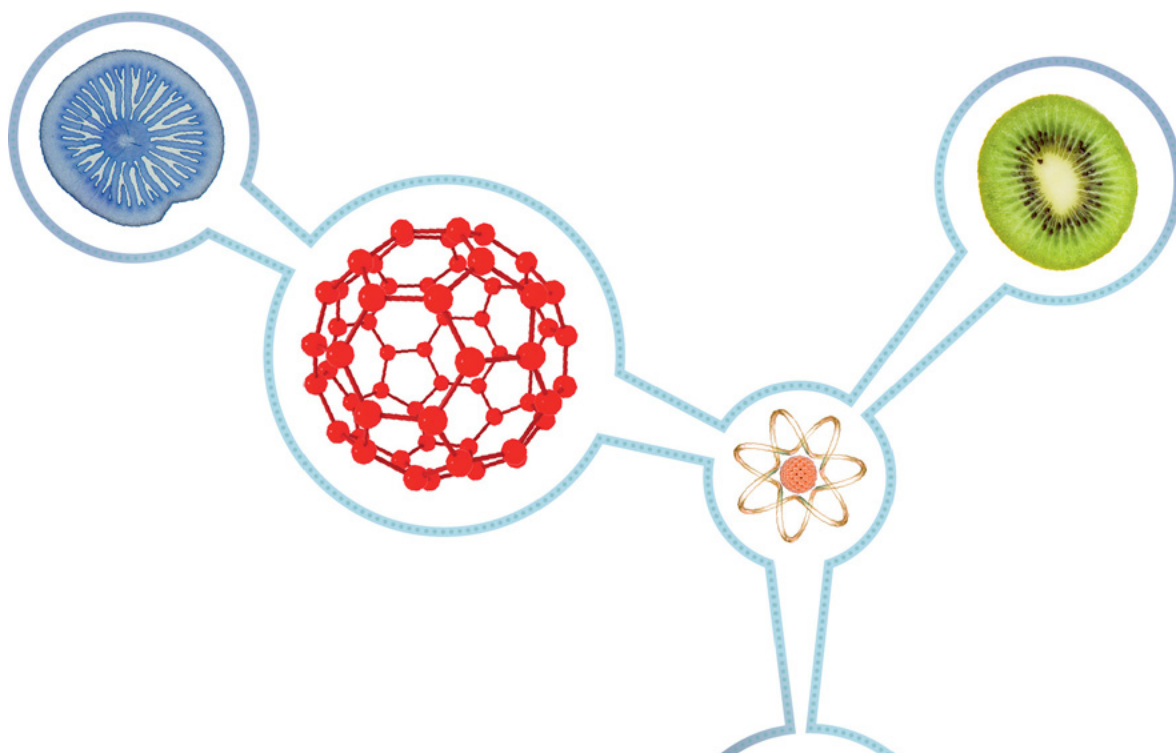

CHEMISTRY CANDIDATE E

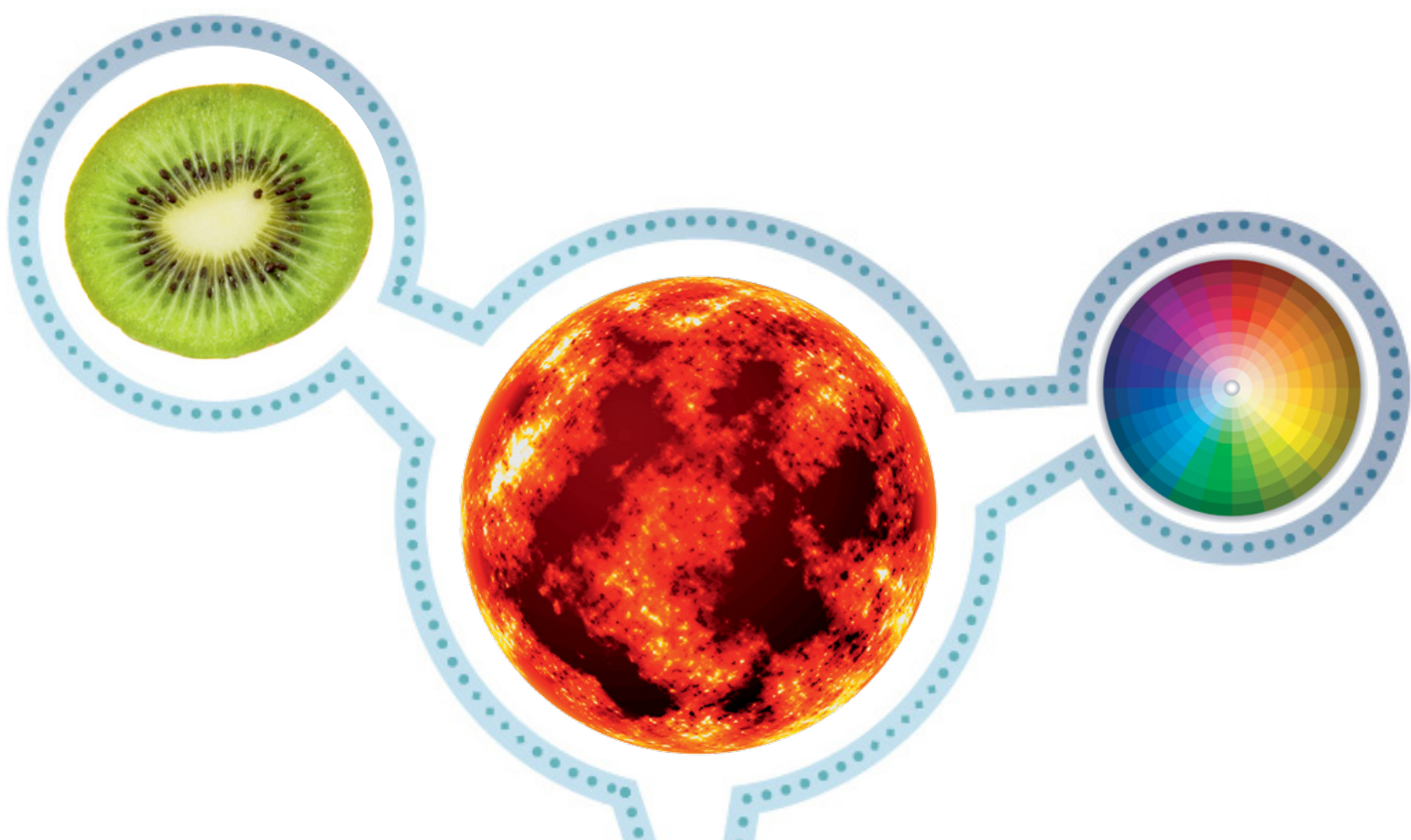

Green Transport

Part 1: Research

Crude oil is one of the world's fossil fuels that have been used at an ever-increasing rate over the last hundred years. Almost all transport now uses fuels derived from crude oil to power vehicles (cars, lorries, ships, trains and planes) but there are two problems about this.

The first is that crude oil is a finite resource and research shows that most of it will be exhausted in the next forty years. (www.independent.co.uk/news/science/world-oil-supplies-are-set-to-run-out-faster-than-expected-warn-scientists-453068.html)

The other is that because the fuels are mainly hydrocarbons there is an increasing amount of carbon dioxide being pumped out into the atmosphere and this is causing global warming. "...there is a simple linear relationship between total cumulative emissions and global temperature change." (www.sciencedaily.com/releases/2009/06/090610154453.htm)

Alternative fuels are needed and the best alternative fuels are 'carbon-free' ones. Another solution is to produce hydrocarbon fuels from alternative sources such as plants and algae.

I found the following list of alternative fuels from using the internet.

Bio-ethanol

The source material for the production of bio-ethanol is any carbohydrate. 'Corn' and sugar cane are two suitable sources being used commercially. The carbohydrate is fermented in a similar process for producing beer and the product is then distilled. The distillate is mixed with petrol and can be used directly in unconverted cars, but cars with converted engines can use the bio-ethanol directly. Brazil currently has 40% of its cars running on bio-ethanol. The production is claimed to be 'carbon-neutral' because the growing plants need carbon dioxide in photosynthesis and they take this from the atmosphere. The downside is that the plants take up land that is used to grow food crops so this is a dilemma. (www.shell.com/home/content/environment_society/alternative_energies_transport/biofuels/?gclid=CJLasralmqSCFZQOfAod82vzfw)

Bio-diesel

The source is an oil-seed crop such as rape that is chemically treated to produce the fuel. The oilseed is esterified using an economical, low pressure and low temperature process, which is 98% efficient. (www.esru.strath.ac.uk/EandE/Web_sites/02-03/biofuels/what_biodiesel.htm)

The old oil from fish-and-chip shops can also be used to make bio diesel. The bio diesel is cheap and can be used directly in ordinary diesel engines which do not need to be adapted.

As with bio-ethanol the oilseed rape plants take up valuable land, which would otherwise be used for food crops, but on the other hand they are 'carbon-neutral'.

Bio-gas

This is methane (CH₄) mixed with some carbon dioxide and is formed when sewage or other waste decomposes anaerobically. It can be made from twitch-grass; grown on waste land. A digester is used and the gas is stored in tanks on cars and HGV. (www.uk-energy-saving.com/biogas.html)

Hydrogen (H₂)

This can be generated from water using electricity. It has to be stored under high pressure in cylinders in cars. It is a 'clean' alternative fuel as it does not contain any carbon but the engines need to be converted to use it. "Integrated wind-to-hydrogen plants, using electrolysis of water, are exploring technologies to deliver costs low enough, and quantities great enough, to compete with traditional energy sources."(wikipedia.org/wiki/Hydrogen_vehicle). If the electricity needed is generated by hydroelectricity or by wind/tidal then it is really 'green', but if it comes from an ordinary fossil fuel power station then it isn't.

Compressed Natural Gas (CNG) is another fuel. It is a mixture of propane and butane. It is a lighter fraction from the distillation of crude oil so it isn't really a proper alternative fuel. (www.altfuels.org/backgrnd/altftype/cng.html) It is currently available for cars and HGV but needs to be stored in a cylinder.

Electricity

Electricity is not really a fuel but a source of energy. Electric cars have batteries and you plug them in at home to charge them up. These cars are slow and have only a limited range of about 30 miles. But they are available now and charging points are at various places. If the generation of the electricity is 'green' then this is proper 'clean alternative fuel that is carbon free'.

(www.nextgreencar.com/electric-cars/)

To compare the energy given off from different fuels I used a website:

(www.afdc.energy.gov/afdc/pdfs/afv_info.pdf)

which gave me a table.

I made a summary of this table.

Fuel	Structure	Energy content per gallon (BtU)	Energy ratio compared to petrol
Petrol	C ₄ to C ₁₂	109000 to 125000	-
Diesel	C ₁₀ to C ₂₀	128000 to 130000	-
Bio diesel	C ₄₆ to C ₆₀	117000 to 120000	90%
CNG	CH ₄	33000 to 44000 (under pressure)	25%
Electricity	-	-	-
Bio-ethanol	CH ₃ CH ₂ OH	80000	70%
Hydrogen	H ₂	6500 (under pressure)	-
Methanol	CH ₃ OH	56000 to 66000	57%

Not all the energy ratios were given but it seems that none of them give out as much energy as petrol but bio diesel seems to be the best of the alternatives.

Green Transport

Part 2: Planning and collecting primary data

The molecular formula of ethanol is C_2H_6O .
The molecular formula of biodiesel is $C_{19}H_{34}O_2$

When these fuels burn completely they will produce only carbon dioxide (CO_2) and water (H_2O). During combustion chemical bonds are broken (energy is needed for this - this is endothermic) and new chemical bonds are made (energy is given out for this – this is exothermic). The amount of energy needed to break the bonds is less than the amount of energy given out so the result is an exothermic reaction producing heat energy which is used in moving the cylinders in the car or train or lorry, or the turbine blades in a plane.

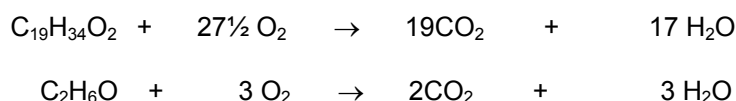

The following types of bond have to be broken: C – C C – H C – O O – H O=O
The following bonds have to be made C=O O – H

My hypothesis is that the more bonds which are broken/formed in a combustion reaction the more energy is released.

My plan

I will burn a series of fuels with different numbers of bonds and measure the energy released. I predict that the more bonds there are to break and reform the more energy will be released.

I will use a spirit burner, a black tin containing water, a thermometer, a tp balance and a timer.

The variables:

Controlled factors

- Distance between fuel and tin will be kept the same by using a stand to set the burner on
- Time that fuel is burnt for will be the time needed to raise the water by as close to $10^\circ C$
- Volume of water in tin will be $250cm^3$ (i.e 250g)
- Type of burner will be kept the same.

Independent variable

- This will be the different fuels

Dependent variable

- Temperature increase and the amount of fuel burnt will give energy released in kJ.

I will measure the temperature of the water at the start and the end. The amount of fuel burnt which will be found by finding the mass of the burner at the start and at the end.

I will record the results in 2 tables. One will be the actual one that is used during the experiment, which will have the working out for the mass burnt of the fuel and the temperature rise.

The other table will use the results but will also work out the energy released per mole.

My actual method

I will set up the apparatus below to carry out the experiment. I will light the burners with a splint and will use a black tin can, as they will absorb more of the heat energy so making a fairer test, as less will be lost. The water will be accurately measured out each time using a measuring cylinder, and simple tap water will be

used. The same measuring cylinder, scales to weigh burner and thermometer will be used throughout in the case of any inaccuracies, as at least then they will be consistent throughout. I will repeat the experiment to achieve more reliability and to prove the first set of results.

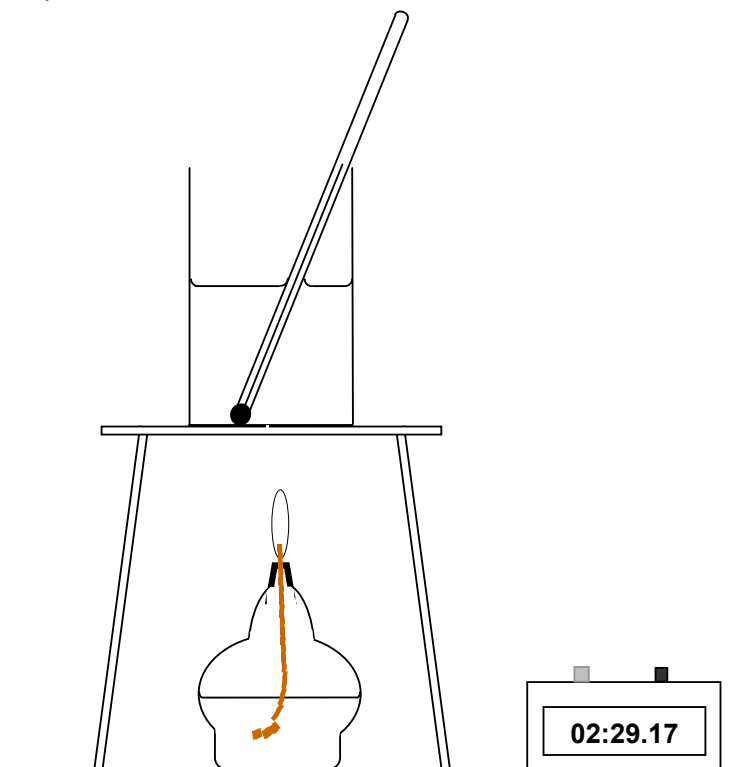

My primary data

Fuel	Initial mass (g)	Final mass (g)	Mass of alcohol burnt (g)	Initial temperature (°C)	Final temperature (°C)	Change in temperature (°C)
First set of results						
Methanol	177.14	175.66	1.48	20.6	30.8	10.2
Ethanol	211.32	209.28	2.04	20.8	30.8	10
Propanol	219.06	217.04	2.02	24.6	34.8	10.2
Butanol	231.18	229.2	0.98	22.8	33.4	10.6
Second set of results						
Methanol	174.94	173.74	1.2	22.4	33.4	11
Ethanol	237.5	235.14	2.36	24.2	34.4	10.2
Propanol	178.6	177.82	0.78	23.2	33.4	10.2
Butanol	232.96	231.92	1.04	20.6	30.8	10.2

To work out the energy released I will use this formula:

$$Q = mc\Delta T$$

M = mass of water

c = specific heat capacity of water = $4.2 \text{ KJ kg}^{-1} \text{ }^\circ\text{C}^{-1}$

ΔT = temperature change

	Molar Mass (g/mol)	Mass of alcohol burnt (g)	Moles of alcohol burnt	Temperature change ($^{\circ}\text{C}$)	Energy released (kJ)	Energy released per mole (kJ)
First set of results						
Methanol	32	1.28	0.046	10.2	10.71	232.83
Ethanol	46	2.04	0.044	10.0	10.50	236.76
Propanol	60	2.02	0.034	10.2	10.71	318.12
Butanol	74	0.98	0.013	10.6	11.13	840.43
Second set of results						
Methanol	32	1.2	0.037	11.0	11.55	308.00
Ethanol	46	2.36	0.051	10.2	10.71	208.75
Propanol	60	0.78	0.013	10.2	10.71	823.85
Butanol	74	1.04	0.014	10.2	10.71	762.06

I will use the average of these results to plot my graphs:

Alcohol	Number of carbons	Molar Mass (g/mol)	Average energy released per mole (kJ)
Methanol	1	32	270.42
Ethanol	2	46	222.76
Propanol	3	60	570.99
Butanol	4	74	801.24

The theoretical data

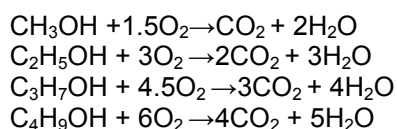

From these equations for the complete combustion of each of the alcohols, I can collate the following table:

Number of bonds		Methanol	Ethanol	Propanol	Butanol
To break	C-C	0	1	2	3
To break	C-H	3	5	7	9
To break	C-O	1	1	1	1
To break	O-H	1	1	1	1
To break	O=O	1.5	3	4.5	6
To reform	C=O	2	4	6	8
To reform	O-H	4	6	8	10

I also know the average bond energies, which is the energy that is needed to break the bonds or that is produced when they form. These energy are listed below:

Bond	Average bond energy (kj)
C-C	346
C-H	413
C-O	358
O-H	464
O=O	498
C=O	803

With the information above I can work out how much energy will be needed to break the bonds and how much will reform thus the total energy produced per mole:

Alcohol	Total energy input (kj)	Total energy released (kj)	Overall energy output (kj)
Methanol	2808	3462	654
Ethanol	4727	5996	1269
Propanol	6646	8530	1884
Butanol	8565	11064	2499

From the table an extra 615kj of energy are released as we go down the group of alcohols.

This occurs as each alcohol going down the group has as extra:

2 C-H bonds = 826kj

1.5 O=O bonds = 747kj

1 C-C bond = 346 kj to break

A total of 1919 kj extra to be put in. However there is an extra:

2 C=O = 1606kj

2 O-H = 918kj being released.

This means that a total of 2534 kj of energy is being released each time

This is where the 615 kj of energy increase comes from (2535kj – 1916kj)

Green transport

Today most transport in the world uses fossil fuels to provide the energy needed. This is not sustainable because

- fossil fuels are a non-renewable (finite) energy resource
- burning fossil fuels puts 'greenhouse gases' into the atmosphere.

- 1 Process the data you have collected and plot a graph of the results of your investigation into the energy transferred from fuels.

The bar chart showing my results and the theoretical ones is attached.

- 2 Describe any patterns or trends in your results. Comment on any unexpected results.

The trend in my results does show that the larger the molecular size of the fuel the greater the amount of energy liberated per mole. This trend is shown by the results for methanol, propanol and butanol but the results for ethanol are clearly anomalous. There is a degree of internal consistency for the two separate experiments for ethanol (236.76 kJ/mole and 208.75 kJ/mole) and this consistency is greater than that for propanol (318.12 and 823.95) and it is possible that the ethanol was not pure enough. The availability of pure ethanol is restricted because it can be drunk or diluted to make drinks so it is mixed with methanol to prevent it being drunk. However 'ethanol' contains approximately 10% of methanol to make it undrinkable but this amount of addition would not significantly affect the energy released on combustion. This is one possible reason for the anomalous results for ethanol. Another reason could be that the ethanol had been accidentally diluted and was possibly only 75% pure. This could reduce the amount of energy released because the water would be converted into steam in the flame but would not release any energy.

- 3 Compare the data on energy provided by alternative fuels from your research (Part 1) with the results of your own experiment (Part 2).

Comment on any similarities and differences. Suggest possible reasons for any differences.

The experimental results I obtained are supported by the theoretical figures I worked out using the bond energy calculations. But they are significantly smaller. Not all of the heat energy produced by the combustion actually reaches the tin and heats the water. Some of the energy simply heats the atmosphere or draughts and eddies cause problems. A wind shield around the burner would have helped, but while the patterns are similar my experiment is not very efficient because the apparatus I used is simple. Hi-tech apparatus used to prevent heat losses would have made it more efficient and the results more reliable and valid. The pattern in both sets is the same though.

- 4  Evaluate your results, the method you used and how well you managed the risks.

I think that to find a general trend my method was adequate however it did have faults for example a lot of energy would be lost to the surrounding for example the air.

This could be prevented by using the piece of apparatus called a calorimeter, which is designed to trap as much heat as possible and to use it warm the water.

This would also decrease the other problems such as evaporation as the calorimeter is a sealed piece of apparatus not allowing any vapour to escape. The evaporation would be a problem on two accounts, one is that energy from the alcohols would have ended up giving the water molecules the energy they need to escape, but also as the water evaporated there would have been less and less water to heat thus making the results less accurate. Another problem was the accurate measuring of water to exactly 250cm^3 as using a measuring cylinder is perhaps not accurate enough. A pipette or burette would have been better as these are very accurate pieces of equipment for measuring liquids. One other problem with the experiment is the presumption that complete combustion happened. Although there should have been plentiful oxygen in the air, any sudden shortage would have left carbon being formed or carbon monoxide this would mean that not all the predicted energy would have come out of the reactions.

A solution to this problem would be to add small controlled amount of oxygen to the flame area to definitely provide plenty of oxygen to allow complete combustion to happen.

- 5 Do your results from Part 2 support the hypothesis you suggested? Explain your answer.

The results that I got are nowhere near the same as the predicted results even though they show the same trend; this is due to the fact that so much energy was lost to the environment through the air touching the flame and the problem of evaporation.

I believe that there if no reason why this trend could be disputed as it is constant in the results and can be proven by theoretical means. I therefore think that my results are good enough to convince other people of my findings.

I think that there is sufficient evidence to support my hypothesis:

'...that the more bonds which are broken/formed in a combustion reaction the more energy is released.'

6 Which fuel is most likely to be a successful alternative to petrol for powering a car?

Explain why, using information from your research (Part 1) and your investigation (Part 2).

The best alternative fuel for use in a car will need to be one with a large molecular formula. The evidence shows that large molecules give out more energy on complete combustion. The figures given at the top of part 2 for bio diesel and ethanol show this. The table I got from the internet also confirms this. Petrol gives 109000 to 125000 per gallon and bio diesel gives 117000 to 120000 per gallon in BthU. This is about 90% of that of petrol and higher than bio ethanol. However the answer in practice is not this simple because of the need to use the land for fuel production rather than for food for people, and this will affect the decisions made when the petrol does run out. Fuel cells or hydrogen generated from 'green' electricity is probably more realistic.

Green Transport

Bar charts are the only way of displaying the data. The independent variable (number of carbon atoms) is categoric not continuous. A line of best fit cannot be drawn, but the trends can be identified by inspection.

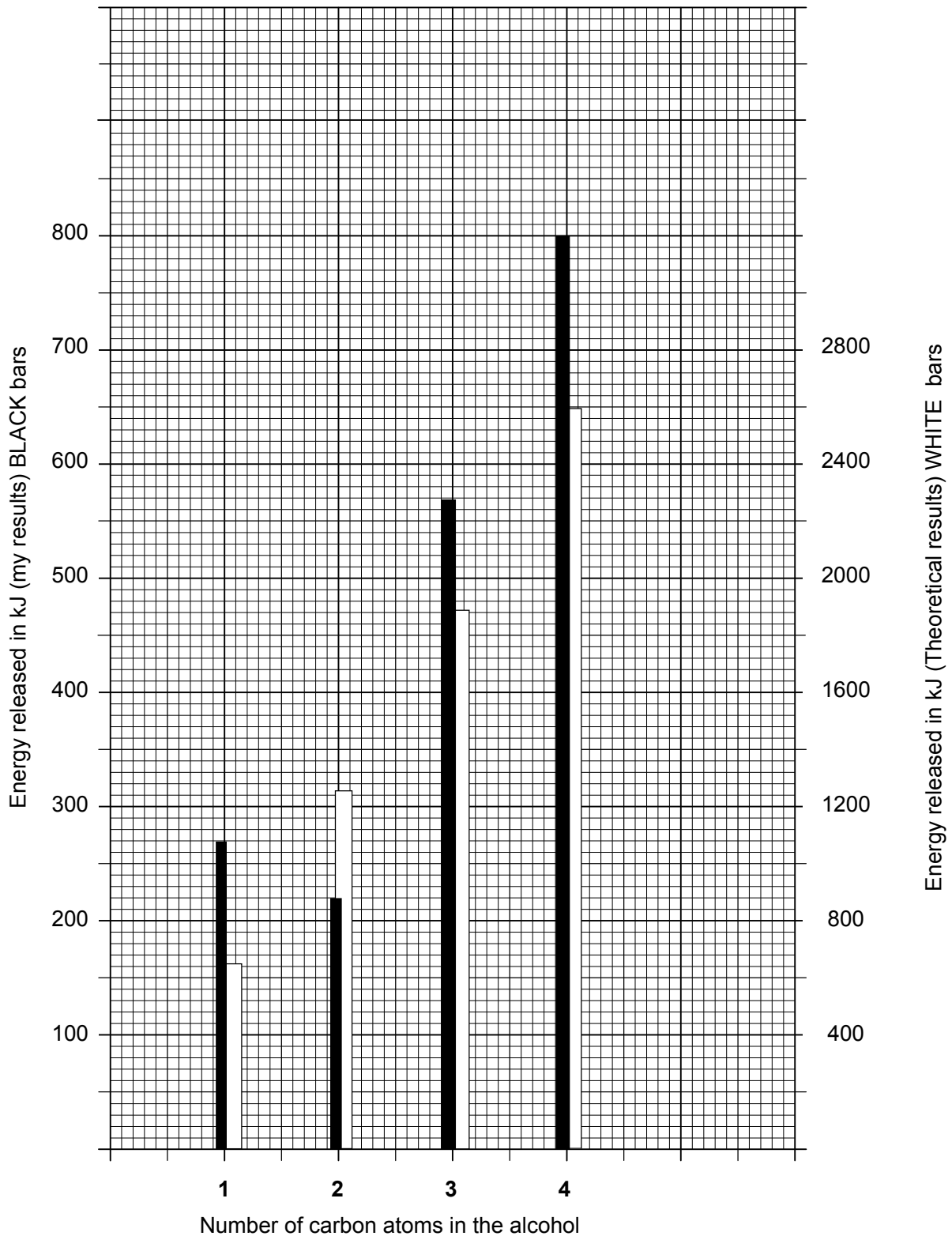

COMMENTARY FOR CANDIDATE E

Quality	Level L, M or H	Mark	Comments
Researching	H	6	In the five/six box certainly. What else could the candidate have written?
Planning	H	5	Not enough of the fine detail to support 6 ?
Collecting data	H	6	Clearly sufficient for a match to six marks.
Managing risk	-	0	No mention made at any point about risk. Must be zero.
Processing data	H	5	Graphing is high quality but account lacks much quantitative treatment of the uncertainty.
Analysing & interpreting	H	5	Certainly a match in the five/six box, but treatment not enough for a match to six.
Evaluating	M	4	Better match to the three/four box than to the five/six one. A good 'solid' – 'no argument' – four marks ?
Conclusion	M	4	Answer is brief and seems to be a better match to four marks rather than to a 'doubtful' match to five, but answer may be space-limited.
	Total	35	

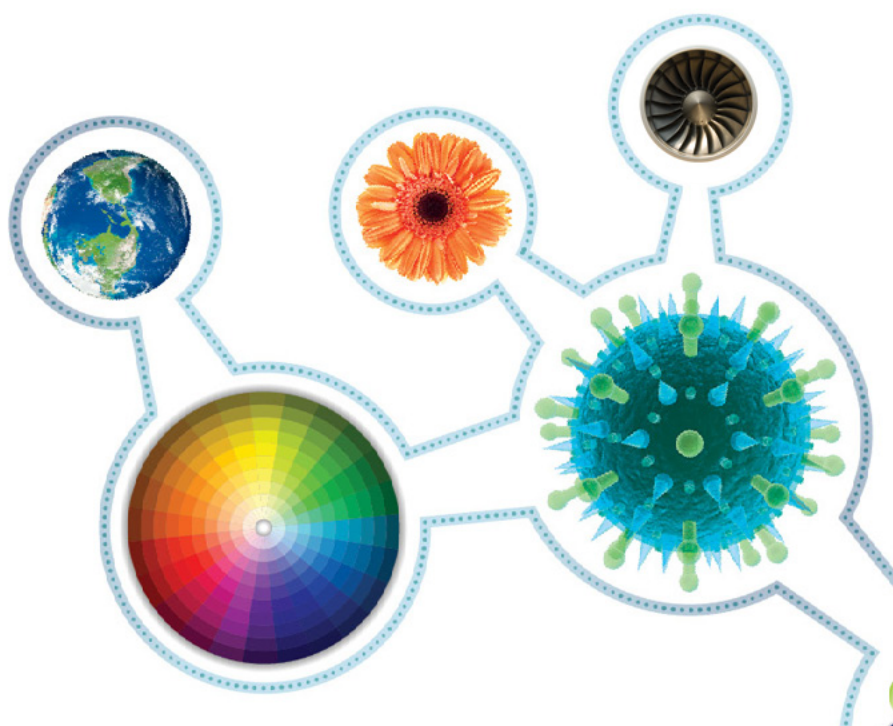

CHEMISTRY CANDIDATE F

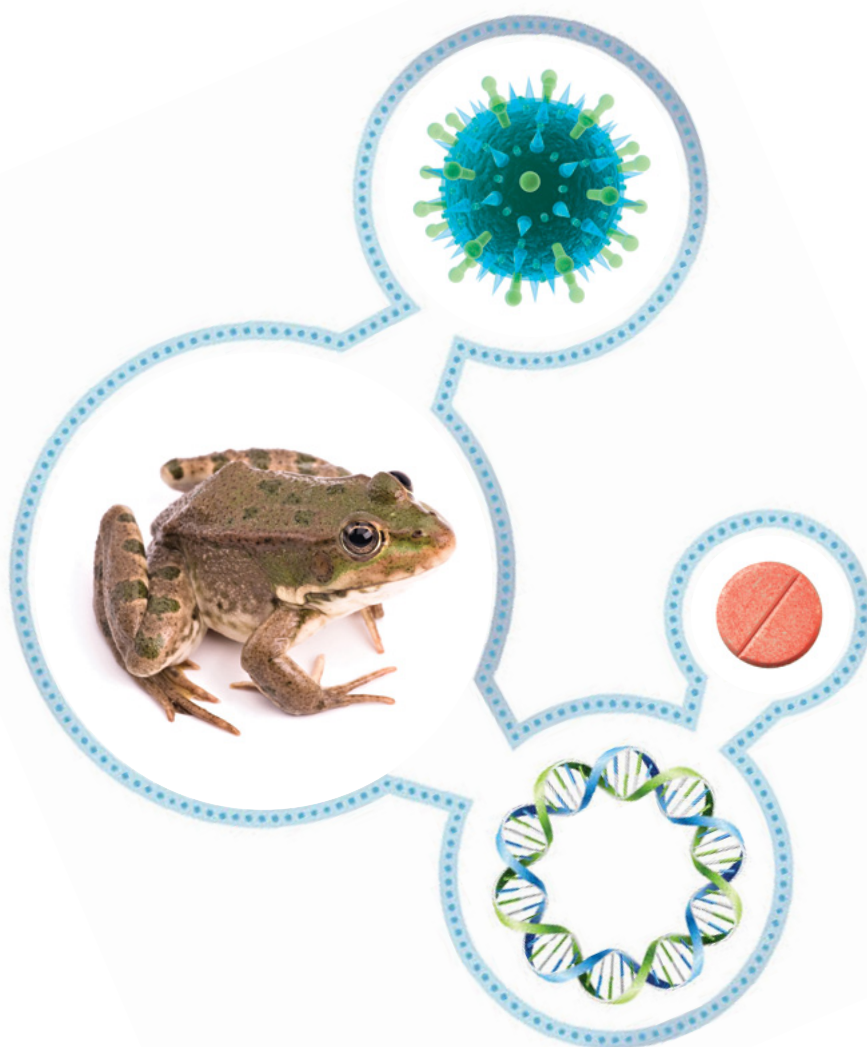

Green Transport

Part 1: Research

Oil is running out for the next generation so we need to find alternative fuels.

This is what I found out from my research.

Bio-diesel: made from plants or from old fish and chip oil

Bio-ethanol: made from plants and fermented

Bio-gas: made from rotting human sewage or from twitch grass in a waste decomposer.

CNG which is compressed natural gas and is a mix of propane and butane.

Hydrogen : made from water using electricity.

Electric car doesn't use petrol or diesel

Fuel cells use hydrogen and air to make electricity.

These are all alternative fuels which we will have to use in the future.

Biodiesel gives out more energy than petrol or ordinary diesel and is more efficient than petrol but gives off more NOx.

The more carbon there is in a substance the more energy is given out.

Alternative fuels don't contain carbon so do not produce carbon dioxide

Where I got my information.

The computer's in the school library.

[http://www.direct.gov.uk/en/environment and green energy](http://www.direct.gov.uk/en/environment%20and%20green%20energy)

<http://www.fueleconomy.gov/feg/current.shtml>

and from a couple of science books.

Green Transport

My planning

Alcohol is $C_2H_5OH = 9$ atoms

Bikoldiesel is $C_{19}H_{34}O_2 = 55$ atoms

They burn in cars engine to make carbon dioxide(CO_2) = 3 atoms

and water(H_2O) = 3 atoms

My idea (hypothesis)

is that the bigger the number of atoms the more energy there is which can come from them

My plan

There are four alcohols to use in small burners. They are

Methanol CH_3OH

Ethanol C_2H_5OH

Propanol C_3H_7OH

Butanol C_4H_9OH

I will use these in four separate experiments to see how they heat some cold water in a metal can.

I will let each one burn until the temperature rise is 15 degrees.

I will always use the same amount of water each time (100 cm³)

I will measure the weight of the burner before and after and not the difference in readings.

If I am right the big alcohol will need less to raise it by 15 degrees because it has got more carbon atoms in it and changing them into CO_2 gives out the energy and there's more of them.

My apparatus

A metal can

A thermometer

A balance

A measuring cylinder

A tripod to stand the can on.

My results

Name of alcohol	Temp at start (degrees C)	Temp at end (degrees C)	Temp Rise (degrees C)	Weight at start in gms	Weight at end in gms	Weight used in gms
Methanol	18	33	15	180.74	179.30	1.44
Ethanol	16	31	15	172.96	171.83	1.13
Popanol	20	35	15	164.22	163.30	0.92
butanol	21	35	15	166.46	165.70	0.76

Green transport

Today most transport in the world uses fossil fuels to provide the energy needed. This is not sustainable because

- fossil fuels are a non-renewable (finite) energy resource
- burning fossil fuels puts 'greenhouse gases' into the atmosphere.

- 1 Process the data you have collected and plot a graph of the results of your investigation into the energy transferred from fuels.

This is at the end.

- 2 Describe any patterns or trends in your results. Comment on any unexpected results.

The results are what I thort theyd be.

The bigger the alcohol the more energy is given off and therefore the less is needed.

The four results do follow a pattern going down. There is a strong negative corellation

There are no unexpected results its nearly a strait line.

- 3 Compare the data on energy provided by alternative fuels from your research (Part 1) with the results of your own experiment (Part 2).

Comment on any similarities and differences. Suggest possible reasons for any differences.

The results I got are like the ones the others got in there experiments so we must all have got it more or less right.

- 4  Evaluate your results, the method you used and how well you managed the risks.

It all went OK but there were some drafts witch Cud have effected the readings and the heat to the water. The flames from the diffrent burners might have been different and this cud also have effected the readings.

I wore my safty glasses all the time and was carful not to burn meself with the flames. The water in the can didn't get to hot so it was not a danger. I had to be carful of the glass thermomenter in case it broke.

- 5 Do your results from Part 2 support the hypothesis you suggested? Explain your answer.

I said that the bigger the alcohol the less is needed to give the same amount of heat and this was true.

My hypothesis was proved to be right

Its all to do with the braking of the bonds in the atoms of the alcohols, the more there are the more energy is formed when they join up again.

6 Which fuel is most likely to be a successful alternative to petrol for powering a car?

Explain why, using information from your research (Part 1) and your investigation (Part 2).

Its got to be a big molecule with more atoms of carbon so that less of it is needed.

Bio-diesel contains more than bioethanol and can be put into ordinary cars without chaging the engine at all.

I think this is the best.

Weight of alcohol needed to heat 100 cm³ of water by 15 degrees C

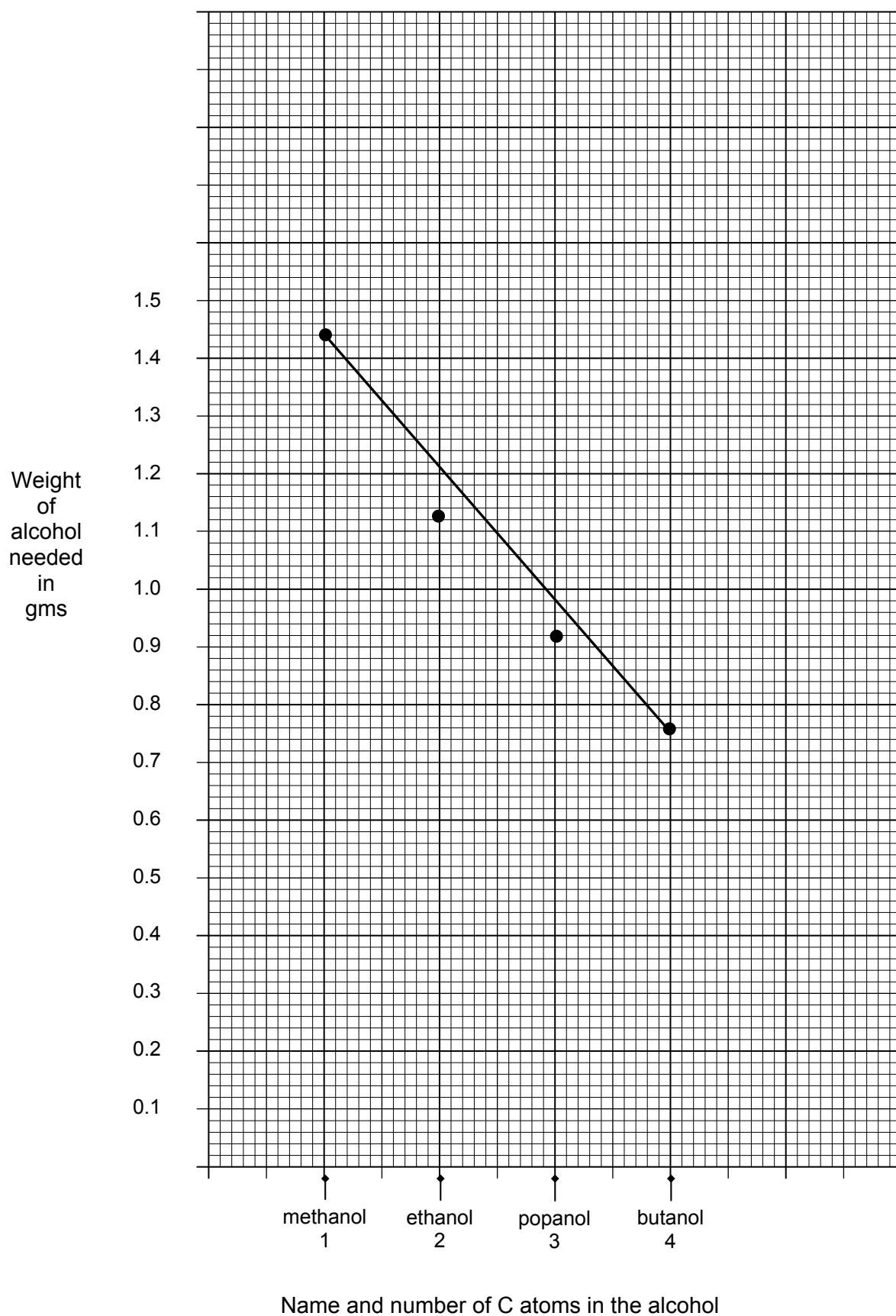

COMMENTARY FOR CANDIDATE F

Quality	Level L, M or H	Mark	Comments
Researching	M	3	Appears to be in the three/four box, but only just.
Planning	L	2	No replicates. Therefore confined to the one/two box.
Collecting data	M	4	Reasonable match to 4 marks.
Managing risk	L	2	Not enough detail to match the three/four box.
Processing data	M	4	In the three/four box.
Analysing & interpreting	L	2	Only in the one/two box.
Evaluating	L	2	Simplistic comments only.
Conclusion	L	2	Again, simplistic comments only.
	Total	21	

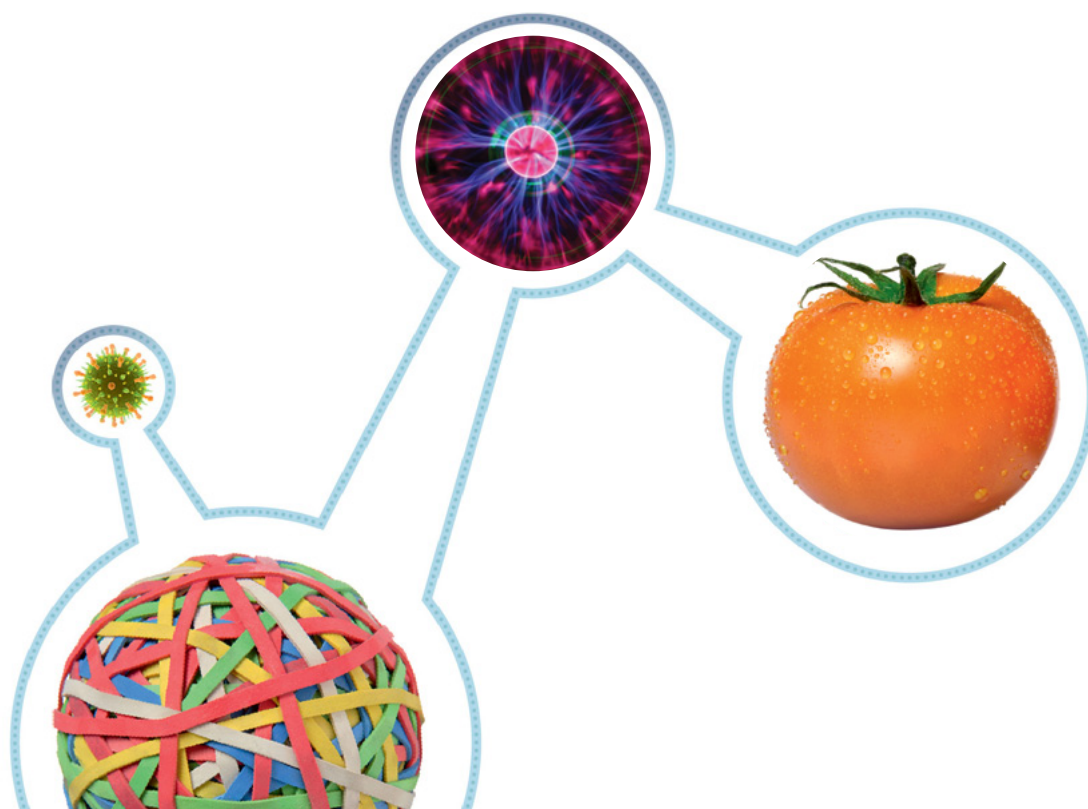

GENERAL QUALIFICATIONS

Telephone 01223 553998

Facsimile 01223 552627

science@ocr.org.uk

1 Hills Road, Cambridge CB1 2EU

For staff training purposes and as part of our quality assurance programme your call may be recorded or monitored.

© OCR 2011 Oxford Cambridge and RSA Examinations is a Company Limited by Guarantee. Registered in England.

Registered office 1 Hills Road, Cambridge CB1 2EU.

Registered company number 3484455. OCR is an exempt charity.

www.gcse-science.com