

Thursday 2 February 2012 – Morning

GCSE GATEWAY SCIENCE PHYSICS B

B652/02 Unit 2 Modules P4 P5 P6 (Higher Tier)

Candidates answer on the Question Paper.
A calculator may be used for this paper.

OCR supplied materials:
None

Other materials required:

- Pencil
- Ruler (cm/mm)

Duration: 1 hour



Candidate forename		Candidate surname	
--------------------	--	-------------------	--

Centre number						Candidate number				
---------------	--	--	--	--	--	------------------	--	--	--	--

MODIFIED LANGUAGE

INSTRUCTIONS TO CANDIDATES

- Write your name, centre number and candidate number in the boxes above. Please write clearly and in capital letters.
- Use black ink. HB pencil may be used for graphs and diagrams only.
- Answer **all** the questions.
- Read each question carefully. Make sure you know what you have to do before starting your answer.
- Write your answer to each question in the space provided. Additional paper may be used if necessary but you must clearly show your candidate number, centre number and question number(s).
- Do **not** write in the bar codes.

INFORMATION FOR CANDIDATES

- The number of marks is given in brackets [] at the end of each question or part question.
- A list of physics equations is printed on page two.
- The total number of marks for this paper is **60**.
- This document consists of **24** pages. Any blank pages are indicated.

EQUATIONS

$$\text{resistance} = \frac{\text{voltage}}{\text{current}}$$

$$v = u + at$$

$$s = \frac{(u + v)}{2} t$$

$$v^2 = u^2 + 2as$$

$$s = ut + \frac{1}{2} at^2$$

$$\text{momentum} = \text{mass} \times \text{velocity}$$

$$\text{force} = \frac{\text{change in momentum}}{\text{time}}$$

$$\text{refractive index} = \frac{\text{speed of light in vacuum}}{\text{speed of light in medium}}$$

$$\text{refractive index} = n = \frac{\sin i}{\sin r} \quad \begin{array}{l} i = \text{incident angle} \\ r = \text{refracted angle} \end{array}$$

$$\sin c = \frac{n_r}{n_i} \quad \begin{array}{l} c = \text{critical angle} \\ n_r = \text{refractive index of less dense material} \\ n_i = \text{refractive index of more dense material} \end{array}$$

$$\text{magnification} = \frac{\text{image size}}{\text{object size}}$$

$$V_{\text{out}} = V_{\text{in}} \times \frac{R_2}{(R_1 + R_2)}$$

$$\frac{V_p}{V_s} = \frac{N_p}{N_s}$$

$$V_p I_p = V_s I_s$$

Answer **all** the questions.

Section A – Module P4

1 Static electricity has many uses.

(a) One use of static electricity is in defibrillators.

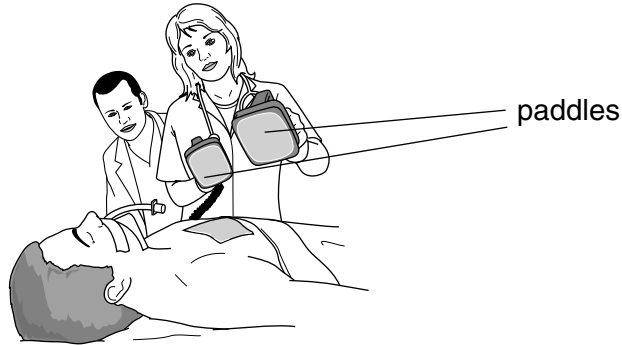

The paddles of the defibrillator are charged.

(i) Describe how the doctor restarts the patient's heart.

In your answer write about

- what the doctor does with the charged paddles
- how she makes sure charge reaches the heart.

.....
.....
..... [2]

(ii) What happens to the heart when the charge passes through it?

..... [1]

(b) Static electricity can be **dangerous**.

Describe **one situation** where static electricity is dangerous.

.....
..... [1]

(c) Static electricity can be useful for paint spraying.

Look at the diagrams.

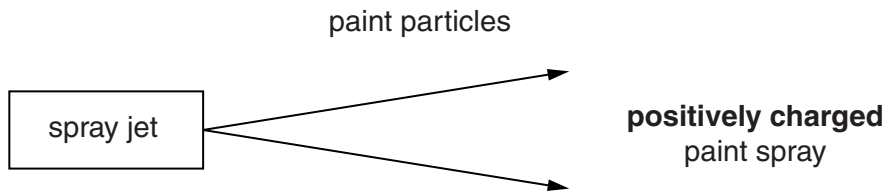
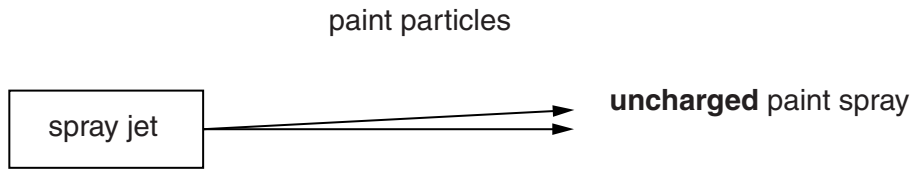

(i) Why does the positively charged paint spray spread out more?

.....

..... [1]

(ii) Look at the diagram.

The car is spray painted using electrostatics.

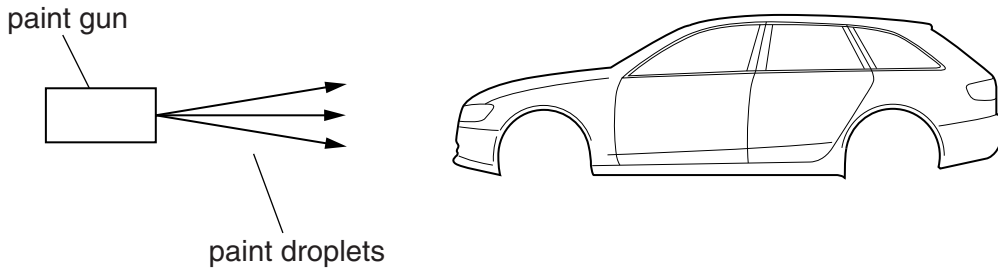

Electrostatics helps to completely cover the car in paint.

Explain how.

.....
.....
..... [2]

[Total: 7]

2 **Ultrasound** is used in hospitals.

Ultrasound has a very high frequency.

(a) What does **frequency** mean?

.....
..... [1]

(b) Write down one **use** for ultrasound in hospitals.

.....
..... [1]

[Total: 2]

3 Nuclear power stations use uranium in a nuclear reaction.

(a) In the nuclear reaction, uranium nuclei split.

What is the name of this process?

..... [1]

(b) There are many stages in the generation of electricity in a nuclear power station.

Look at this list.

turning a turbine

turning a generator

producing steam

producing heat

nuclear reaction

Complete the table by putting the five stages in the correct order.

Two stages have been done for you.

order	stage
1	nuclear reaction
2	
3	
4	
5	turning a generator

[1]

[Total: 2]

4 Amrit has three fuses she could put into a circuit.

Look at the diagram.

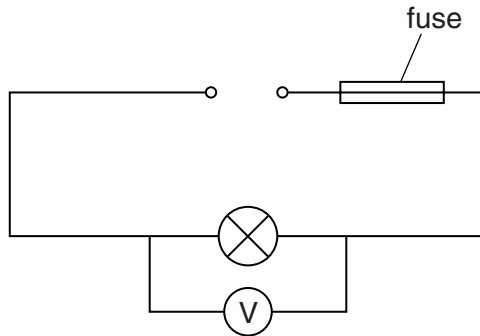

The voltage across the lamp is 230V.

The resistance of the lamp is 69Ω.

Amrit has a 3A, a 5A and a 13A fuse.

Calculate the **current** in the lamp and explain why the 5A fuse is the best choice.

The equations on page 2 may help you.

.....

answer A

The 5 A fuse is the best choice because

.....
 [3]

[Total: 3]

5 Alpha and beta radiations are emitted from unstable nuclei.

(a) An alpha (α) particle is a helium nucleus:

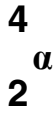

A uranium (U) nucleus decays to form thorium (Th) and an alpha particle.

Complete the nuclear equation for uranium decay.

Put an answer in each box.

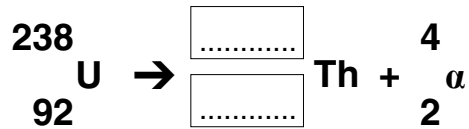

[1]

(b) A beta (β) particle is a fast moving electron from the nucleus:

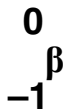

A radioactive carbon (C) nucleus decays to form nitrogen (N) and a beta particle.

Complete the nuclear equation for carbon decay.

Put an answer in each box.

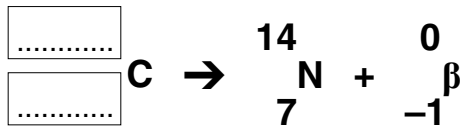

[1]

(c) Radioactive radium has a half life of 1600 years.

The count rate from a radium source is 1200 counts per minute.

How long will it take for the count rate to become 75 counts per minute?

Put a **ring** around the correct answer.

1 920 000 years

6400 years

3200 years

400 years

100 years

[1]

(d) Radioactive tracers can be used to find blockages in pipes underground.

Look at the diagram.

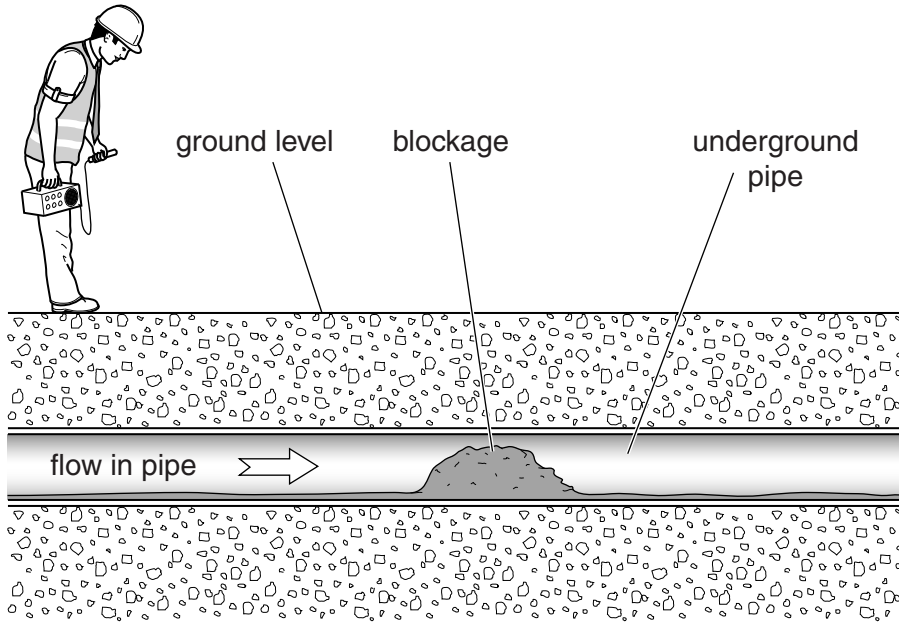

Explain in detail how a radioactive tracer can be used to find the blockage.

In your answer write about

- the type of tracer used
- where the tracer is placed
- where the radiation is detected
- how the blockage is found.

.....

.....

.....

.....

.....

..... [3]

[Total: 6]

Section B – Module P5

6 Simon and Dave are riding bikes.

(a) Look at the diagram of Dave riding his bike.

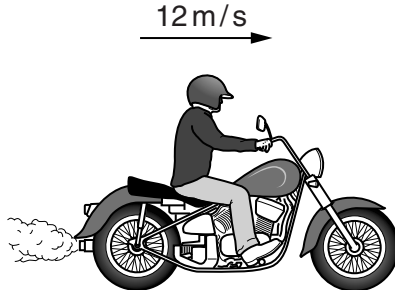

Dave has a mass of 80 kg and his bike has a mass of 220 kg.

His speed is 12 m/s.

Calculate the **momentum** of Dave and his bike.

The equations on page 2 may help you.

.....
.....

answer kg m/s [2]

(b) Dave's initial speed is 12 m/s.

He accelerates at 0.5 m/s^2 for 5 s.

Calculate Dave's **final** speed.

The equations on page 2 may help you.

.....
.....

answer m/s [2]

(c) Look at the diagram of Simon riding his bike.

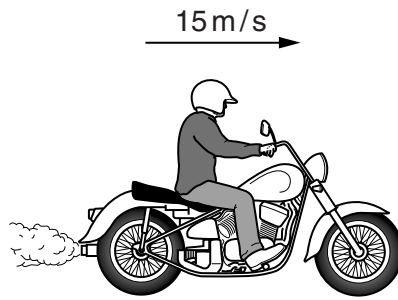

Simon **accelerates** from 15 m/s to 33m/s.

This takes 12 s.

Calculate the **distance** travelled during this acceleration.

The equations on page 2 may help you.

.....
.....

answer m

[2]

[Total: 6]

(b) Two transmitters labelled * emit circular waves of the same frequency.

Look at the diagram showing the crests of the waves.

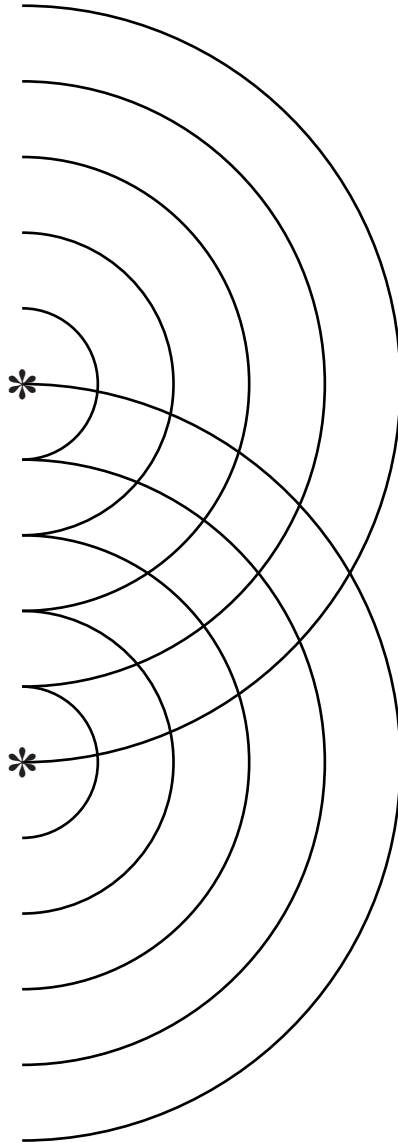

Clearly mark a point on the diagram to show where **constructive** interference occurs. Label this point **C**.

Clearly mark a point on the diagram to show where **destructive** interference occurs. Label this point **D**.

[2]

[Total: 6]

8 Look at the diagram of white light as it passes through a glass prism.

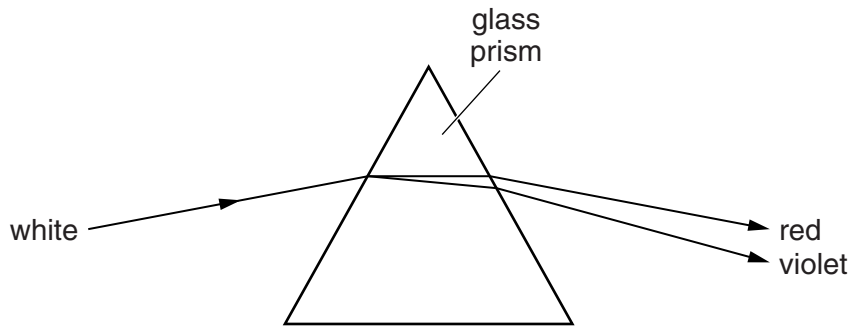

The white light disperses into a spectrum from red to violet.

Explain why red and violet light are deviated differently.

In your answer write about

- speed
- refractive index.

.....

.....

.....

..... [3]

[Total: 3]

9 A crash dummy is used for testing car safety.

The forces acting on the crash dummy are recorded.

The test car crashes into a barrier at 64 km/hr (40 miles per hour).

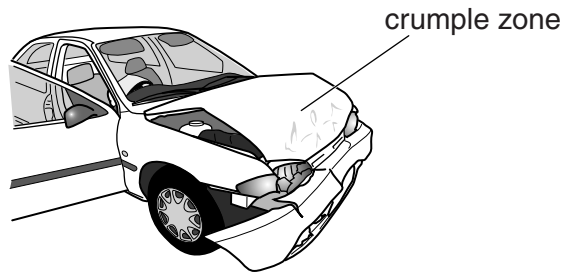

(a) The car and the barrier experience **forces**.

Describe the forces on the car and the barrier in terms of their size and direction.

size

.....

direction

..... [2]

(b) An identical car is fitted with an **improved** crumple zone.

This car also crashes into the barrier at 64 km/hr (40mph).

The improved crumple zone **reduces** the forces on the crash dummy.

Explain how.

The equations on page 2 may help you.

In your answer, use ideas about

- time
- momentum.

.....

.....

.....

.....

..... [3]

[Total: 5]

Turn over

Section C – Module P6

10 Asif sets up a circuit.

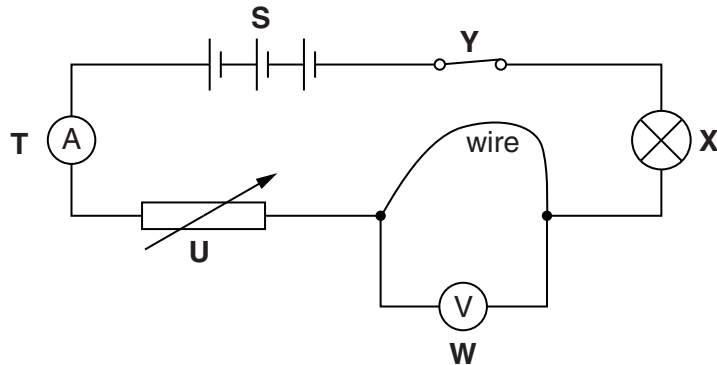

(a) There is a variable resistor (**U**) in the circuit.

If the value of the variable resistor is changed, it will change other things in the circuit.

Complete the sentence.

Decreasing the resistance of the variable resistor will **increase** the

in the circuit and the **brightness** of component [2]

(b) When the circuit is complete Asif writes down two measurements

- current through the wire = 0.4 A
- voltage across the wire = 8V.

Calculate the **resistance** of the wire.

The equations on page 2 may help you.

.....

.....

.....

.....

answer Ω

[2]

(c) Asif adjusts the variable resistor.

He records different values of current and voltage on the meters.

Look at his graph.

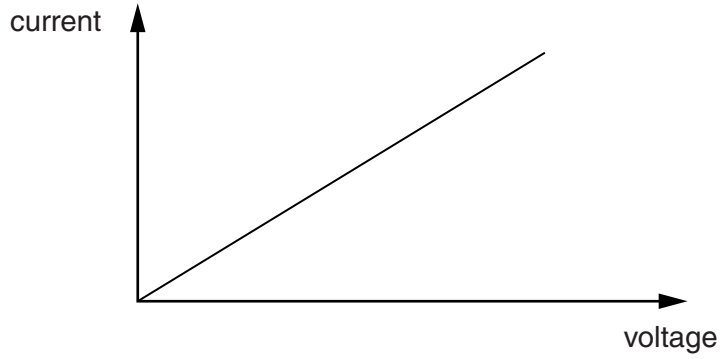

Describe how he can use the graph to calculate the **resistance** of the wire.

.....

.....

..... [2]

[Total: 6]

11 Georgina grows tomatoes in large greenhouses.

She wants to protect the tomatoes.

She designs an electronic system with three logic gates.

A buzzer sounds if it gets too **cold** during the **night**.

Look at the diagram of the electronic system.

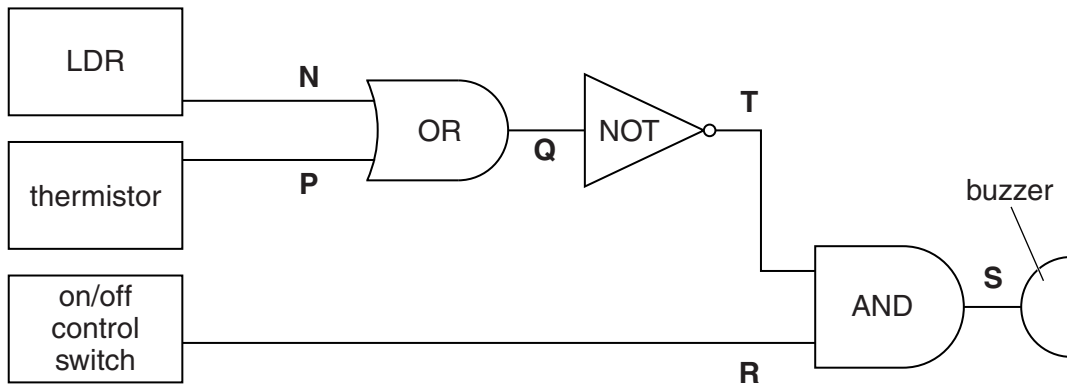

(a) The resistances of the LDR and the thermistor can change.

Complete the sentence about the **LDR**.

The resistance of the LDR **increases** when

..... [1]

(b) Georgina draws the truth table for her system.

It can describe how an electronic system works.

Part of her truth table is shown.

Complete the part of the truth table for Georgina's system.

Use it to explain how the system will tell Georgina when she needs to protect the tomato crop.

inputs to gates			Q	T	S
N	P	R			
0	0	0			
0	0	1			
0	1	0			
1	0	0			
1	1	1			

Explanation.

.....

.....

.....

.....

.....

..... [3]

- (c) The thermistor part of the system can be improved by using a variable resistor in a potential divider.

Look at the circuit that would do this.

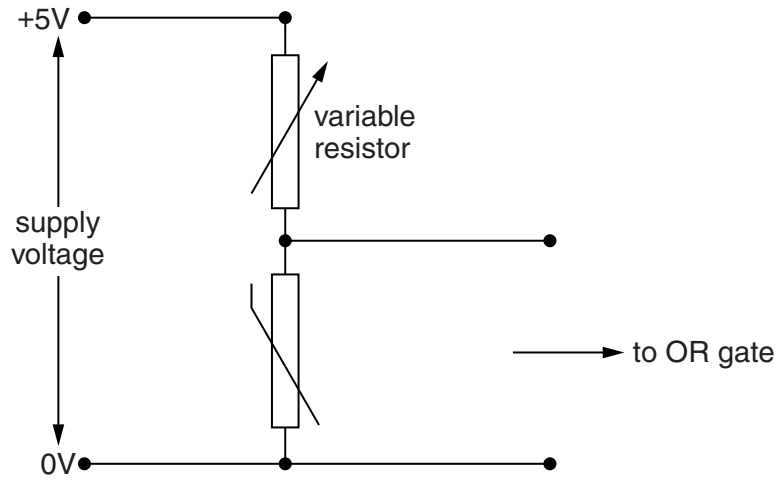

Complete the sentences to explain how this arrangement works.

As the temperature of the thermistor falls its resistance

This causes its share of the supply voltage to

This will the input to the OR gate.

If the variable resistor is adjusted, it will change the output from the potential divider and change the at which the OR gate switches on.

[3]

[Total: 7]

12 Jonas sets up a circuit to investigate a **capacitor**.

Look at the circuit.

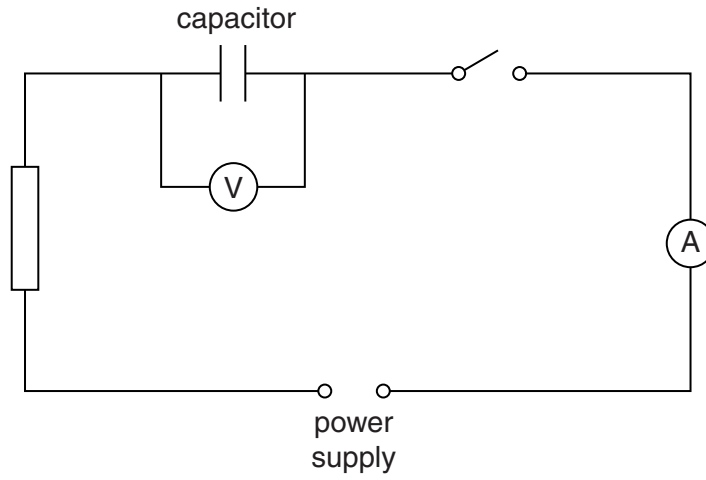

Describe what happens when the circuit is switched on.

In your answer include ideas about

- charge
- voltage.

.....

.....

.....

..... [3]

[Total: 3]

13 This question is about transformers and electric motors.

(a) Transformers are used in many everyday appliances.

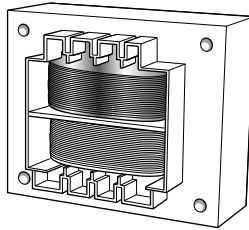

There are three types of transformer

- step up
- isolating
- step down.

Which type is used in a bathroom shaver socket?

answer

Explain how this type of transformer makes the circuit safer.

.....
..... [1]

(b) The diagram represents a transformer.

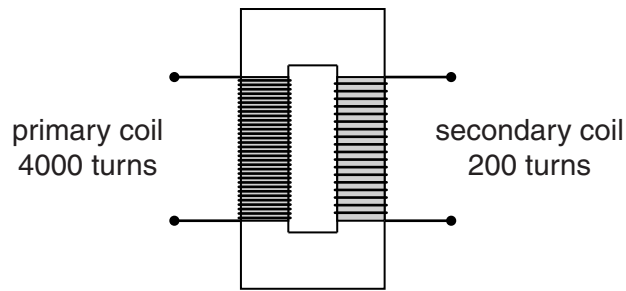

The following statements describe how a transformer works.

They are **not** in the correct order.

Put numbers in the **order** boxes to show the correct sequence.

One has been done for you.

statement	order
This produces an alternating magnetic field in the core.	<input type="text"/>
This produces an alternating current in the primary coil.	<input type="text"/>
This induces a voltage in the secondary coil.	<input type="text"/>
This produces an alternating magnetic field in the primary coil.	<input type="text"/>
This produces an alternating magnetic field in the secondary coil.	<input type="text"/>
An alternating voltage is supplied across the primary coil.	1

[2]

(c) Electric motors are used in many household appliances, such as washing machines.

They are different from the simple model motors made in class.

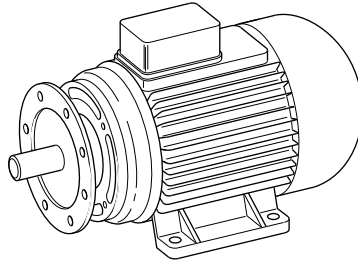

One of the main differences is that the magnets in the practical motor have **curved** poles.

This produces a **radial** magnetic field.

Explain how this improves the working of the motor.

.....
..... [1]

[Total: 4]

END OF QUESTION PAPER

Copyright Information

OCR is committed to seeking permission to reproduce all third-party content that it uses in its assessment materials. OCR has attempted to identify and contact all copyright holders whose work is used in this paper. To avoid the issue of disclosure of answer-related information to candidates, all copyright acknowledgements are reproduced in the OCR Copyright Acknowledgements Booklet. This is produced for each series of examinations and is freely available to download from our public website (www.ocr.org.uk) after the live examination series.

If OCR has unwittingly failed to correctly acknowledge or clear any third-party content in this assessment material, OCR will be happy to correct its mistake at the earliest possible opportunity.

For queries or further information please contact the Copyright Team, First Floor, 9 Hills Road, Cambridge CB2 1GE.

OCR is part of the Cambridge Assessment Group; Cambridge Assessment is the brand name of University of Cambridge Local Examinations Syndicate (UCLES), which is itself a department of the University of Cambridge.