

Candidate forename		Candidate surname	
-----------------------	--	----------------------	--

Centre number						Candidate number				
------------------	--	--	--	--	--	---------------------	--	--	--	--

**OXFORD CAMBRIDGE AND RSA EXAMINATIONS
GENERAL CERTIFICATE OF SECONDARY EDUCATION**

B652/02

GATEWAY SCIENCE

PHYSICS B

Unit 2: Modules P4 P5 P6 (Higher Tier)

FRIDAY 17 JUNE 2011: Afternoon

DURATION: 1 hour

SUITABLE FOR VISUALLY IMPAIRED CANDIDATES

**Candidates answer on the question paper.
A calculator may be used for this paper.**

OCR SUPPLIED MATERIALS:

None

OTHER MATERIALS REQUIRED:

Pencil

Ruler (cm/mm)

READ INSTRUCTIONS OVERLEAF

INSTRUCTIONS TO CANDIDATES

- **Write your name, centre number and candidate number in the boxes on the first page. Please write clearly and in capital letters.**
- **Use black ink. Pencil may be used for graphs and diagrams only.**
- **Read each question carefully. Make sure you know what you have to do before starting your answer.**
- **Write your answer to each question in the space provided. Additional paper may be used if necessary but you must clearly show your candidate number, centre number and question number(s).**
- **Answer ALL the questions.**

INFORMATION FOR CANDIDATES

- **The number of marks is given in brackets [] at the end of each question or part question.**
- **A list of physics equations is printed on pages four and five.**
- **The total number of marks for this paper is 60.**

BLANK PAGE

EQUATIONS

$$\text{resistance} = \frac{\text{voltage}}{\text{current}}$$

$$v = u + at$$

$$s = \frac{(u + v)}{2} t$$

$$v^2 = u^2 + 2as$$

$$s = ut + \frac{1}{2} at^2$$

$$\text{momentum} = \text{mass} \times \text{velocity}$$

$$\text{force} = \frac{\text{change in momentum}}{\text{time}}$$

$$\text{refractive index} = \frac{\text{speed of light in vacuum}}{\text{speed of light in medium}}$$

$$\text{refractive index} = n = \frac{\sin i}{\sin r} \quad \begin{array}{l} i = \text{incident angle} \\ r = \text{refracted angle} \end{array}$$

$$\sin c = \frac{n_r}{n_i} \quad \begin{array}{l} c = \text{critical angle} \\ n_r = \text{refractive index of less} \\ \quad \text{dense material} \\ n_i = \text{refractive index of more} \\ \quad \text{dense material} \end{array}$$

$$\text{magnification} = \frac{\text{image size}}{\text{object size}}$$

$$V_{\text{out}} = V_{\text{in}} \times \frac{R_2}{(R_1 + R_2)}$$

$$\frac{V_p}{V_s} = \frac{N_p}{N_s}$$

$$V_p I_p = V_s I_s$$

Answer ALL the questions.

SECTION A – MODULE P4

1 Nuclear power stations do not burn fuel.

(a) How is energy obtained from uranium during fission?

Finish the sentences.

A uranium atom is hit by a free

_____ .

This causes the _____ of

the atom to split and release energy. [2]

(b) Control rods are used in a nuclear reactor.

They make sure the chain reaction does not go out of control.

How do the control rods work?

_____ [1]

(c) Nuclear reactors produce energy.

In a power station, this energy is used to change water into STEAM.

How is the steam USED to produce electricity?

[2]

[Total: 5]

2 When an aircraft is being refuelled, the fuel travels from the fuel tanker to the aircraft in a pipe.

There is also a copper wire between the aircraft and the fuel tanker.

This wire carries electric charge.

(a) The fuel becomes charged as it flows along the pipe.

The copper wire becomes loose. It is now NOT attached to the aircraft.

The fuel pipe is disconnected. Suggest what might happen.

_____ [1]

(b) The charge on the fuel is positive.

Describe how the fuel becomes positively charged.

_____ [1]

(c) Static electricity can also be found in the home.

It can sometimes be a nuisance.

Write down one example where it is a NUISANCE.

_____ [1]

[Total: 3]

3 Sally builds this circuit.

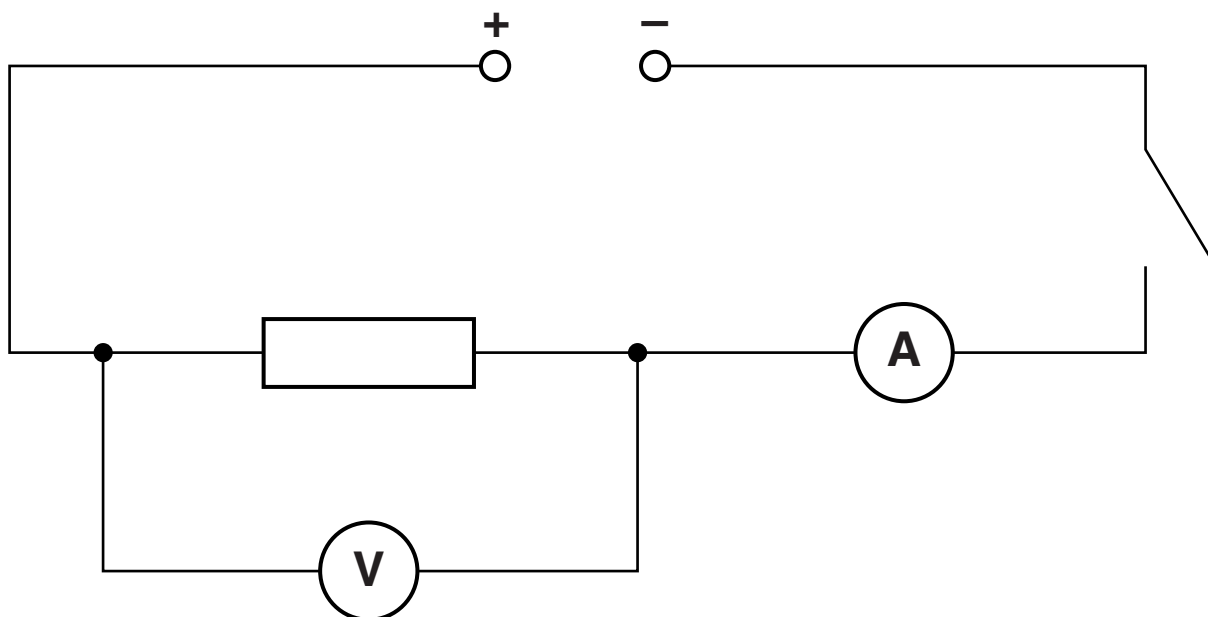

(a) She closes the switch. A current passes through the circuit.

Finish the sentence.

The current is caused by a flow of

_____ .

[1]

(b) The reading on the voltmeter is 6V.

The reading on the ammeter is 1.5A.

Calculate the resistance of the resistor.

The equations on pages 4 and 5 may help you.

answer _____ ohms

[2]

(c) Sally adds a 0.5 A fuse in series with the resistor.

(i) What happens to the fuse when the switch is closed?

_____ [1]

(ii) Why does this happen?

_____ [1]

Sally removes the fuse from the circuit.

(d) She changes the value of the resistor to 0.5 ohms and reduces the voltage to 2.5 volts.

Calculate the new value of the current.

The equations on pages 4 and 5 may help you.

answer _____ amps [2]

[Total: 7]

BLANK PAGE

4 Carbon-14 ($^{14}_6\text{C}$) is a radioisotope of carbon. It has a half-life of 5760 years.

It decays by emitting a beta particle.

(a) What is a BETA PARTICLE?

_____ [1]

(b) What isotope does carbon-14 decay into?

Put a **ring** around the correct answer.



[1]

(c) The Turin shroud is an ancient cloth.

Many people believe that it shows the image of the face of Jesus.



Radiocarbon dating was carried out on a sample of the cloth.

Radiocarbon dating provided an approximate age for the sample.

Explain how.

[2]

(d) Suggest one OTHER use for beta radiation.

[1]

[Total: 5]

SECTION B – MODULE P5

5 This question is about light.

Look at the diagram.

It shows a ray of white light striking a prism.

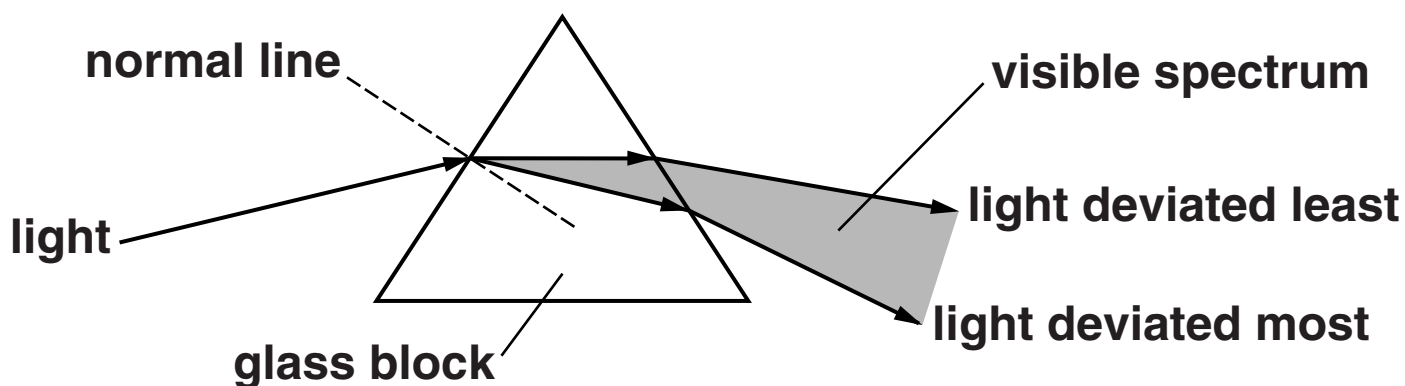

When the light hits the prism the light is deviated.

(a) The white light is dispersed to produce the different colours of the spectrum.

Explain why.

[1]

(b) Look at the diagram of light striking a different glass block.

It is incident at the critical angle, C .

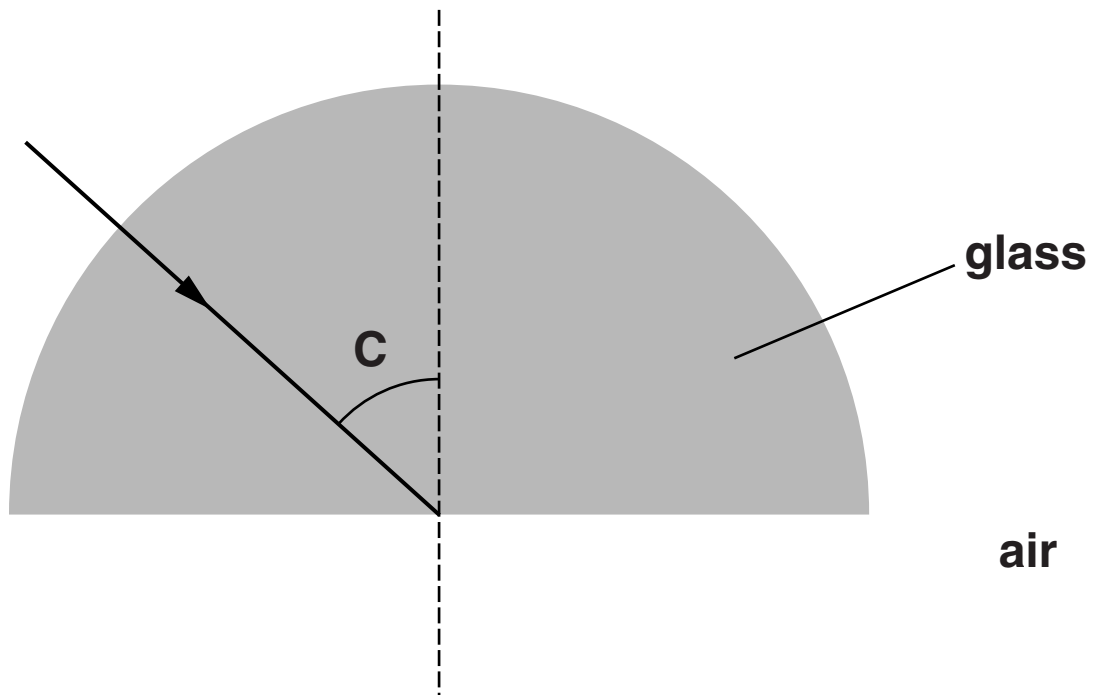

Continue the path of the ray on the diagram. [1]

[Total: 2]

6 This question is about communication.

(a) Long wave radio waves are used for communication.

They do NOT need to be reflected from the ionosphere or use satellites.

Look at the diagram.

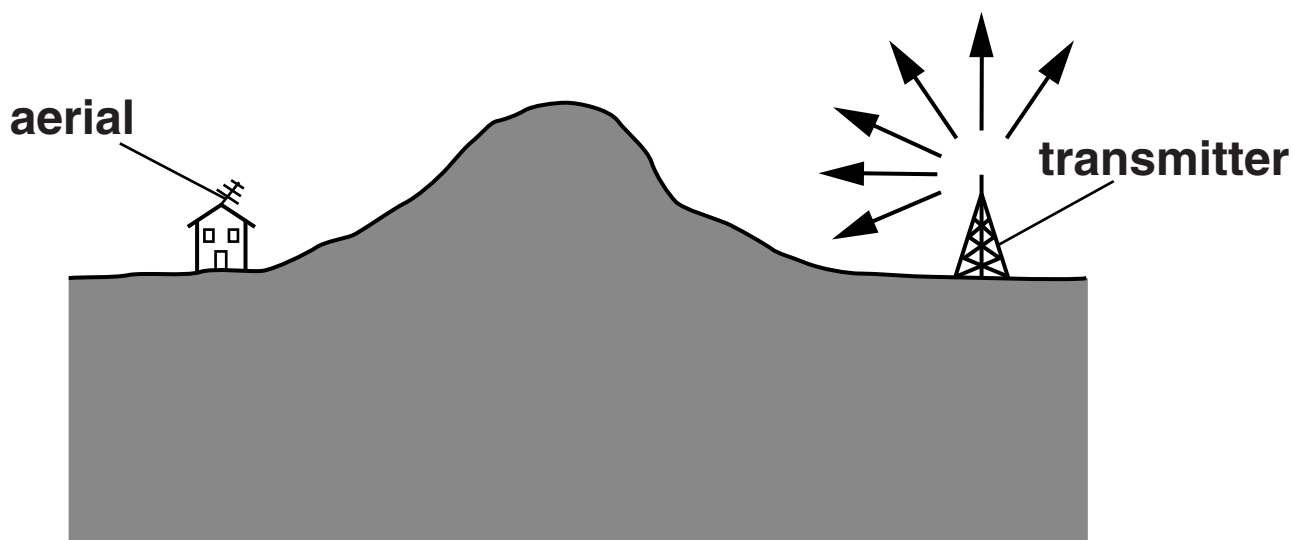

The waves from the transmitter reach the aerial.

Explain how.

[2]

(b) Waves can interfere with each other.

Describe what is meant by INTERFERENCE.

You may use a diagram in your answer.

[1]

- (c) Tracey investigates diffraction using water in a ripple tank.

Look at the diagram.

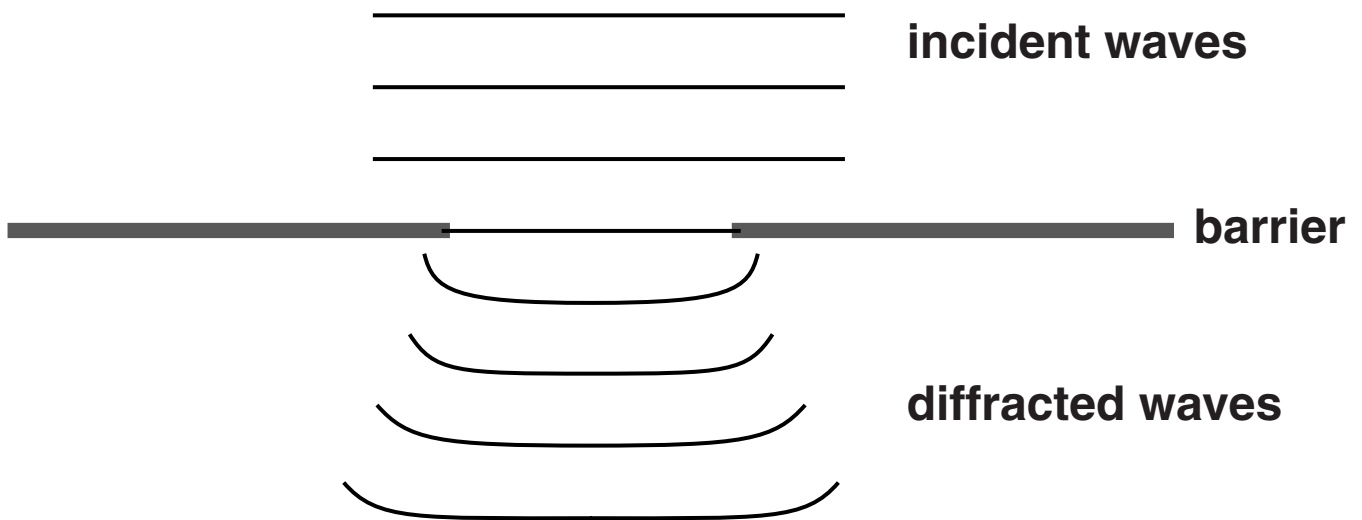

The amount of diffraction depends on the size of the gap and the wavelength of the wave.

- (i) Describe what happens if the gap is made **LARGER**.

_____ [1]

- (ii) Describe what happens if the wavelength is made **SHORTER**.

_____ [1]

- (iii) Tracey wants to produce maximum diffraction of the water wave.

What does she need to do?

_____ [1]

[Total: 6]

BLANK PAGE

7 (a) Ruth and Sam pull a sledge in the snow.

Look at the scale diagram.

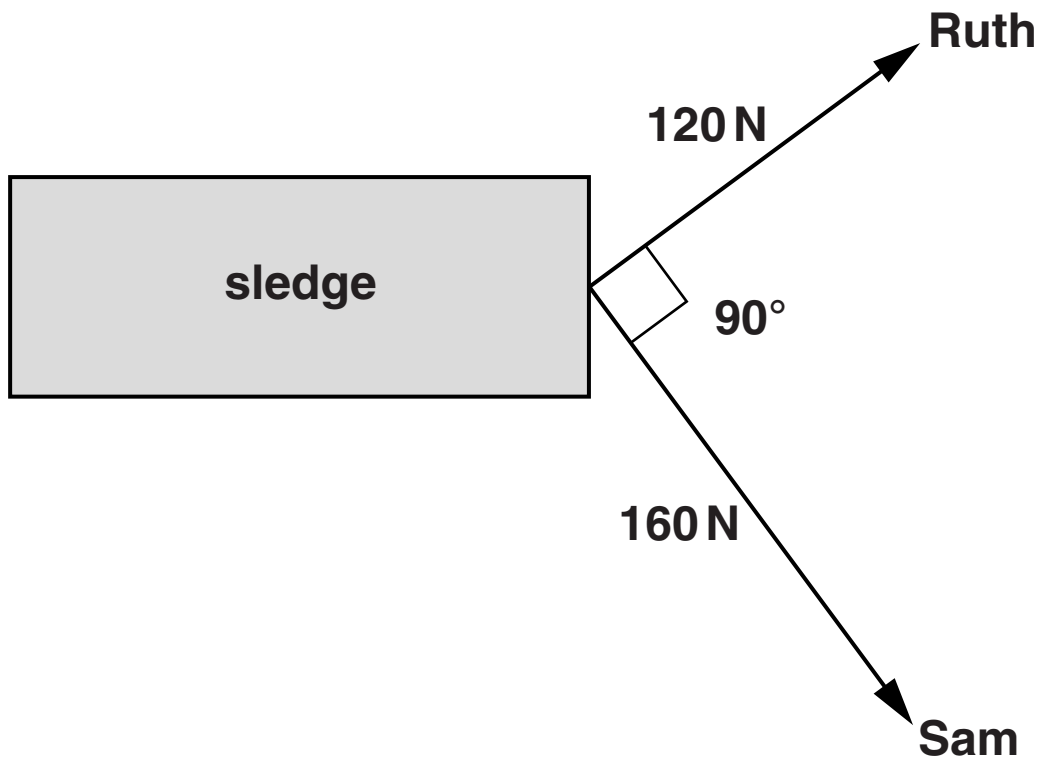

Ruth pulls with a force of 120 N and Sam pulls with a force of 160 N.

Calculate the resultant force on the sledge.

You may use the scale diagram to help you.

[2]

(b) Polly drops a stone from a hot air balloon.

It takes 8 seconds to reach the ground.

What is the speed of the stone when it hits the ground?

Ignore the effects of air resistance.

The acceleration (due to gravity) is 10 m/s^2 .

The equations on pages 4 and 5 may help you.

answer _____ m/s

[2]

(c) The table shows the gravitational force and the separation of two masses.

Look at the table.

SEPARATION (cm)	FORCE (units)
10	100
15	44
20	25
25	16
30	11
40	6

The results have been plotted on a graph.

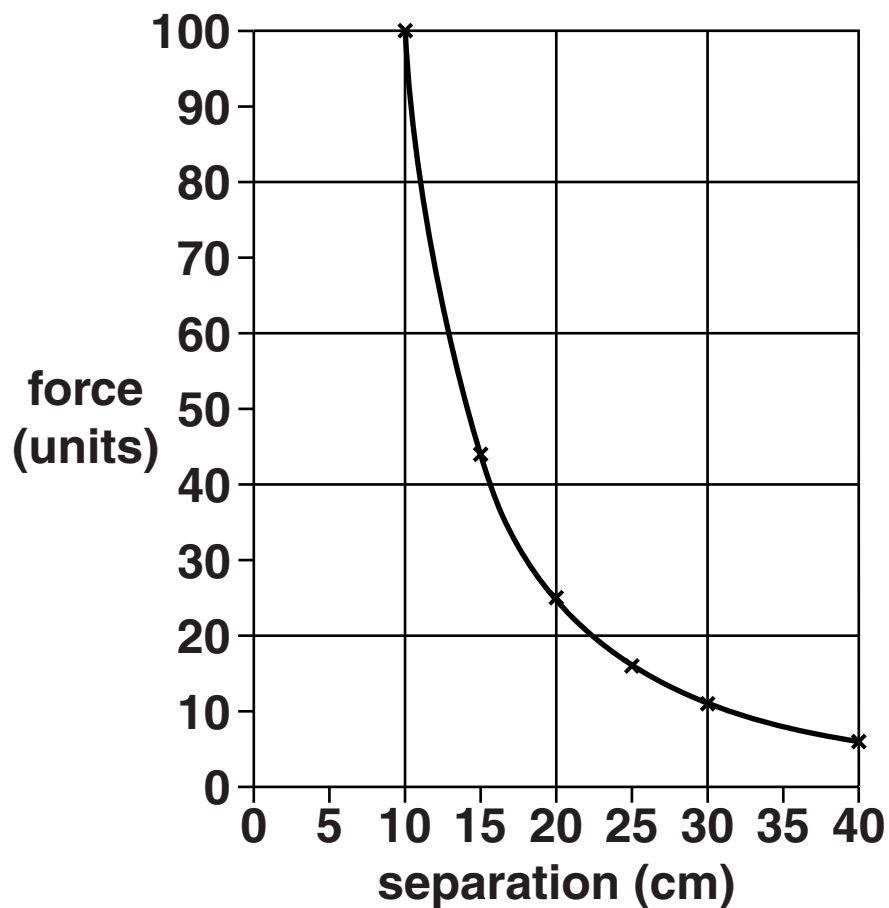

The gravitational force decreases with distance.

Describe IN DETAIL the shape of the graph.

[2]

(d) Satellites in HIGH GEOSTATIONARY ORBIT are kept in orbit by gravitational force.

They can be used for communication.

Write down one use of satellites in LOWER POLAR ORBIT.

[1]

[Total: 7]

8 People can get injured when a car crashes and comes to a sudden stop.

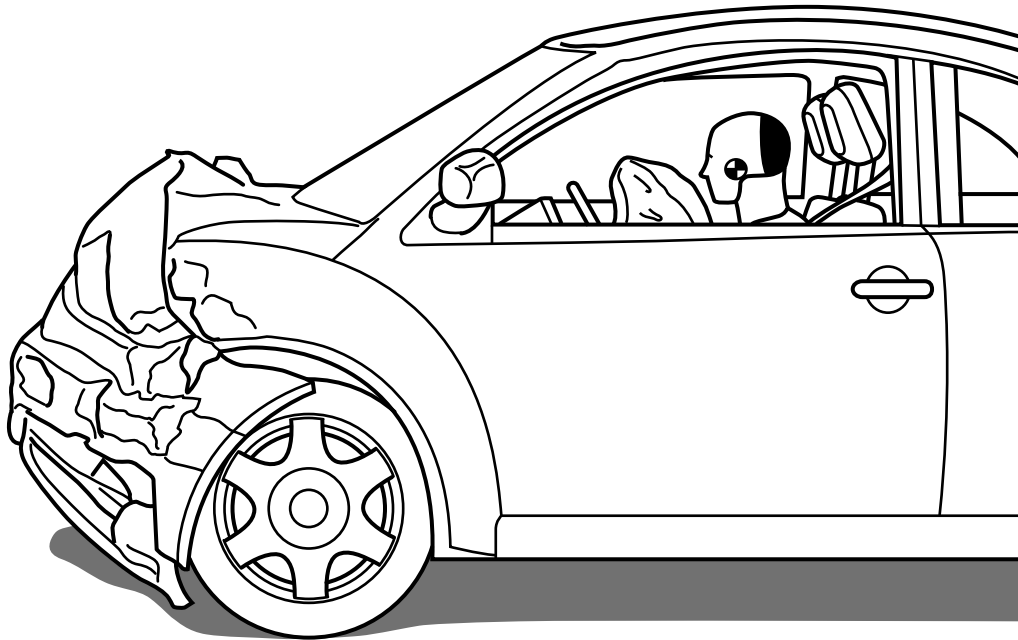

Explain how crumple zones can reduce these injuries.

Use ideas about MOMENTUM and TIME in your answer.

[2]

[Total: 2]

9 Tom has a lens camera.

He takes a picture of some mountains in the distance.

(a) What does the convex lens do to the image formed on the film?

_____ [1]

(b) He now wants to take a close up picture of a flower.

What must he do TO THE LENS to focus the image on the film?

_____ [1]

(c) Is the image produced in a simple camera real or virtual?

Explain your answer by completing the following sentence.

The image produced by a simple camera is

_____ because

_____ . [1]

[Total: 3]

SECTION C – MODULE P6

10 (a) Look at the diagram of an electric motor.

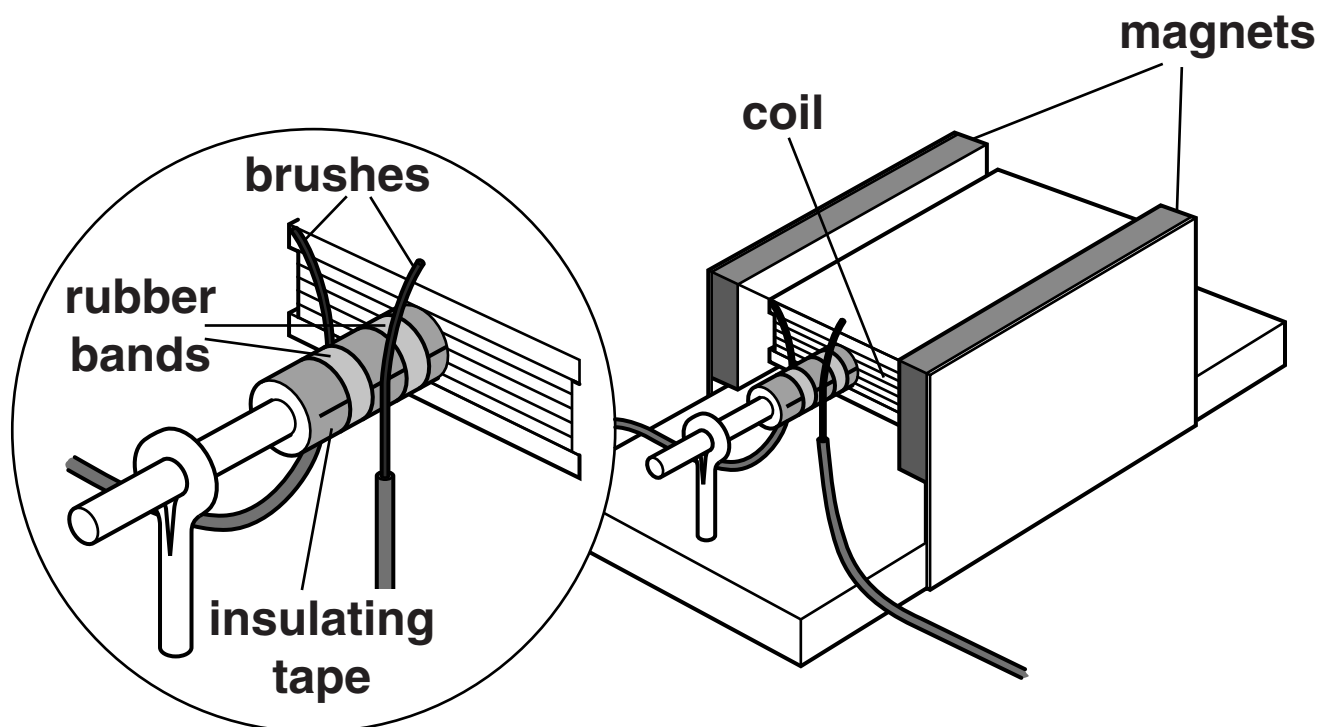

Current is passed through the coil.

The coil spins.

- (i) **What will happen to the motor if STRONGER MAGNETS are used?**

_____ [1]

- (ii) **What will happen to the motor if LESS CURRENT is used?**

_____ [1]

(b) Look at the diagram of a generator.

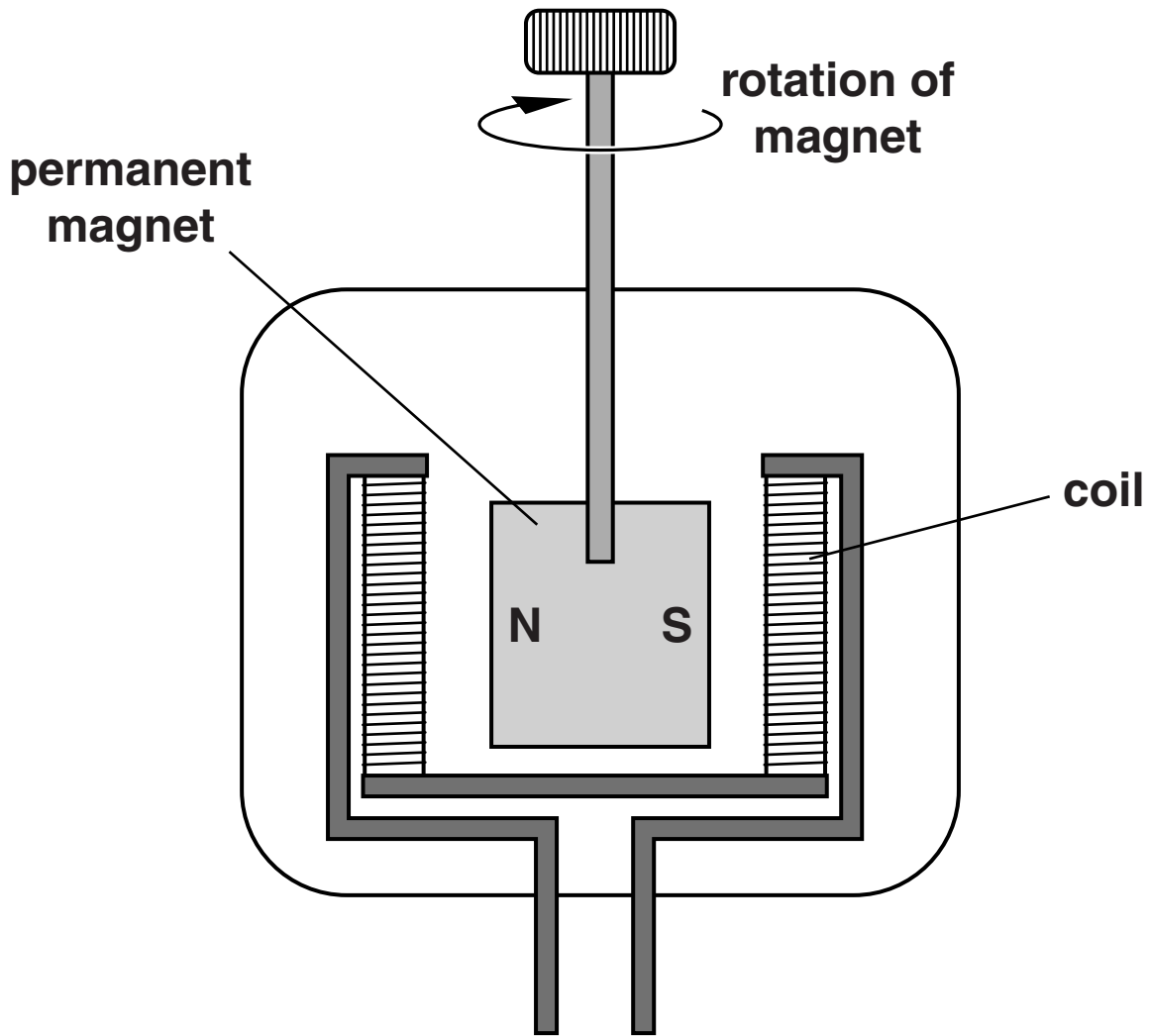

The magnet rotates inside the coil of wire.

(i) What TYPE of current is generated?

_____ [1]

(ii) The generator is turned more quickly.

Complete the sentence.

When the generator is turned more quickly the

VOLTAGE output _____ and

the FREQUENCY _____ . [1]

[Total: 4]

11 (a) An electric shaver is plugged into a socket in the bathroom.

This socket contains an ISOLATING transformer.

(i) Explain how an isolating transformer IMPROVES safety.

_____ [1]

(ii) An isolating transformer has 1500 turns on the primary coil.

Suggest how many turns there are on the secondary coil.

_____ [1]

(b) Look at the diagram of a transformer.

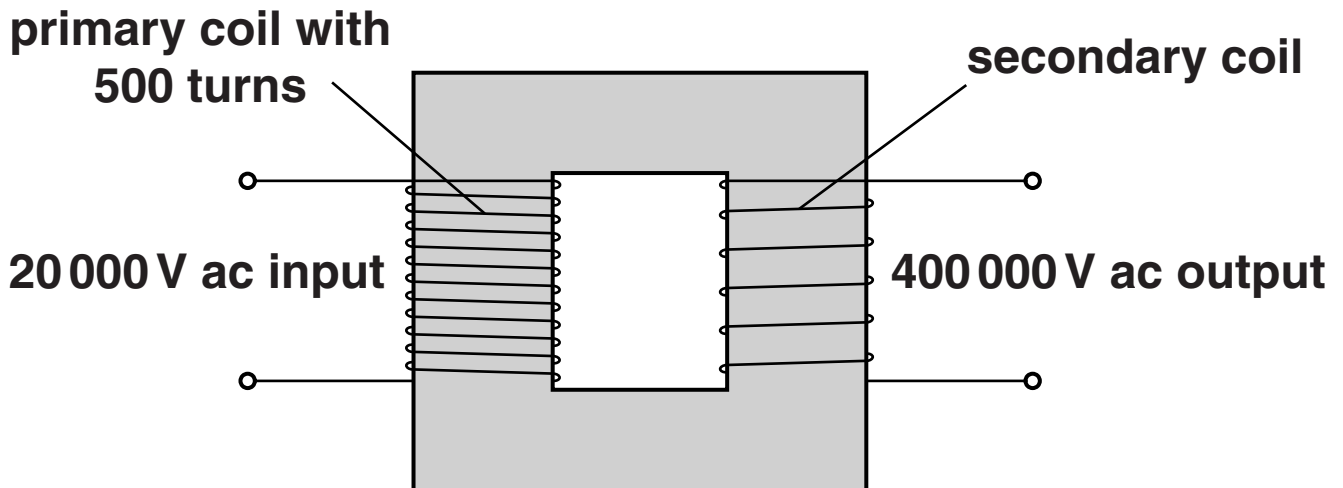

(i) The PRIMARY coil has 500 turns.

Calculate the number of turns on the SECONDARY coil.

The equations on pages 4 and 5 may help you.

answer _____ turns [2]

(ii) Step-down transformers REDUCE voltages.

They are CONSTRUCTED differently to step-up transformers.

Describe how they are different.

[1]

(c) The output from transformers is alternating current (AC).

Sometimes this needs to be changed to direct current (DC).

Diodes are used to do this.

A CAPACITOR is also used with the diodes.

Why is the CAPACITOR used?

_____ [1]

(d) Silicon diodes only let current flow in ONE direction.

A silicon diode works because of the movement of ELECTRONS and HOLES.

Explain how a silicon diode works.

In your answer

- write about electrons and holes**
- describe how charge moves.**

_____ [2]

[Total: 8]

12 Logic gates are used in electronic circuits.

(a) Complete the truth table for a NAND gate.

INPUT A	INPUT B	OUTPUT
0	0	
0	1	
1	0	
1	1	

[1]

(b) Logic gates are used with a RELAY to control mains circuits.

Explain why relays are used.

In your answer write about

- what the relay does**
- the currents involved**
- safety.**

[3]

[Total: 4]

13 Archie uses different electrical components in his experiments.

(a) Archie experiments with a bulb in a circuit.

He INCREASES the voltage across the bulb.

He measures the current.

He plots a graph of current against voltage.

He compares this graph with the graph for a resistor.

Look at the graphs.

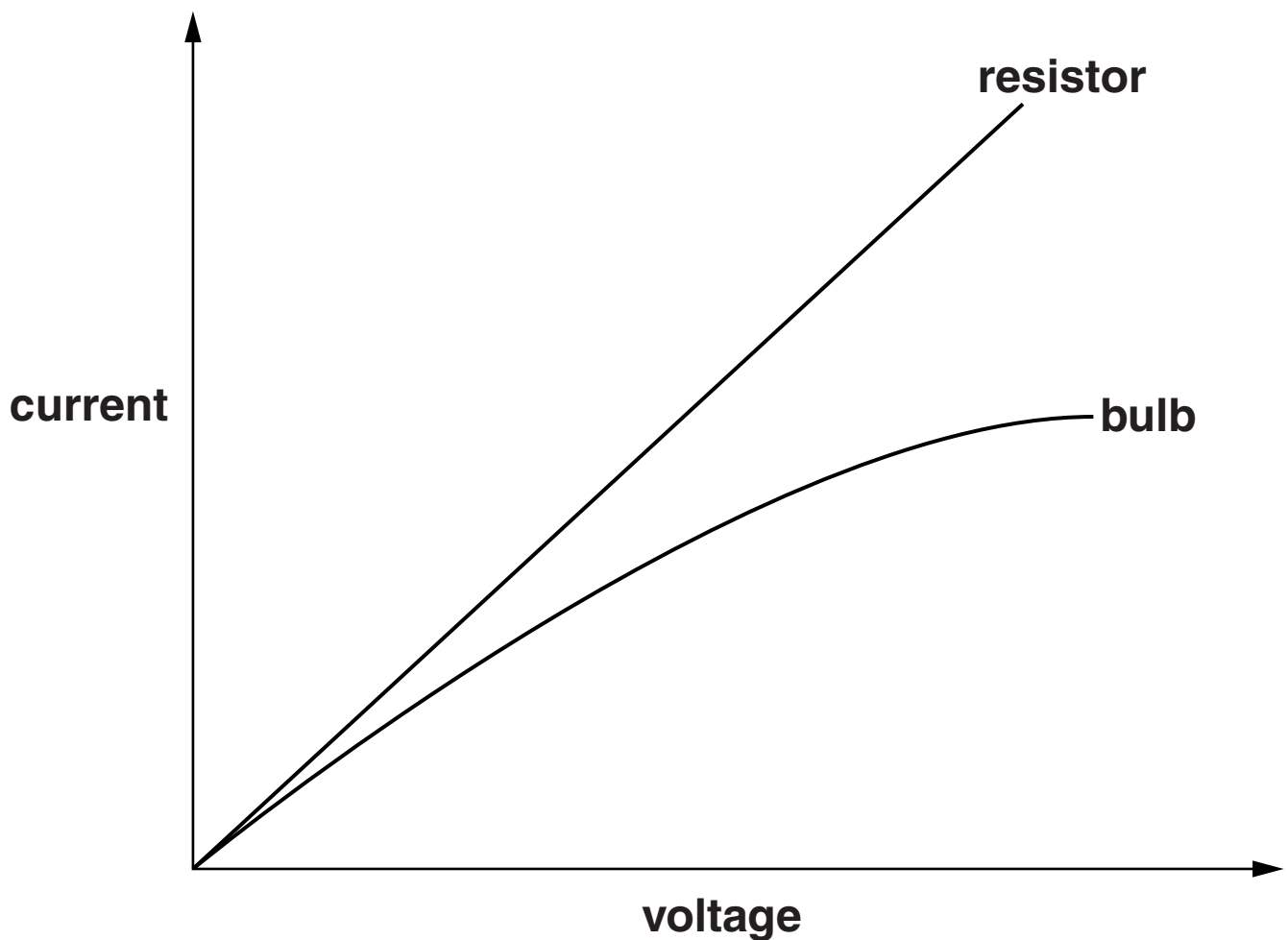

The graph for the bulb is NOT a straight line.

Suggest why.

_____ [1]

(b) Archie finds two more components.

They are a LDR and a THERMISTOR.

Complete the sentences about these components.

**The resistance of LDRs and thermistors can
increase or decrease.**

**LDRs have _____ resistance
when light levels get brighter.**

**Thermistors have more resistance when
temperature _____ . [1]**

[Total: 2]

14 A potential divider is made using two fixed resistors, R1 and R2.

Look at the diagram.

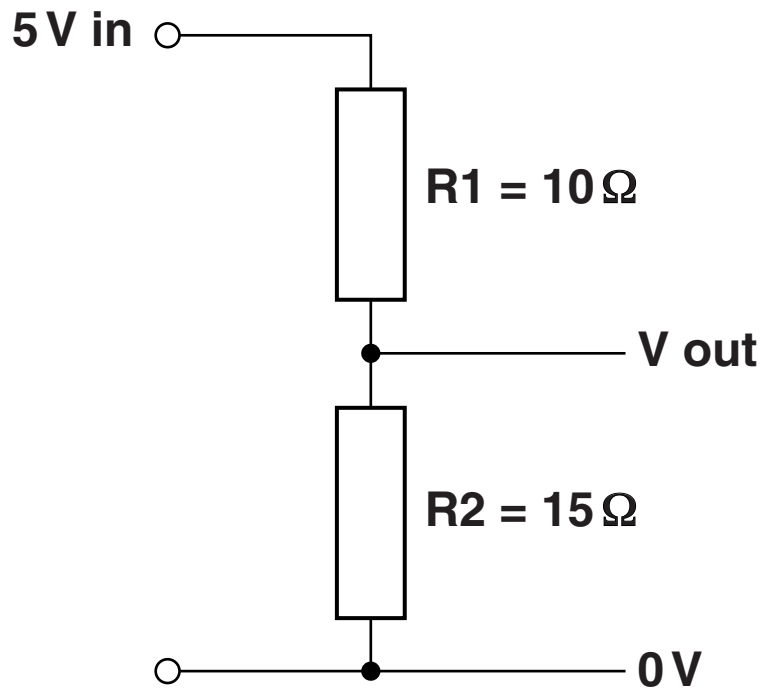

The INPUT voltage is 5V.

Calculate the OUTPUT voltage of the potential divider.

The equations on pages 4 and 5 may help you.

answer _____ V [2]

[Total: 2]

END OF QUESTION PAPER

BLANK PAGE

Copyright Information

OCR is committed to seeking permission to reproduce all third-party content that it uses in its assessment materials. OCR has attempted to identify and contact all copyright holders whose work is used in this paper. To avoid the issue of disclosure of answer-related information to candidates, all copyright acknowledgements are reproduced in the OCR Copyright Acknowledgements Booklet. This is produced for each series of examinations and is freely available to download from our public website (www.ocr.org.uk) after the live examination series.

If OCR has unwittingly failed to correctly acknowledge or clear any third-party content in this assessment material, OCR will be happy to correct its mistake at the earliest possible opportunity.

For queries or further information please contact the Copyright Team, First Floor, 9 Hills Road, Cambridge CB2 1GE.

OCR is part of the Cambridge Assessment Group; Cambridge Assessment is the brand name of University of Cambridge Local Examinations Syndicate (UCLES), which is itself a department of the University of Cambridge.