

Candidate Forename		Candidate Surname	
-----------------------	--	----------------------	--

Centre Number						Candidate Number				
------------------	--	--	--	--	--	---------------------	--	--	--	--

**OXFORD CAMBRIDGE AND RSA EXAMINATIONS  
GENERAL CERTIFICATE OF SECONDARY EDUCATION**

**B652/02**

**GATEWAY SCIENCE**

**PHYSICS B**

**UNIT 2 Modules P4 P5 P6  
(Higher Tier)**

**FRIDAY 19 JUNE 2009: Morning**

**DURATION: 1 hour**

**SUITABLE FOR VISUALLY IMPAIRED CANDIDATES**

**Candidates answer on the question paper**

**A calculator may be used for this paper**

**OCR SUPPLIED MATERIALS:**

**None**

**OTHER MATERIALS REQUIRED:**

**Pencil**

**Ruler (cm/mm)**

**READ INSTRUCTIONS OVERLEAF**

## **INSTRUCTIONS TO CANDIDATES**

- **Write your name clearly in capital letters, your Centre Number and Candidate Number in the boxes on the first page.**
- **Use black ink. Pencil may be used for graphs and diagrams only.**
- **Read each question carefully and make sure that you know what you have to do before starting your answer.**
- **Answer ALL the questions.**
- **Write your answer to each question in the space provided, however additional paper may be used if necessary.**

## **INFORMATION FOR CANDIDATES**

- **The number of marks is given in brackets [ ] at the end of each question or part question.**
- **The total number of marks for this paper is 60.**
- **A list of physics equations is printed on pages 4–5.**

**BLANK PAGE**

## EQUATIONS

$$\text{resistance} = \frac{\text{voltage}}{\text{current}}$$

$$v = u + at$$

$$s = \frac{(u + v)}{2} t$$

$$v^2 = u^2 + 2as$$

$$s = ut + \frac{1}{2} at^2$$

$$\text{momentum} = \text{mass} \times \text{velocity}$$

$$\text{force} = \frac{\text{change in momentum}}{\text{time}}$$

$$\text{refractive index} = \frac{\text{speed of light in vacuum}}{\text{speed of light in medium}}$$

$$\text{refractive index} = n = \frac{\sin i}{\sin r} \quad \begin{array}{l} i = \text{incident angle} \\ r = \text{refracted angle} \end{array}$$

$$\sin c = \frac{n_r}{n_i} \quad \begin{array}{l} c = \text{critical angle} \\ n_r = \text{refractive index of less} \\ \quad \text{dense material} \\ n_i = \text{refractive index of more} \\ \quad \text{dense material} \end{array}$$

$$\text{magnification} = \frac{\text{image size}}{\text{object size}}$$

$$V_{\text{out}} = V_{\text{in}} \times \frac{R_2}{(R_1 + R_2)}$$

$$\frac{V_p}{V_s} = \frac{N_p}{N_s}$$

$$V_p I_p = V_s I_s$$

Answer ALL the questions.

SECTION A – MODULE P4

1 Darren combs his hair.

(a) (i) The comb is NEGATIVELY charged.

What causes the comb to be negatively charged?

\_\_\_\_\_ [1]

(ii) Darren's hair is POSITIVELY charged.

Why does this make his hair stand on end?

\_\_\_\_\_ [1]

(b) He then puts the NEGATIVELY charged comb near to some small pieces of paper.

The top parts of the pieces of paper are POSITIVELY charged.

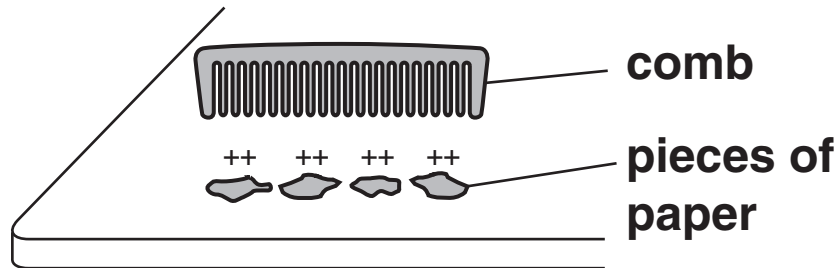

The pieces of paper are attracted to the comb.

Explain why.

---

---

[1]

[Total: 3]

2 This question is about how static electricity can be useful.

(a) One use is removing dust (smoke) particles from chimneys.

This is done using an ELECTROSTATIC PRECIPITATOR.

The diagram shows an electrostatic precipitator.

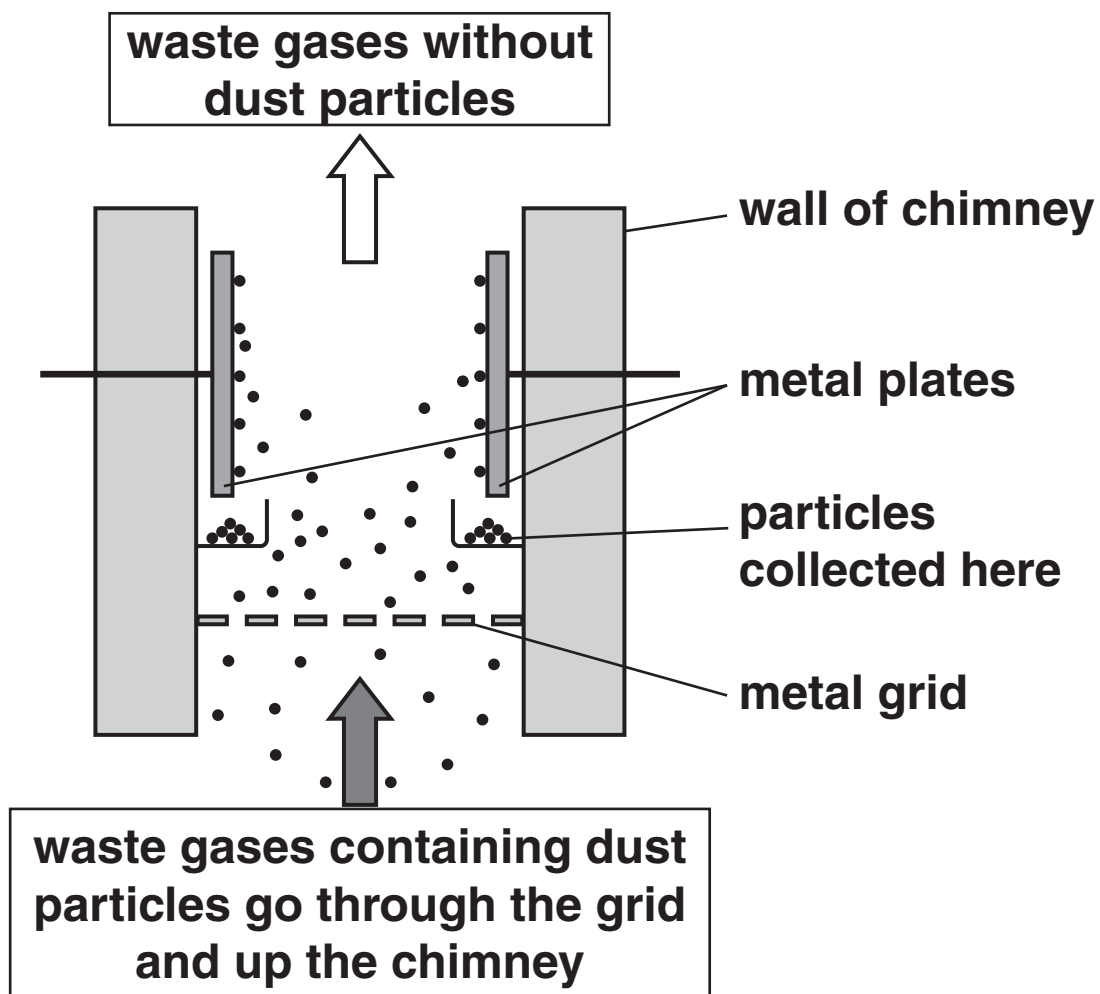



**Describe how the electrostatic precipitator removes dust particles from the waste gases.**

**In your answer, write about**

- voltage (potential difference)**
- charges**
- how the dust particles are removed.**

---

---

---

---

---

**[3]**

**(b) A worker touches a charged object in the dust collector.**

**The worker receives an electric shock.**

**Explain why the worker gets a shock.**

---

---

**[1]**

**[Total: 4]**

### 3 Lucy investigates electrical circuits.

She builds this circuit.

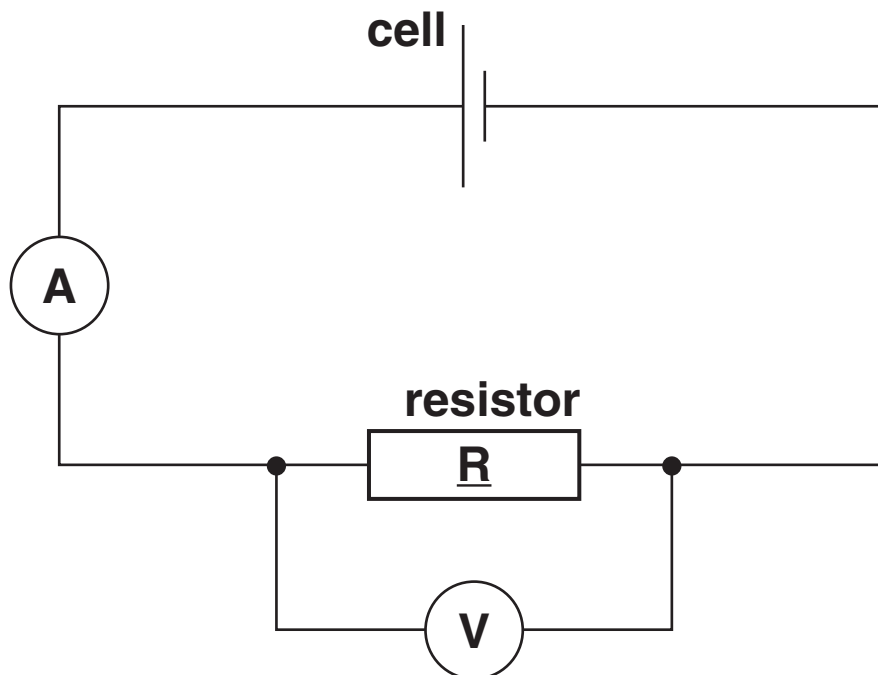

(a) Lucy measures

- the current flowing through the resistor R
- the voltage (potential difference) across the resistor.

Here are her results.

current = 1.5 amps (A)

voltage = 6.0 volts (V)

Calculate the RESISTANCE of the resistor R.

The equations on pages 4–5 may help you.

---

---

---

answer \_\_\_\_\_ ohms ( $\Omega$ ) [2]

(b) Lucy adds another cell to her circuit.

This increases the current in the resistor.

What happens to the voltage (potential difference) across the resistor?

---

---

 [1]

[Total: 3]

4 **Ultrasound is a sound wave with a very high frequency.**

(a) **Ultrasound waves can be shown by a wave diagram.**

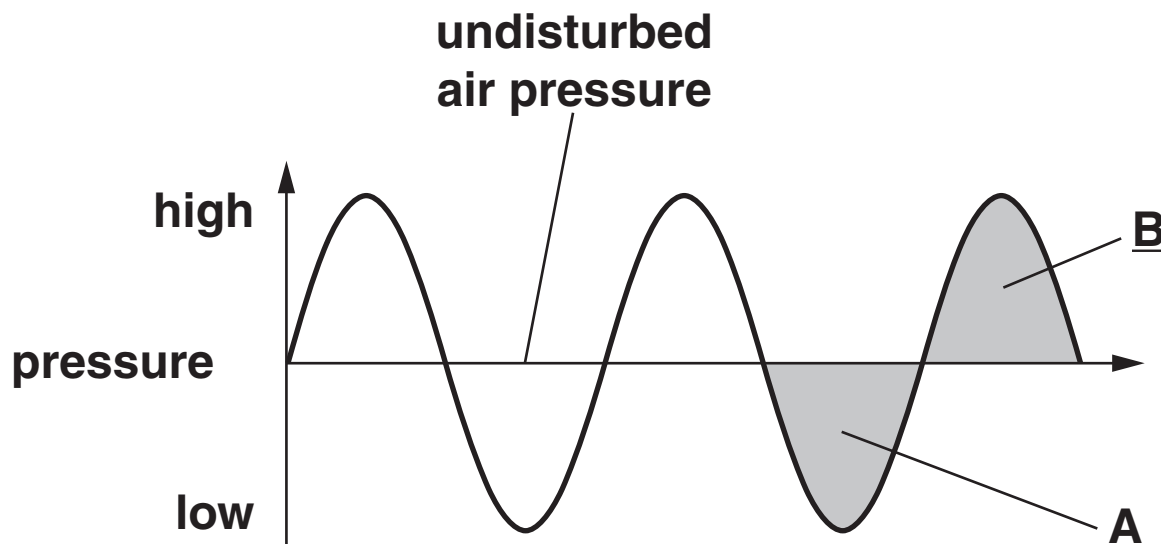

**Part A of the wave is a RAREFACTION. Part B of the wave is a COMPRESSION.**

**Explain what is meant by a COMPRESSION in an ultrasound wave.**

---

---

[1]

**(b) Ultrasound has many uses.**

**Doctors use ultrasound to scan an unborn baby.**

**Complete these sentences about an ultrasound scan.**

**Choose words from the list.**

**DIFFRACTS**

**PICTURES**

**REFLECTS**

**REFRACTS**

**SIGNALS**

**TRANSMITS**

**TRAVELS**

**Doctors put an ultrasound device on the mother.**

**The device \_\_\_\_\_ an ultrasound wave through the mother to the baby.**

**The ultrasound wave \_\_\_\_\_ off the baby.**

**The ultrasound wave then \_\_\_\_\_ back to the surface of the mother's skin.**

**The \_\_\_\_\_ are picked up by a sensor.**

**Then \_\_\_\_\_ of the baby are produced.**

**[3]**

**[Total: 4]**

5 Electricity is produced in a nuclear power station.

The fuel used is uranium.

The uranium releases energy in a CHAIN REACTION.

The diagram shows what happens to a uranium atom.

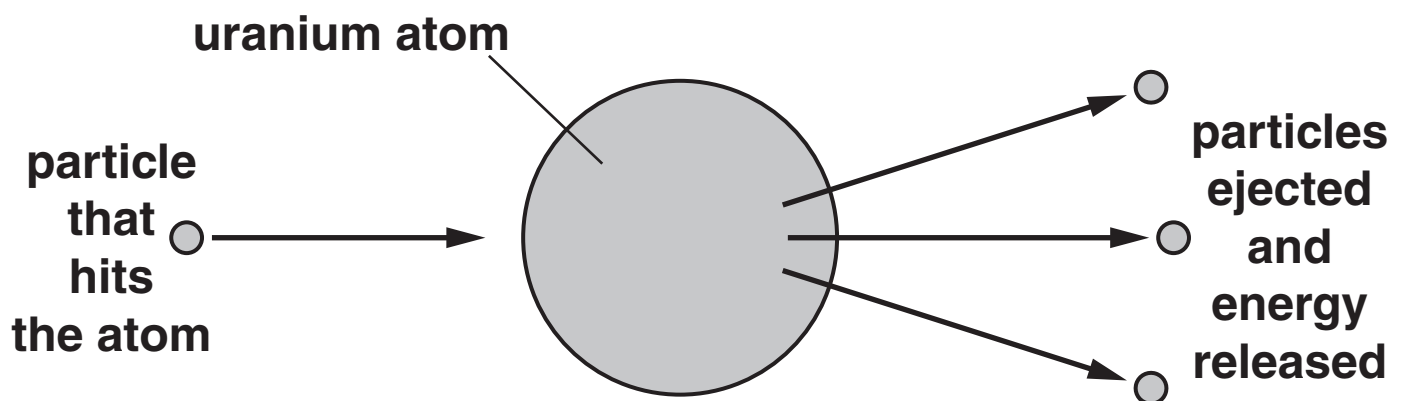

Complete the following sentences about nuclear chain reactions.

The particle that collides with the uranium atom is called a \_\_\_\_\_ .

The part of the atom that the particle collides with is the \_\_\_\_\_ .

The atom then \_\_\_\_\_ , particles are ejected and energy is released. [3]

[Total: 3]

6 This question is about nuclear radiation.



Radioactive elements give out nuclear RADIATION.

One type of nuclear radiation is BETA.

(a) Thallium is a radioactive element.

It has

- a mass number of 207
- an atomic number of 81.

Thallium emits a BETA particle.

A new element is formed.

(i) What is the MASS number of the new element?

\_\_\_\_\_ [1]

(ii) What is the ATOMIC number of the new element?

\_\_\_\_\_ [1]

**(b) Radioactive DATING can be used to find the age of very old rocks.**

**Their age can be found from the ratio of two ELEMENTS in the rocks.**

**Which two elements are used in the radioactive dating of rocks?**

\_\_\_\_\_ and \_\_\_\_\_ [1]

**[Total: 3]**



**SECTION B – MODULE P5**

- 7 (a) Danny shines a ray of light from a ray box through a glass block.

He looks at the path of the light LEAVING the block.

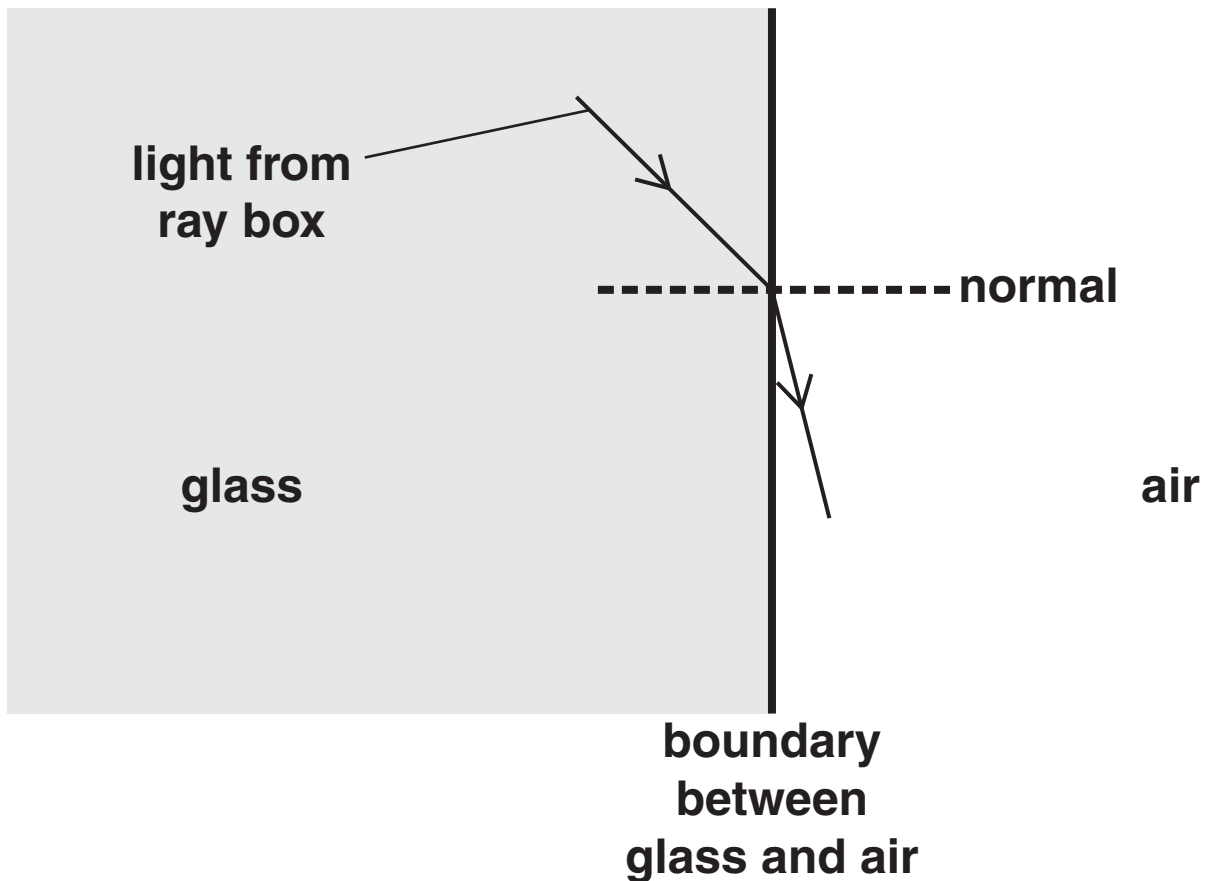

What happens to the speed of light as it passes from glass into air?

\_\_\_\_\_ [1]

**(b) Danny moves the ray box.**

**The angle of incidence,  $i$ , is larger than the critical angle.**

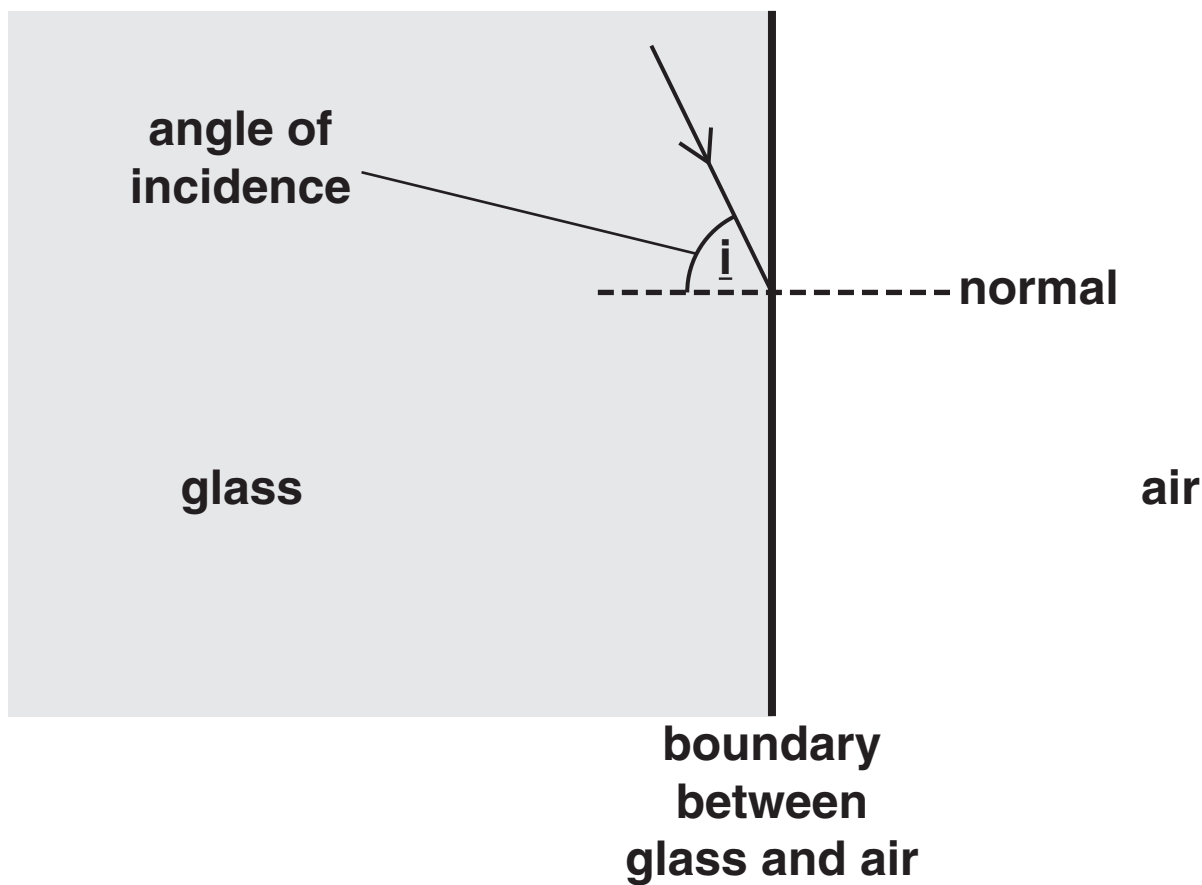

**Complete the diagram to show what happens to the ray of light. [2]**

(c) Danny shines WHITE light towards a prism.

A visible spectrum is formed.

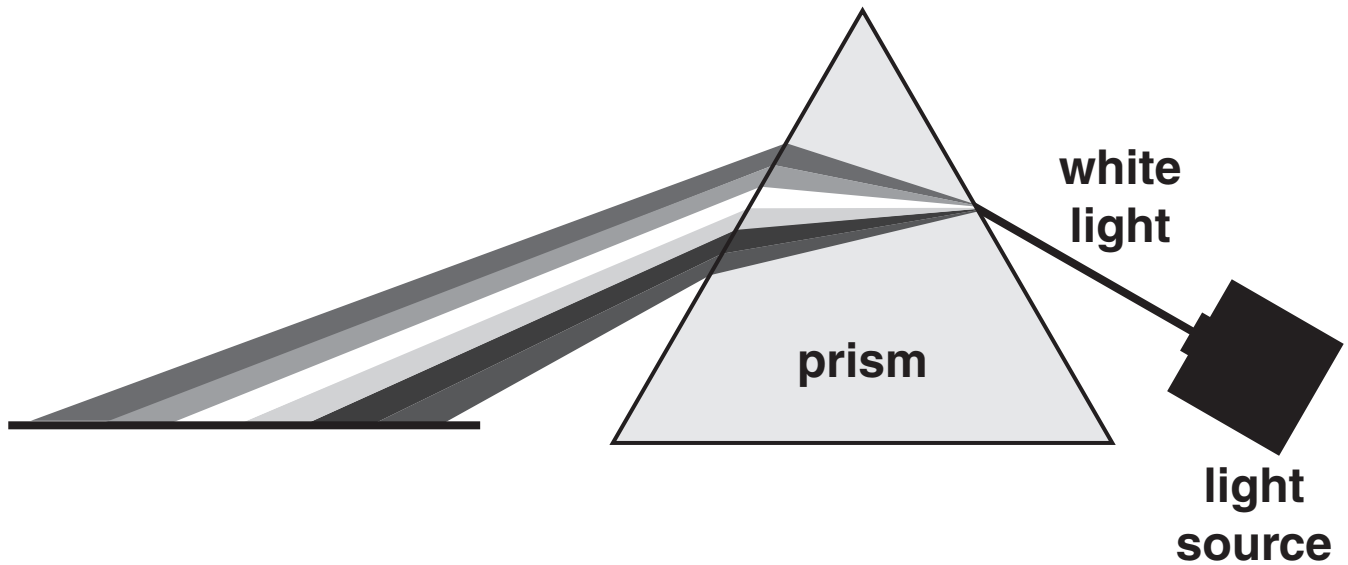

The white light is dispersed into the colours of the spectrum INSIDE THE PRISM.

Explain why.

In your answer, use ideas about

- the wavelength of red and blue light
- the speed of red and blue light INSIDE THE PRISM
- the refractive index for red and blue light.

---

---

---

[3]

[Total: 6]

**8 Artificial satellites orbit the Earth.**

**One use of an artificial satellite is to measure light pollution over Europe.**

**(a) Satellites orbit at different heights above the Earth.**

**(i) A GEOSTATIONARY satellite orbits the Earth 36 000 km above the equator.**

**How long does it take for a geostationary satellite to orbit the Earth?**

**answer \_\_\_\_\_ hours [1]**

**(ii) Another satellite orbits 20 000 km above the Earth.**

**How does this affect the time it takes for this satellite to orbit the Earth?**

\_\_\_\_\_ [1]

**(b) Gravity keeps a satellite in a circular orbit.**

**What is the name of the force that keeps any object moving in a circle?**

**Put a ring around the correct answer.**

**CENTRIFUGAL**

**CENTRIPETAL**

**COUPLE**

**ORBITAL**

**[1]**

**(c) The satellite that took the photograph showing light pollution travels faster in its orbit than a geostationary satellite.**

**What causes it to travel faster?**

\_\_\_\_\_ **[1]**

**[Total: 4]**

9 Sarah drives a train.

The maximum SPEED of her train is 120 km/h.

(a) Speed is a SCALAR quantity. Velocity is a VECTOR quantity.

What is the difference between a scalar quantity and a vector quantity?

\_\_\_\_\_  
\_\_\_\_\_ [1]

(b) Sarah's train is standing at a station.

It then accelerates at  $0.5 \text{ m/s}^2$  for 60 seconds.

(i) Calculate the velocity of the train at the end of 60 seconds.

The equations on pages 4–5 may help you.

\_\_\_\_\_  
\_\_\_\_\_

velocity = \_\_\_\_\_ m/s [2]

**(ii) How far does the train travel during the 60 seconds?**

**The equations on pages 4–5 may help you.**

---

---

**distance travelled = \_\_\_\_\_ m [2]**

**[Total: 5]**

**10 As a cannon ball leaves a cannon, the cannon moves backwards.**

**Explain why and describe the motion of the cannon.**

**In your answer use ideas about**

- **mass**
- **velocity**
- **momentum.**

---

---

---

---

---

---

---

---

**[3]**

**[Total: 3]**



**11 Debbie wears polarising sunglasses in bright light.**

**They reduce the amount of light passing through to her eyes.**

**The light passing through is PLANE POLARISED.**

**(a) What type of wave can be plane polarised?**

\_\_\_\_\_ [1]

**(b) What is the difference between unpolarised light waves and polarised light waves?**

\_\_\_\_\_  
\_\_\_\_\_ [1]

**[Total: 2]**

**SECTION C – MODULE P6**

**12 This question is about electricity.**

**Paula connects the following circuit.**

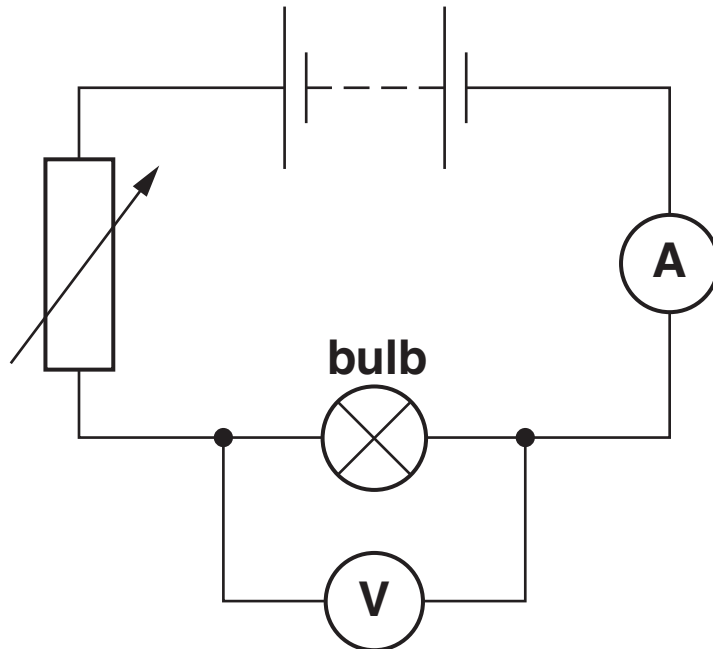

**(a) When the current is 2.5 A, the resistance of the bulb is  $3.0\ \Omega$ .**

**Calculate the voltage across the bulb.**

**The equations on pages 4–5 may help you.**

---

---

**answer \_\_\_\_\_ V**

**[2]**

**(b) She collects more results and draws a voltage-current graph.**

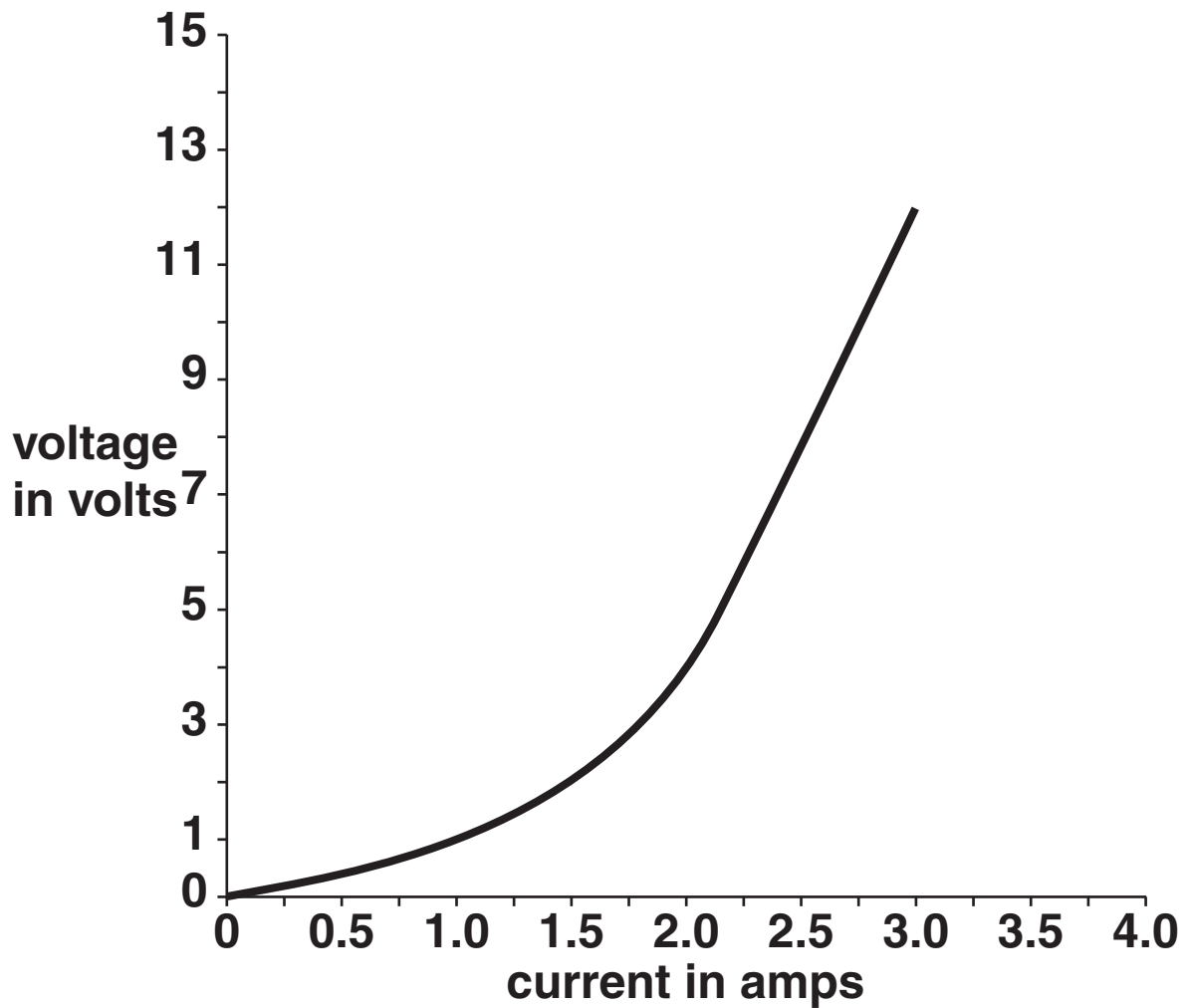

**(i) What does the shape of the voltage-current graph tell you about the resistance?**

\_\_\_\_\_ [1]

**(ii) Explain the shape of the voltage-current graph.**

**In your answer write about**

- **electrons**
- **atoms**
- **resistance**
- **temperature.**

---

---

---

---

---

---

---

---

**[3]**

**[Total: 6]**

**13 This question is about magnetic fields and forces.**

**(a) (i) John passes a wire through a card.**

**He connects the wire to a battery.**

**Look at the diagram opposite.**

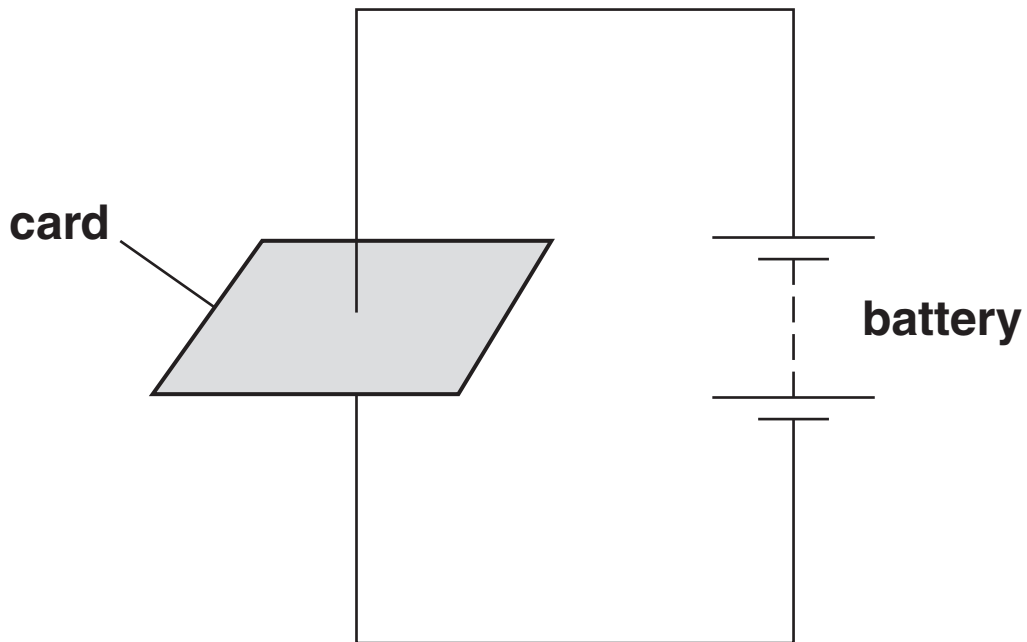

He sprinkles iron filings onto the card to show the shape of the magnetic field.

Which is the shape of the magnetic field made by the wire?

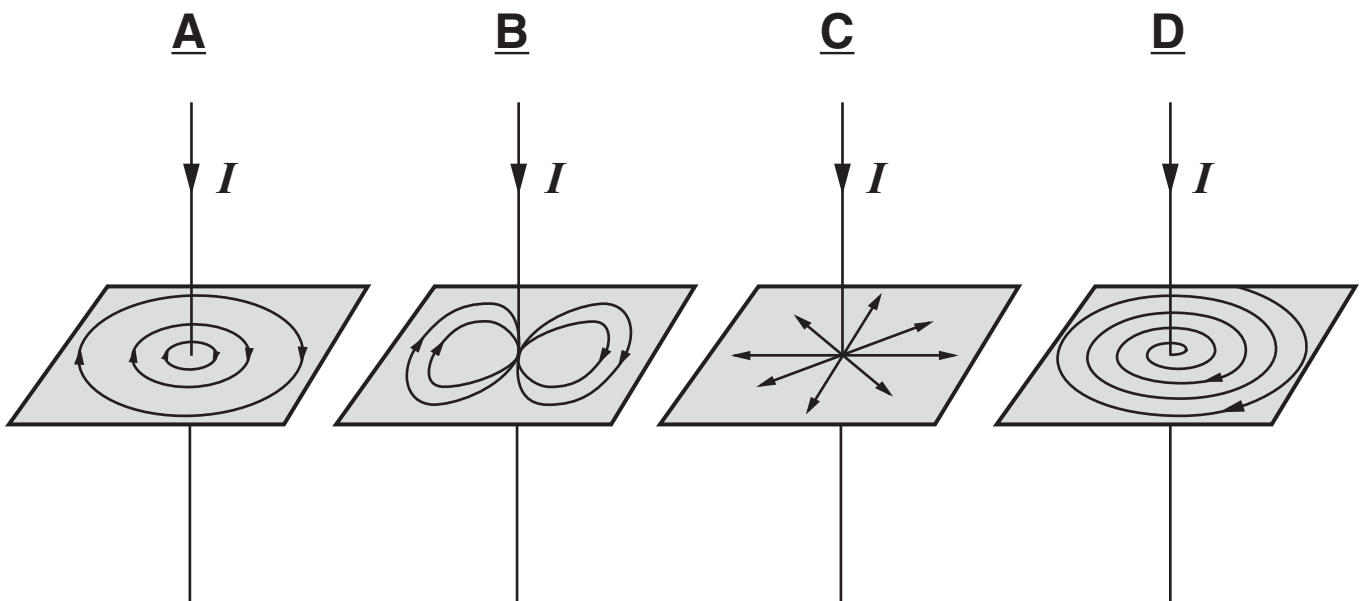

Choose from: A B C D

answer \_\_\_\_\_

[1]

(ii) He puts the wire between the poles of a magnet.

Look at the diagram.

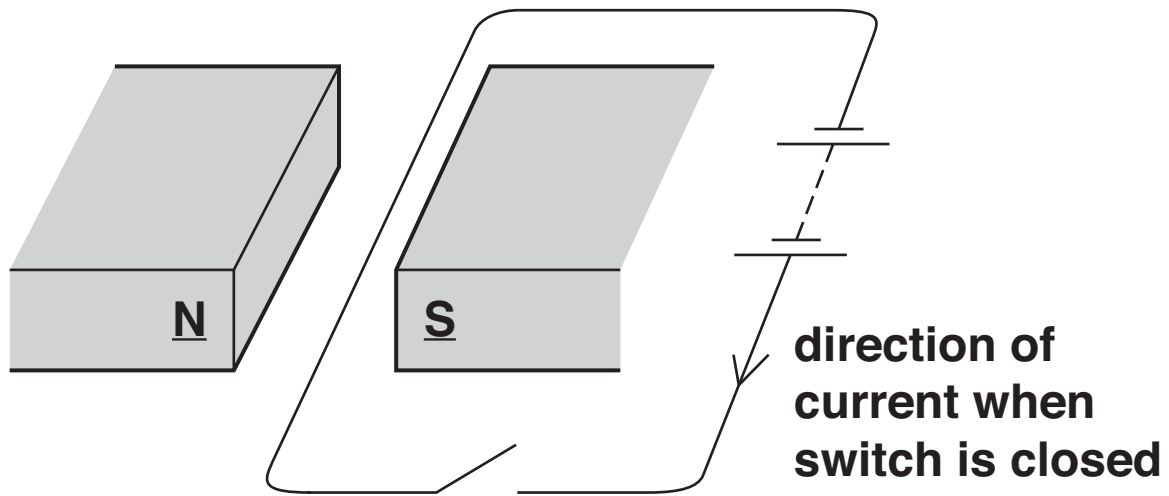

When he closes the switch, there is a current in the wire.

The wire moves.

Use Fleming's left hand rule to predict the direction of motion.

Which way does the wire move?

Put a ring around the correct answer.

TOWARDS S

TOWARDS N

UPWARDS

DOWNWARDS

[1]

**(b) The diagram shows part of a simple electric motor.**

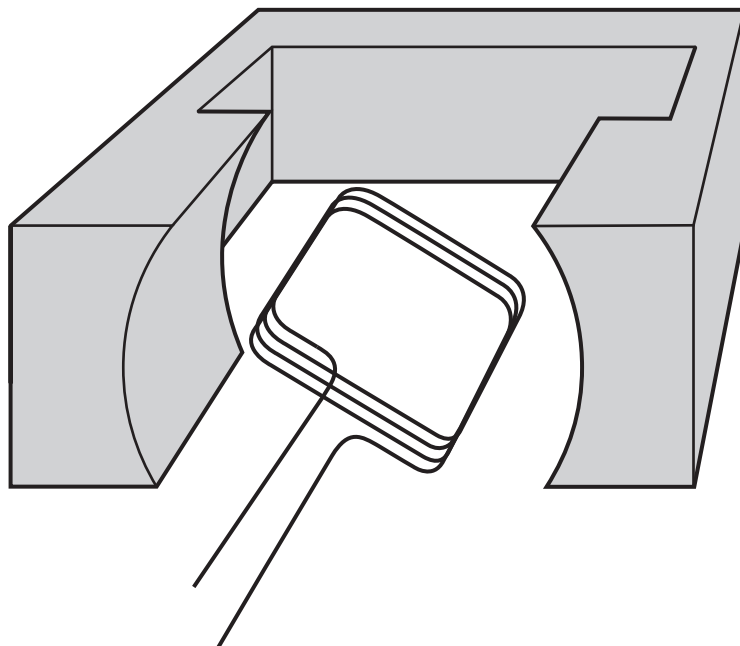

**The current is increased.**

**The motor spins faster.**

**Suggest TWO OTHER ways of making the motor spin faster.**

**1** \_\_\_\_\_

**2** \_\_\_\_\_ **[2]**

**[Total: 4]**

14 This question is about transformers.

Look at the diagram of a transformer.

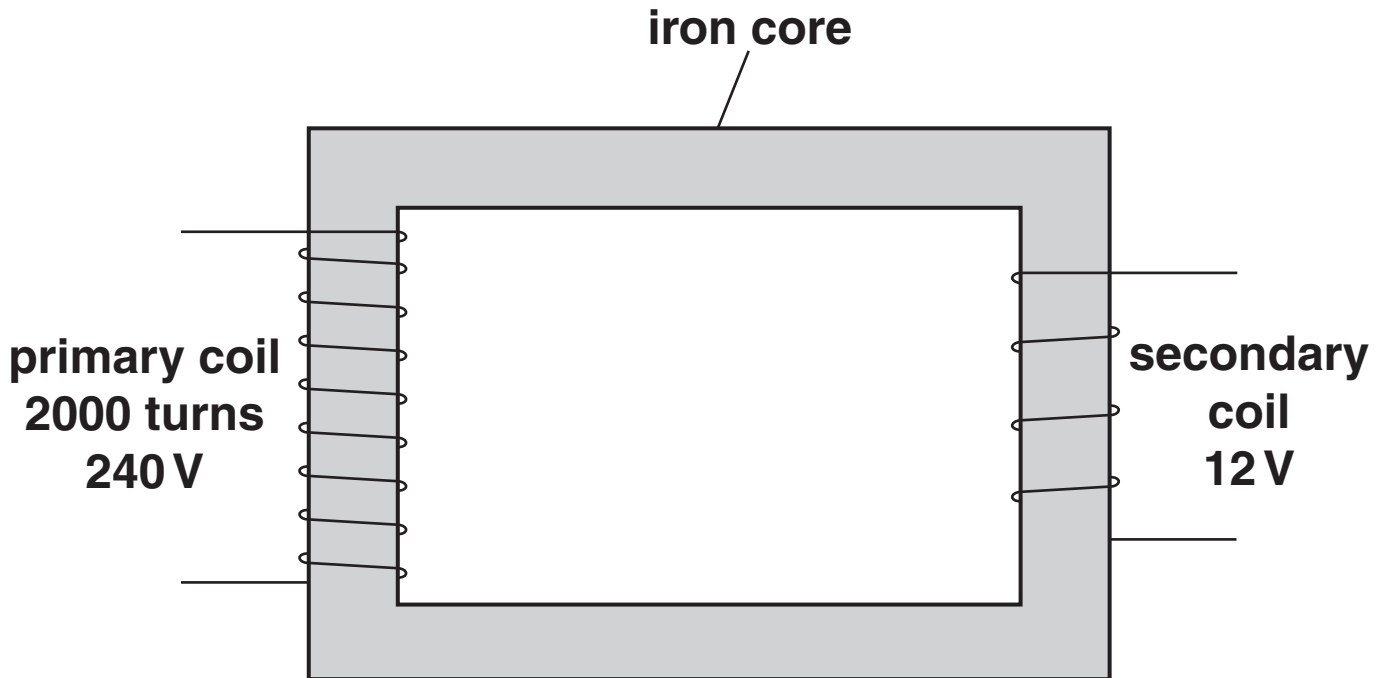

Jenny has a 12V lamp.

She wants to use it from the 240V mains.

The transformer she uses has 2000 turns on the primary coil.

Calculate the number of turns on the secondary coil.

The equations on pages 4–5 may help you.

---

---

---

---

answer \_\_\_\_\_ turns

[2]  
[Total: 2]



**BLANK PAGE**

**15 Chris needs to change the output from a transformer to DC.**

**He uses four diodes.**

**They are connected in the following circuit.**

**It is called a bridge rectifier circuit.**

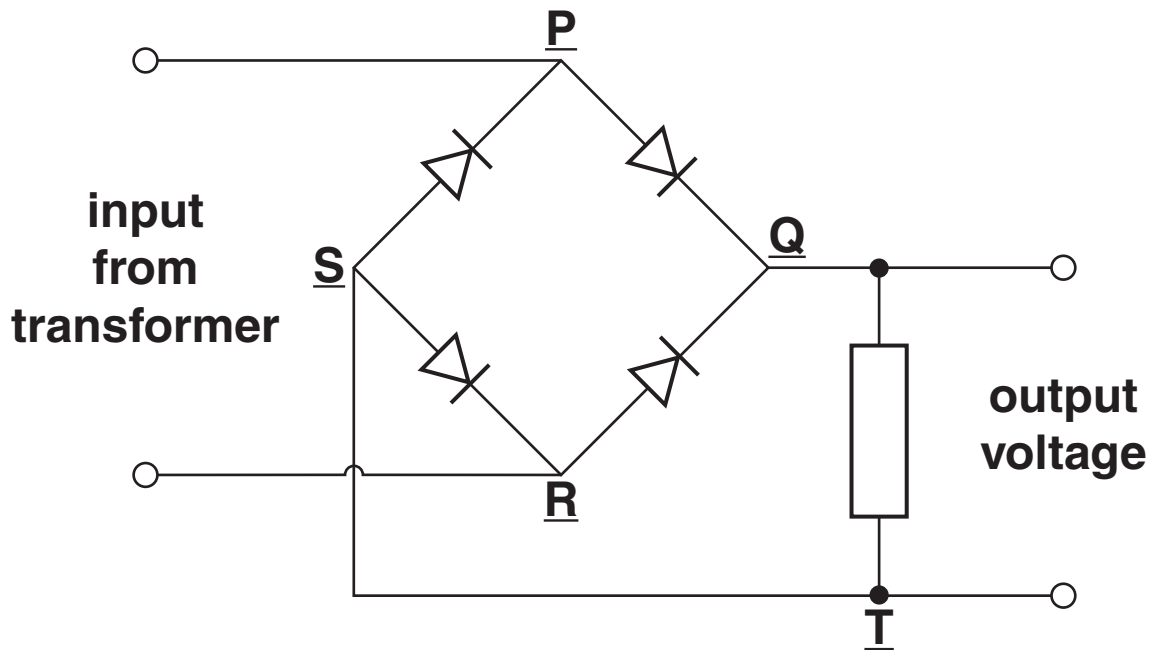

(a) The graph shows the input to the bridge rectifier.

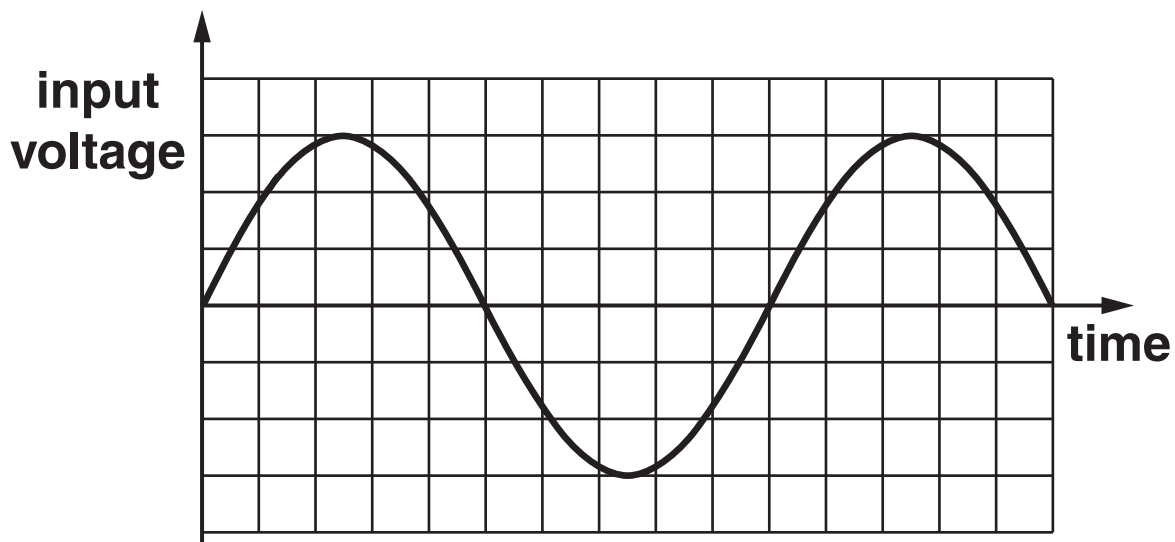

On the axis below, sketch the output that you would expect.

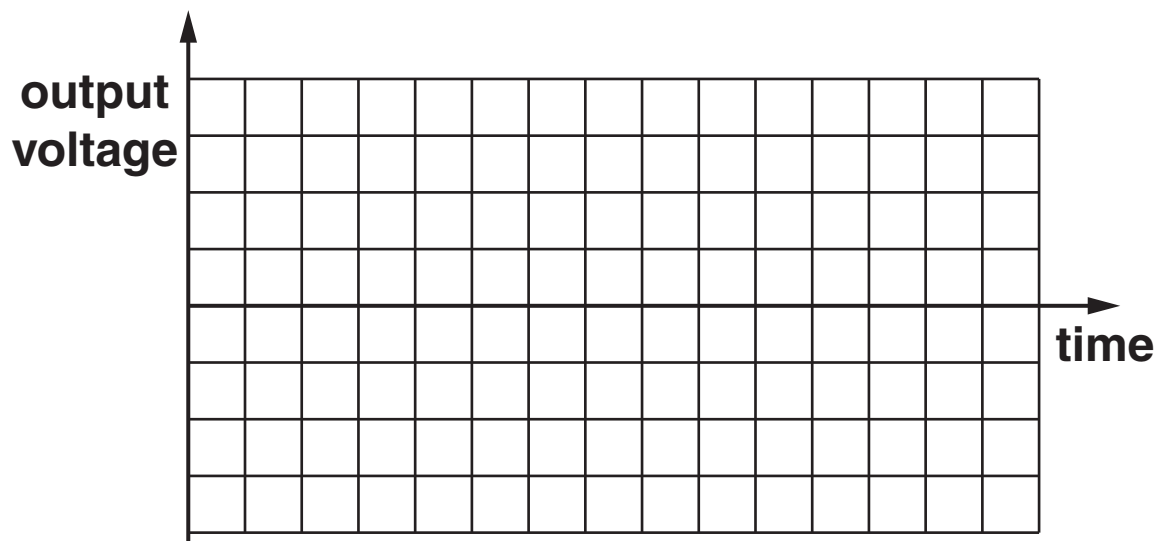

[2]

**(b) Explain how the bridge rectifier produces direct current.**

**In your answer you should clearly describe the direction of the current through the bridge rectifier.**

---

---

---

---

---

---

---

---

---

---

**[2]**

**(c) In some circuits, scientists connect a CAPACITOR to the output of the bridge rectifier.**

**Explain why.**

---

---

---

---

---

**[1]**

**[Total: 5]**

16 This question is about logic gates.

The diagram shows the symbol for a NOR gate.

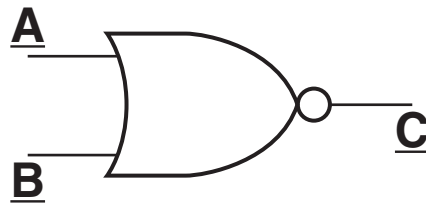

(a) Complete the truth table for a NOR gate.

<u>A</u>	<u>B</u>	<u>C</u>
0	0	
0	1	
1	0	
1	1	

[1]

(b) Fred wants to use the logic gate to control a powerful lamp.

He uses a relay to control the lamp.

Describe how a relay allows him to switch on a powerful lamp using a logic gate.

---

---

---

---

[2]

[Total: 3]

END OF QUESTION PAPER

**BLANK PAGE**

**BLANK PAGE**



## **Copyright Information**

**OCR is committed to seeking permission to reproduce all third-party content that it uses in its assessment materials. OCR has attempted to identify and contact all copyright holders whose work is used in this paper. To avoid the issue of disclosure of answer-related information to candidates, all copyright acknowledgements are reproduced in the OCR Copyright Acknowledgements Booklet. This is produced for each series of examinations, is given to all schools that receive assessment material and is freely available to download from our public website ([www.ocr.org.uk](http://www.ocr.org.uk)) after the live examination series.**

**If OCR has unwittingly failed to correctly acknowledge or clear any third-party content in this assessment material, OCR will be happy to correct its mistake at the earliest possible opportunity.**

**For queries or further information please contact the Copyright Team, First Floor, 9 Hills Road, Cambridge CB2 1PB.**

**OCR is part of the Cambridge Assessment Group; Cambridge Assessment is the brand name of University of Cambridge Local Examinations Syndicate (UCLES), which is itself a department of the University of Cambridge.**