

Candidate forename		Candidate surname	
-----------------------	--	----------------------	--

Centre number						Candidate number				
------------------	--	--	--	--	--	---------------------	--	--	--	--

**OXFORD CAMBRIDGE AND RSA EXAMINATIONS
GENERAL CERTIFICATE OF SECONDARY EDUCATION**

B651/01

GATEWAY SCIENCE

PHYSICS B

Unit 1 Modules P1 P2 P3 (Foundation Tier)

WEDNESDAY 19 JANUARY 2011: Morning

DURATION: 1 hour

SUITABLE FOR VISUALLY IMPAIRED CANDIDATES

**Candidates answer on the question paper.
A calculator may be used for this paper.**

OCR SUPPLIED MATERIALS:

None

OTHER MATERIALS REQUIRED:

Pencil

Ruler (cm/mm)

READ INSTRUCTIONS OVERLEAF

INSTRUCTIONS TO CANDIDATES

- **Write your name, centre number and candidate number in the boxes on the first page. Please write clearly and in capital letters.**
- **Use black ink. Pencil may be used for graphs and diagrams only.**
- **Read each question carefully. Make sure you know what you have to do before starting your answer.**
- **Write your answer to each question in the space provided. Additional paper may be used if necessary but you must clearly show your candidate number, centre number and question number(s).**
- **Answer ALL the questions.**

INFORMATION FOR CANDIDATES

- **The number of marks is given in brackets [] at the end of each question or part question.**
- **A list of physics equations is printed on page three.**
- **The total number of marks for this paper is 60.**

EQUATIONS

$$\text{efficiency} = \frac{\text{useful energy output}}{\text{total energy input}}$$

$$\text{wave speed} = \text{frequency} \times \text{wavelength}$$

$$\text{power} = \text{voltage} \times \text{current}$$

$$\text{energy (kilowatt hours)} = \text{power (kW)} \times \text{time (h)}$$

$$\text{speed} = \frac{\text{distance}}{\text{time taken}}$$

$$\text{acceleration} = \frac{\text{change in speed}}{\text{time taken}}$$

$$\text{force} = \text{mass} \times \text{acceleration}$$

$$\text{work done} = \text{force} \times \text{distance}$$

$$\text{power} = \frac{\text{work done}}{\text{time}}$$

Answer ALL the questions.

SECTION A – MODULE P1

1 This question is about heating ice.

The ice is warmed. It turns into water.

The water is heated.

Look at the graph.

It shows what happens when ice is warmed, and then the water produced is heated.

temperature

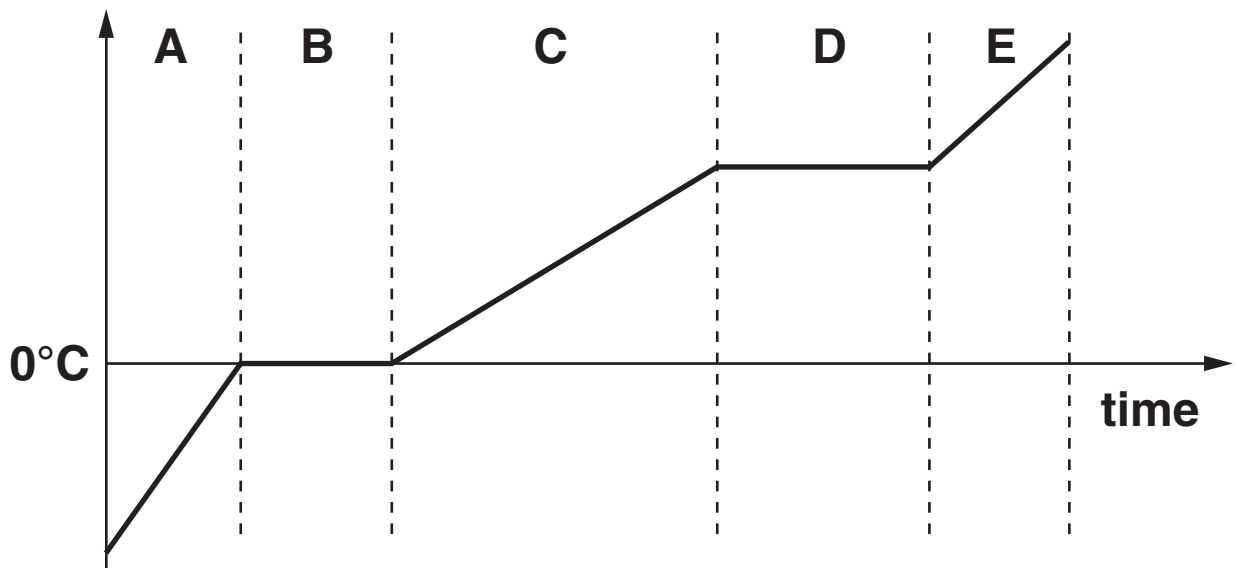

(a) (i) Which letter shows where the ice is MELTING?

Choose from

A B C D E

answer _____

[1]

(ii) Which letter shows where the water is BOILING?

Choose from

A B C D E

answer _____ [1]

(b) Ice melts when it is heated.

Complete the sentence about heat.

Heat is a form of _____ . [1]

[Total: 3]

2 Three methods of keeping houses warm are

- **having double glazed windows**
- **putting foam in cavity-walls**
- **using layers of mineral wool in the loft.**

All three methods work in the same way.

The materials they are made from have a substance TRAPPED in them.

Complete the sentences.

The three methods work because the materials all contain trapped _____ in them.

The trapped substance is a good

_____ .

[2]

[Total: 2]

3 Ravi has a fire in his house.

He uses wood as a fuel for the fire.

The fire transfers the STORED ENERGY in the wood into HEAT ENERGY in the room.

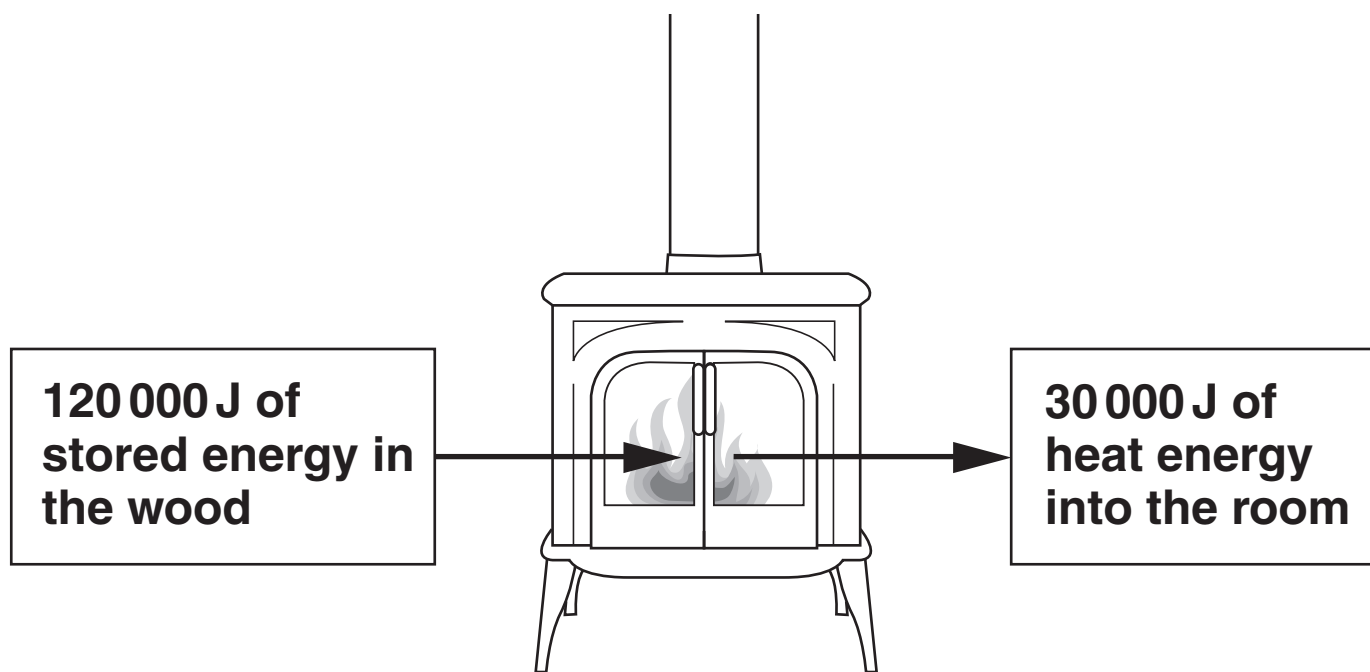

(a) For every 120 000 J of stored energy in the wood 30 000 J of heat energy goes into the room.

Calculate how EFFICIENT the fire is at transferring heat energy to the room.

The equations on page 3 may help you.

answer _____

[2]

(b) The air near the fire becomes hot.

What happens to this hot air?

_____ [1]

(c) The fire gives out INFRARED radiation into the room.

What happens to the infrared radiation when it reaches a shiny surface?

_____ [1]

[Total: 4]

BLANK PAGE

4 Microwave ovens cook food quickly.

**glass oven
door with
metal mesh**

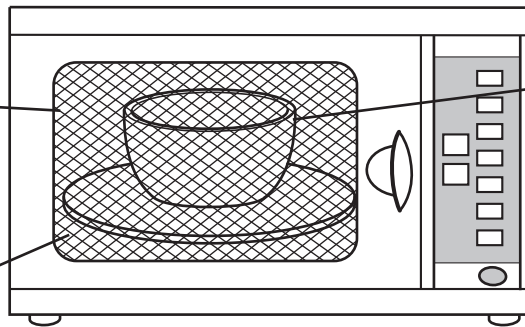

**plastic
container
inside
oven**

**shiny metal
sides inside
oven**

Asif cooks some food using the microwave oven.

He puts the food in a plastic container.

Look at the statements about microwave cooking.

- **the microwaves do not penetrate to the centre of the food**
- **plastic and glass containers are often used in microwave cooking**
- **the glass in the door has a mesh of metal in it**
- **to stop microwaves escaping there must be no gaps in the oven**

Use these statements to describe how the food is cooked safely in the microwave oven.

[3]

[Total: 3]

5 (a) TV signals are transmitted using TWO types of signal.

(i) One type of signal is ANALOGUE.

Analogue signals are being replaced by the other type of signal.

What is the name of the other TYPE of signal?

Choose from

DIGITAL

INFRARED

MORSE CODE

RADIO

answer _____ [1]

(ii) This type of signal has only two values, 1 and 0.

How is an ANALOGUE signal different?

_____ [1]

(b) Look at the diagram of a satellite dish.

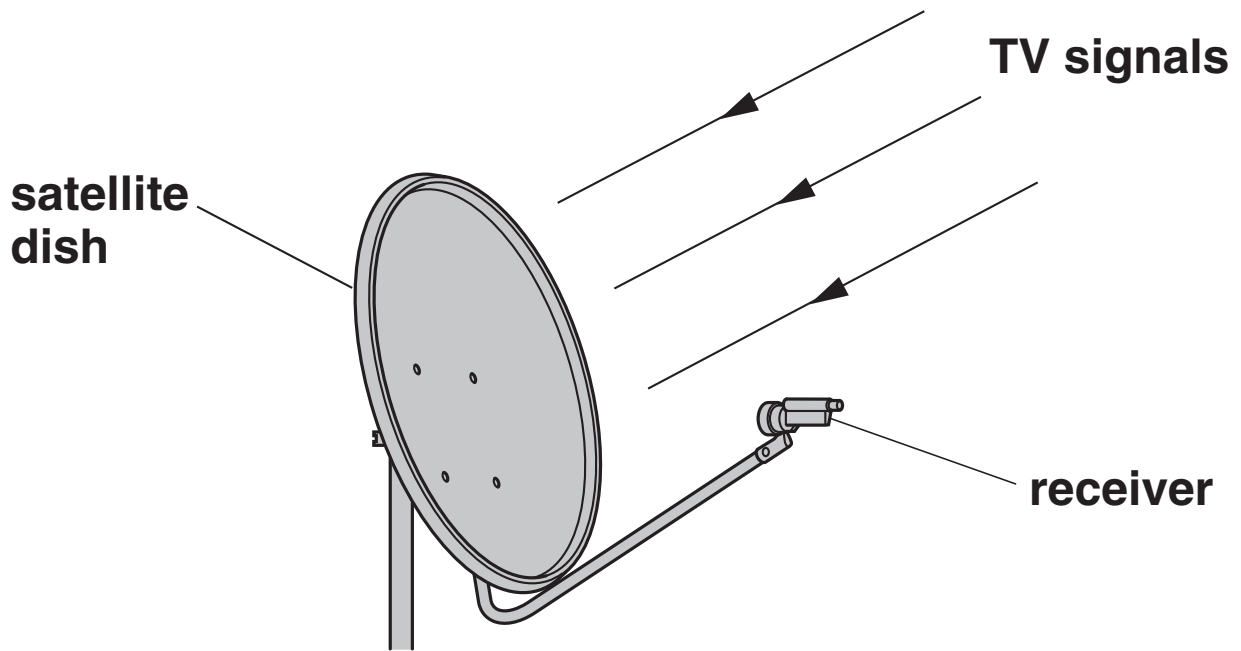

The TV signals reach the satellite dish. They are then focused on the receiver.

How do the signals get from the dish to the receiver?

Choose from

DIFFRACTION

INTERFERENCE

REFRACTION

REFLECTION

answer _____ [1]

- (c) (i) Electromagnetic waves are used in WIRELESS communications.

Which statement about the SPEED of electromagnetic waves in space is correct?

Put a tick (✓) in ONE box next to the correct statement.

electromagnetic waves are slower than sound waves

electromagnetic waves all travel at the same speed

electromagnetic waves with high frequency travel faster

electromagnetic waves with low frequency travel faster

[1]

- (ii) Wireless communication means no wires are used.

Write down one OTHER advantage of using wireless communication.

_____ [1]

(iii) Signals can be sent using a flashing light.

This method was first used many years ago.

This method improved communications.

How did the use of light signals improve communications?

[1]

[Total: 6]

6 Earthquakes produce SHOCK WAVES.

The shock waves travel through the Earth.

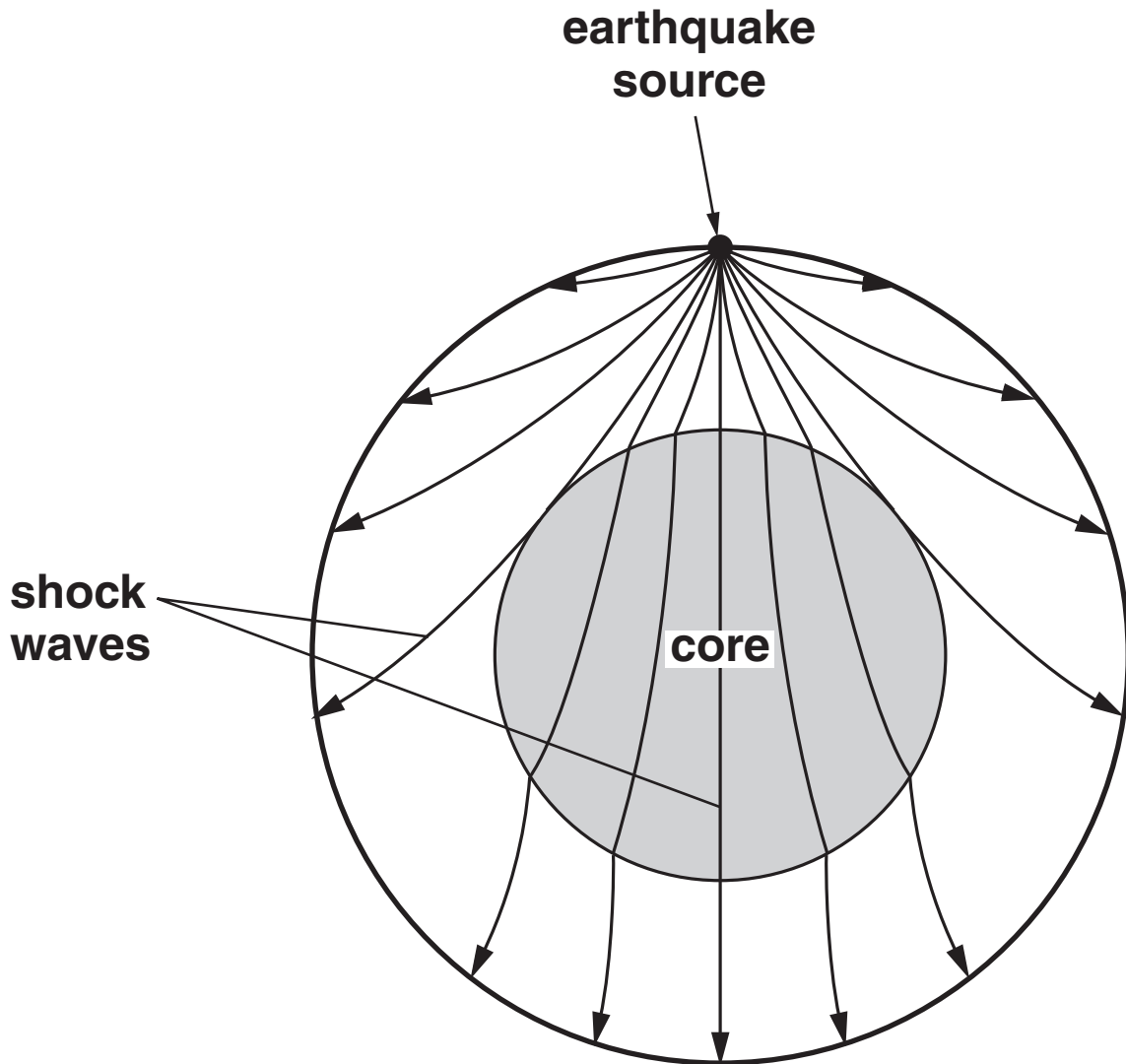

(a) What do the shock waves do to the EARTH'S SURFACE?

[1]

(b) Write down the name of the INSTRUMENT that scientists use to detect Earthquakes.

_____ [1]

[Total: 2]

SECTION B – MODULE P2

7 This question is about using energy from the Sun.

(a) Finish the sentences by choosing the BEST words from this list.

Each word may be used ONCE, MORE THAN ONCE or NOT AT ALL.

ELECTRICITY

HEAT

LIGHT

NUCLEAR

PUMP

SOLAR CELL

SOUND

TURBINE

The Sun transfers energy to the Earth as

_____ and _____ .

A photocell transfers _____ into

_____ .

The Sun produces convection currents in the air which cause wind.

The wind can be used to drive a

_____ .

[4]

(b) Look at the diagram. It shows a room with a large south facing window.

It is daytime.

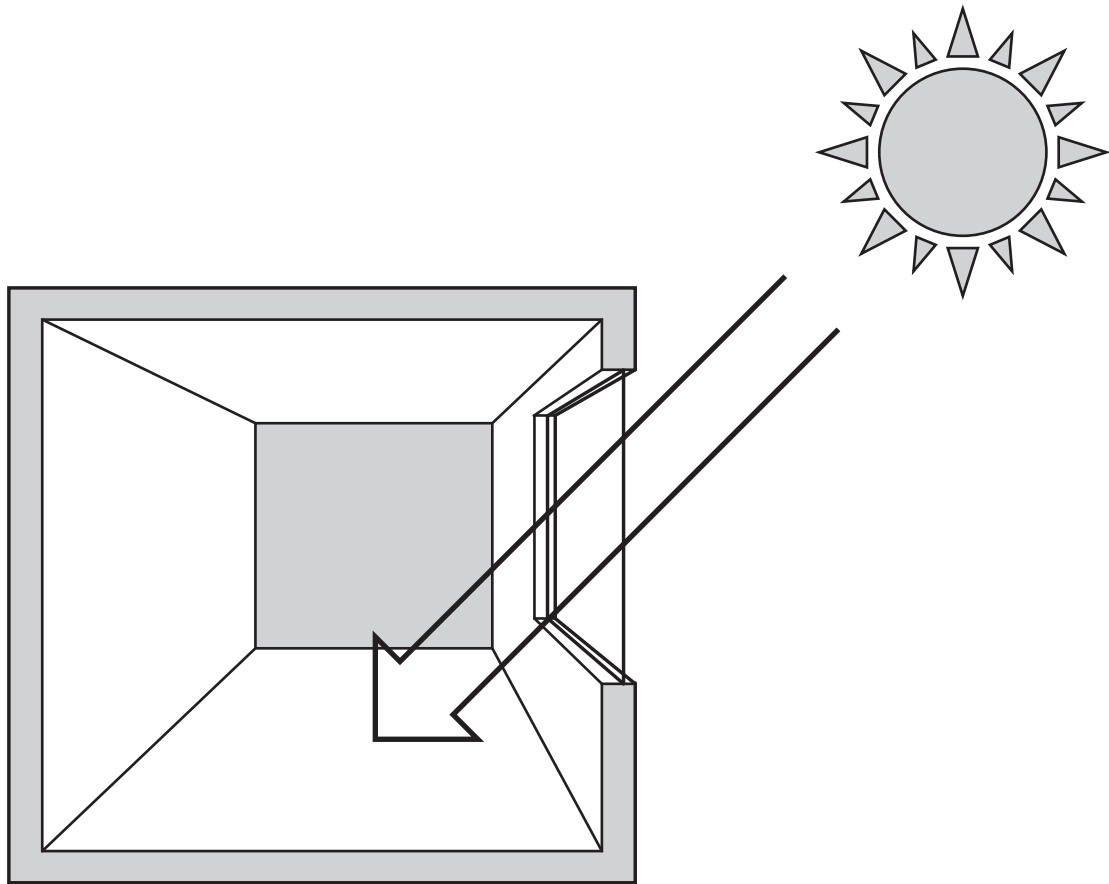

The house uses PASSIVE SOLAR HEATING.

Passive solar heating keeps the room warm during the night.

Describe how this works.

In your answer, write about what happens during the day and what happens at night.

During the day _____

At night _____

_____ [2]

[Total: 6]

8 Power stations generate electricity.

Most power stations burn a FUEL to produce heat.

(a) Write down the name of a NON-RENEWABLE fuel that is used in power stations.

_____ [1]

(b) Write down the name of a RENEWABLE fuel that is used in power stations.

_____ [1]

(c) Nuclear power stations produce waste.

Finish the sentence.

The waste from a nuclear power station is harmful

because it is _____ .[1]

(d) Electricity costs 12p per kilowatt-hour.

Brian watches television for 5 hours.

His television has a power rating of 0.12 kW.

Calculate the cost of the energy supplied.

answer _____ pence [2]

[Total: 5]

9 Viking 1 was sent to orbit Mars in 1975.

Viking 1 was an UNMANNED spacecraft.

There are plans to send a MANNED spacecraft to Mars.

(a) State two essential supplies MANNED spacecraft must carry that UNMANNED spacecraft do not.

_____ and

_____ [2]

(b) Unmanned spacecraft can send back useful information about a planet.

One example is a photograph of the surface of the planet.

What other information about a planet can an UNMANNED spacecraft send back?

_____ [1]

- (c) The comet Tempel 1 was photographed six minutes before it collided with an unmanned spacecraft.



- (i) Finish the sentence.

A comet is mainly made of

_____ and

_____.

[1]

- (ii) Comets and asteroids are examples of NEAR EARTH OBJECTS (NEOs).

Explain what is meant by a Near Earth Object.

_____ [1]

[Total: 5]

10 (a) The Big Bang theory explains how the Universe began.

Write about the Big Bang theory.

In your answer, use ideas about

- what is meant by the Big Bang**
- how the Universe is changing today.**

[2]

(b) Scientists examined samples of rock from the Moon.

They found that

- 1. The rocks are similar to Earth rock, but not exactly the same.**
- 2. The Moon does not have an iron core.**
- 3. The Moon has a lot of material that formed quickly at high temperatures.**

Describe how scientists think the Moon was formed.

[2]

[Total: 4]

SECTION C – MODULE P3

11 Alice jumps out of an aeroplane.



(a) She falls for a few seconds.

(i) What happens to Alice's **SPEED** just after she jumps out of the aeroplane?

_____ [1]

(ii) What type of **ENERGY** does Alice lose as she falls?

_____ [1]

(iii) What **FORCE** causes Alice to fall towards the ground?

_____ [1]

(b) Alice reaches her highest speed. What could she do to **INCREASE** this speed?

_____ [1]

(c) Alice opens her parachute.

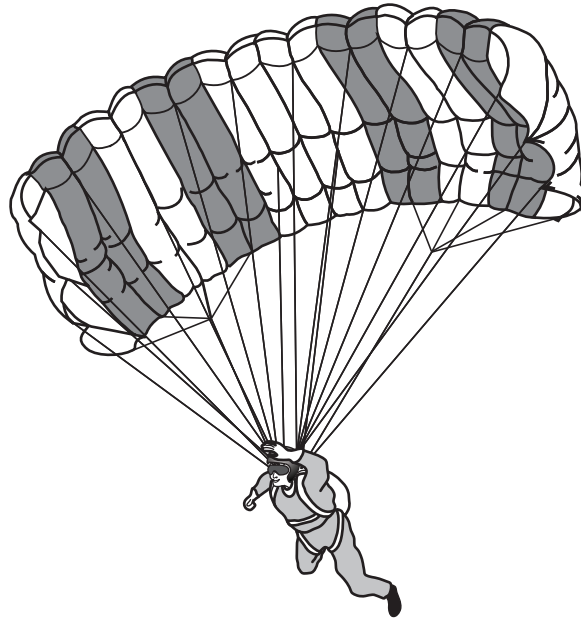

The opening parachute causes a large force.

This large force slows her down.

(i) Write down the name of this FORCE.

_____ [1]

(ii) What is the DIRECTION of this force?

_____ [1]

[Total: 6]

12 Look at the picture.

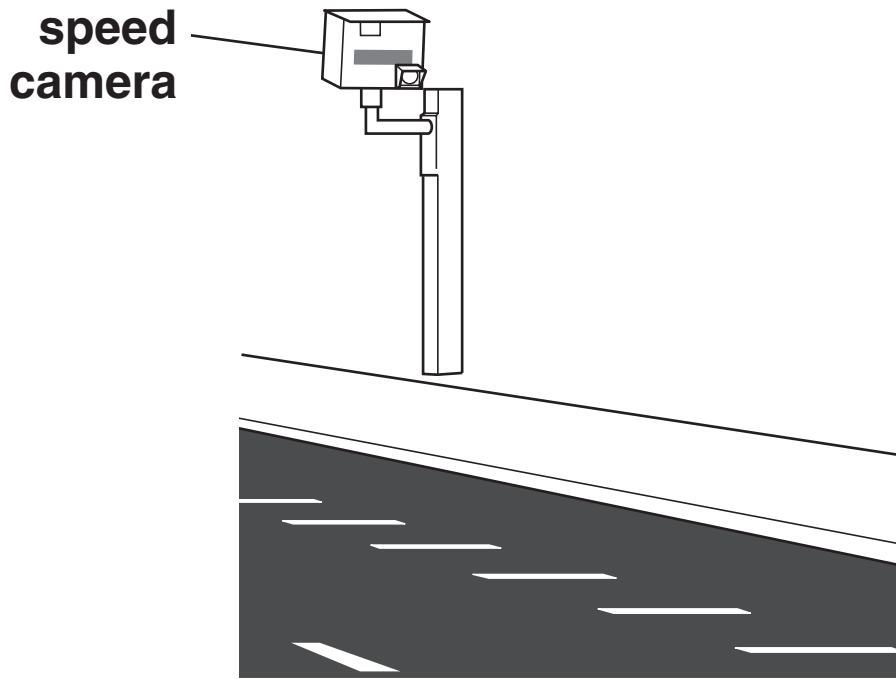

A car drives along the road.

Describe how the speed of the car is measured by the speed camera.

[3]

[Total: 3]

13 Cars have safety features. These features can reduce injuries in a crash.

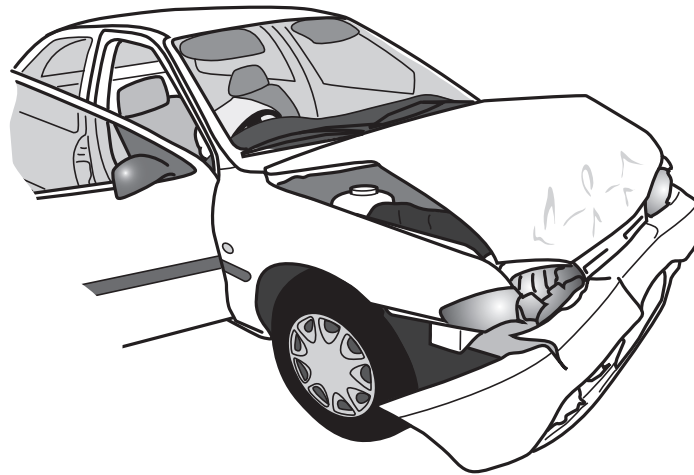

(a) Energy is absorbed by the brakes before a crash.

The work done by the brakes is 50 000 J. The brakes are on for 2 s.

Calculate the average POWER of the brakes.

The equations on page 3 may help you.

answer _____ watts

[2]

(b) The seatbelts absorb energy in the crash.

(i) The seatbelts must be replaced after the crash.

Explain why.

_____ [1]

(ii) Seatbelts are an example of a safety feature.

Seatbelts ABSORB energy in a crash.

Write down one OTHER safety feature that absorbs energy in a crash.

_____ [1]

(c) Some safety features do NOT absorb energy in a crash.

Write down one safety feature that does NOT absorb energy but does protect the driver in a crash.

_____ [1]

[Total: 5]

14 Dave drives his car.

The car accelerates. Look at the diagram.

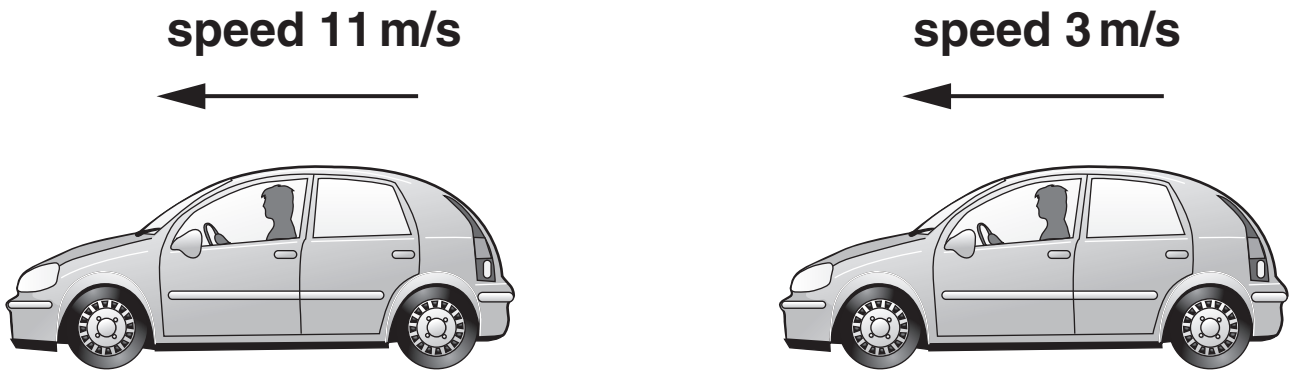

It takes Dave 2 s to accelerate from 3 m/s to 11 m/s.

(a) Calculate the **ACCELERATION** of the car.

The equations on page 3 may help you.

answer _____ m/s² [2]

(b) The car has kinetic energy when it moves.

What happens to the car's kinetic energy when its SPEED doubles?

Choose from

kinetic energy HALVES

kinetic energy STAYS THE SAME

kinetic energy DOUBLES

kinetic energy QUADRUPLES

answer _____ [1]

(c) The mass of Dave's car is 1000 kg.

Dave attaches a caravan to his car. This increases the mass to 2000 kg.

He drives again at 11 m/s.

Look at the diagram.

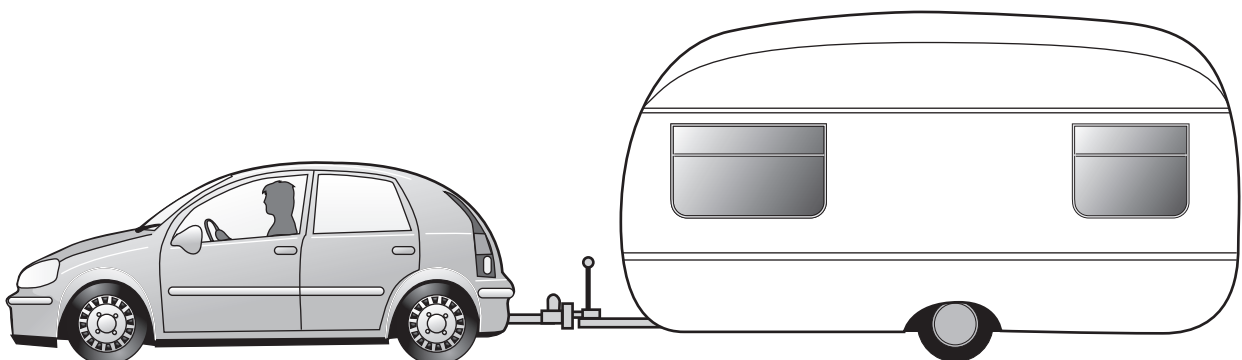

mass = 2000 kg

speed = 11m/s

- (i) What happens to the total kinetic energy when the MASS doubles?

Choose from

kinetic energy HALVES

kinetic energy STAYS THE SAME

kinetic energy DOUBLES

kinetic energy QUADRUPLES

answer _____ [1]

- (ii) Dave drives his car with the caravan attached.

He finds that the acceleration is REDUCED.

Suggest why.

_____ [1]

- (iii) The caravan must have its own brakes.

When Dave presses the car's brake pedal, the car brakes AND the caravan brakes work together.

Suggest why the caravan also needs brakes.

_____ [1]

[Total: 6]

END OF QUESTION PAPER

Copyright Information

OCR is committed to seeking permission to reproduce all third-party content that it uses in its assessment materials. OCR has attempted to identify and contact all copyright holders whose work is used in this paper. To avoid the issue of disclosure of answer-related information to candidates, all copyright acknowledgements are reproduced in the OCR Copyright Acknowledgements Booklet. This is produced for each series of examinations and is freely available to download from our public website (www.ocr.org.uk) after the live examination series.

If OCR has unwittingly failed to correctly acknowledge or clear any third-party content in this assessment material, OCR will be happy to correct its mistake at the earliest possible opportunity.

For queries or further information please contact the Copyright Team, First Floor, 9 Hills Road, Cambridge CB2 1GE.

OCR is part of the Cambridge Assessment Group; Cambridge Assessment is the brand name of University of Cambridge Local Examinations Syndicate (UCLES), which is itself a department of the University of Cambridge.