

|                     |  |  |  |  |  |                  |  |  |  |  |
|---------------------|--|--|--|--|--|------------------|--|--|--|--|
| Centre Number       |  |  |  |  |  | Candidate Number |  |  |  |  |
| Surname             |  |  |  |  |  |                  |  |  |  |  |
| Other Names         |  |  |  |  |  |                  |  |  |  |  |
| Candidate Signature |  |  |  |  |  |                  |  |  |  |  |

|                     |      |
|---------------------|------|
| For Examiner's Use  |      |
| Examiner's Initials |      |
| Question            | Mark |
| 1                   |      |
| 2                   |      |
| 3                   |      |
| 4                   |      |
| 5                   |      |
| 6                   |      |
| 7                   |      |
| 8                   |      |
| TOTAL               |      |



General Certificate of Secondary Education  
Foundation Tier  
June 2011

# Physics

# PHY3F

# F

Unit Physics P3

Written Paper

Friday 27 May 2011 9.00 am to 9.45 am

**For this paper you must have:**

- a ruler.
- You may use a calculator.

### Time allowed

- 45 minutes

### Instructions

- Use black ink or black ball-point pen.
- Fill in the boxes at the top of this page.
- Answer **all** questions.
- You must answer the questions in the spaces provided. Do not write outside the box around each page or on blank pages.
- Do all rough work in this book. Cross through any work you do not want to be marked.

### Information

- The marks for questions are shown in brackets.
- The maximum mark for this paper is 45.
- You are expected to use a calculator where appropriate.
- You are reminded of the need for good English and clear presentation in your answers.

### Advice

- In all calculations, show clearly how you work out your answer.



J U N 1 1 P H Y 3 F 0 1

**There are no questions printed on this page**

**DO NOT WRITE ON THIS PAGE  
ANSWER IN THE SPACES PROVIDED**



Answer **all** questions in the spaces provided.

**1** The diagram shows part of the lifecycle of a very large star.

Use words or phrases from the box to complete the sentences contained in the diagram.

**black hole**

**red supergiant**

**supernova**

**white dwarf**

(3 marks)

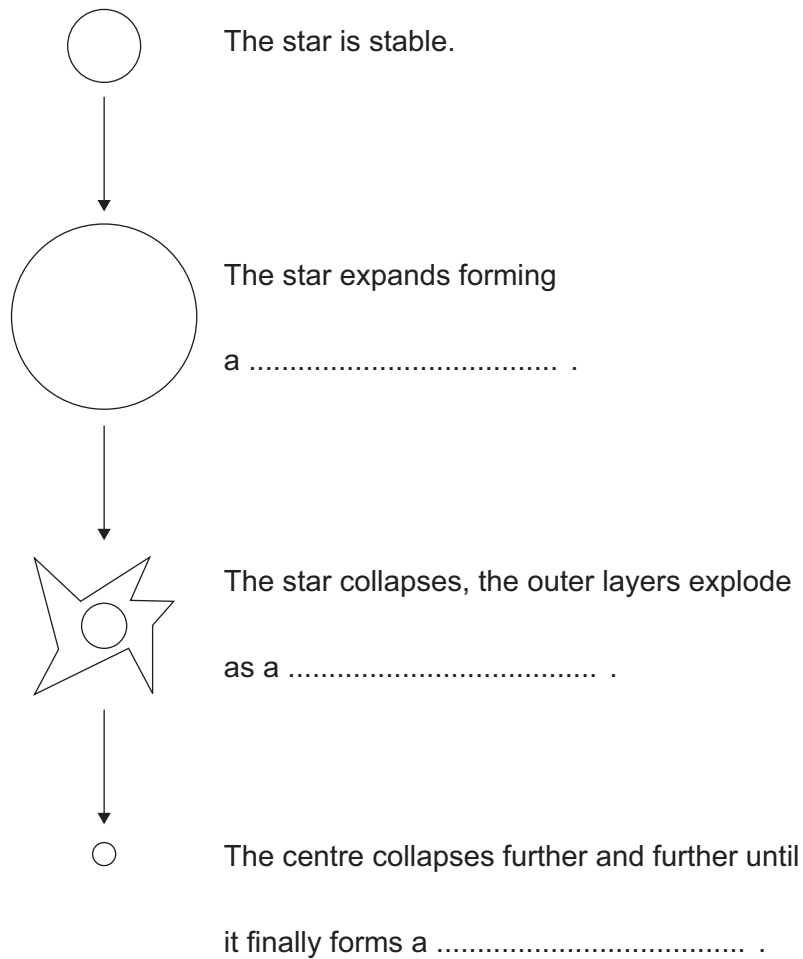

**Turn over for the next question**

3

**Turn over ►**



2 The centre of mass of an object is where the mass of the object may be thought to be concentrated.

2 (a) Use a word or phrase from the box to complete the sentence below.

|       |       |                |
|-------|-------|----------------|
| above | below | to the side of |
|-------|-------|----------------|

A hanging object will come to rest with its centre of mass directly

..... the point from which it hangs.  
(1 mark)

2 (b) The diagram shows the equipment that a student uses to find the centre of mass of a sheet of cardboard. She intends to draw two lines on the sheet. The centre of mass of the sheet will be where these lines cross.

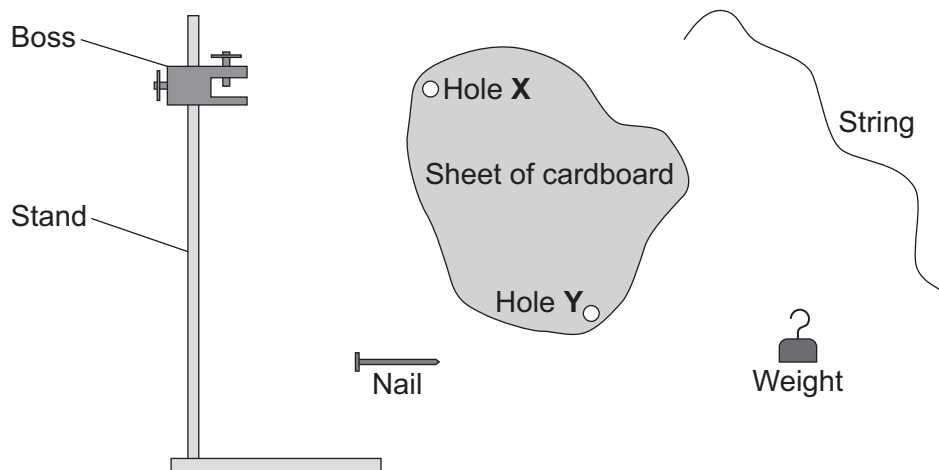

Use words from the box to complete the sentences below.

|      |           |      |       |        |        |
|------|-----------|------|-------|--------|--------|
| boss | cardboard | nail | stand | string | weight |
|------|-----------|------|-------|--------|--------|

The nail is put through hole **X** in the cardboard sheet. The nail is held in the  
..... . The string is tied to the weight and then the other  
end of the string is hung from the ..... . A line is drawn on  
the cardboard sheet to mark the position of the ..... . This is repeated  
using hole **Y**.

(3 marks)



**2 (c)** The diagram below shows a plastic rectangle.

**2 (c) (i)** Use a ruler to draw an axis of symmetry on the rectangle.

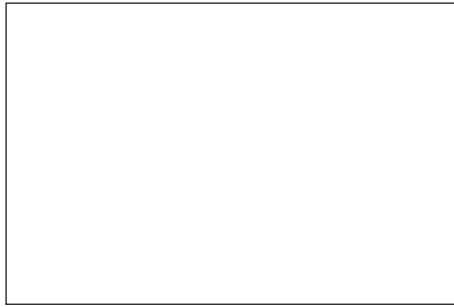

(1 mark)

**2 (c) (ii)** Draw an **X** on the diagram so that the centre of the **X** marks the centre of mass of the rectangle.

(1 mark)



**Turn over for the next question**

**Turn over ►**



**3** Ultrasound waves are very high frequency sound waves. They cannot be heard by humans.

**3 (a)** Ultrasound waves can be used to clean jewellery.

The jewellery is put into a container of cleaning fluid.

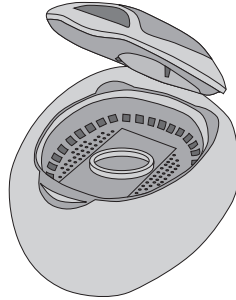

Complete each sentence to explain how ultrasound can clean jewellery.

The ultrasound generator makes the molecules of the cleaning fluid

..... . The molecules knock particles of .....

from the surface of the jewellery.

(2 marks)

**3 (b)** Give a medical use for ultrasound.

.....

(1 mark)



- 3 (c)** Ultrasound waves can be represented on the screen of a cathode ray oscilloscope (CRO).

The diagrams show three ultrasound waves.

Each wave is represented on an identical CRO screen, **A**, **B** and **C**.

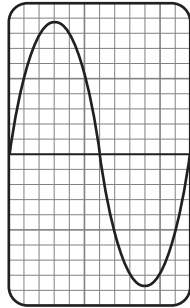

Screen **A**

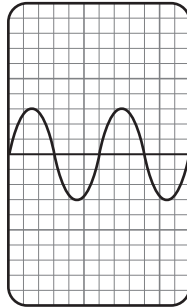

Screen **B**

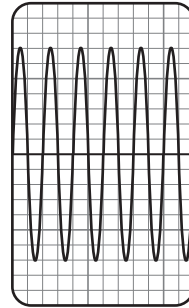

Screen **C**

- 3 (c) (i)** How many complete waves are shown on screen **B**? .....  
(1 mark)

- 3 (c) (ii)** Which screen shows the waves with the highest frequency?

Screen .....

(1 mark)

|   |
|---|
| 5 |
|---|

**Turn over for the next question**

**Turn over ►**



- 4 The satellite shown in the picture is in a geostationary orbit around the Earth.

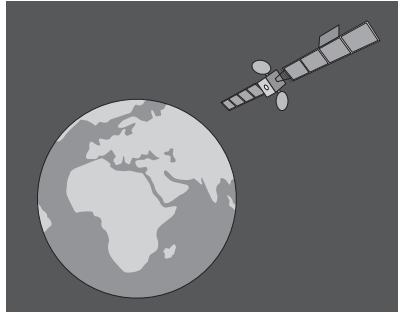

- 4 (a) What is the time period of a geostationary orbit?

Draw a ring around your answer.

**12 hours**

**24 hours**

**1 year**

(1 mark)

- 4 (b) This satellite is in orbit above the Earth's equator.

Put a tick (✓) in the box which explains why the satellite seems to remain above one place on the Earth's equator.

The satellite and the Earth both orbit the Sun at the same rate.

The satellite is attracted by the Earth's gravitational force.

The satellite orbits the Earth at the same rate at which the Earth revolves.

(1 mark)





**4 (c)** A geostationary satellite always seems to be at the same point above the surface of the Earth.

Explain the advantage of this.

.....

.....

.....

.....

(2 marks)

**4 (d)** Give **one** use of a satellite in a geostationary orbit.

.....

.....

(1 mark)

|          |
|----------|
|          |
| <b>5</b> |

**Turn over for the next question**

**Turn over ►**



- 5 (a) A science technician sets up the apparatus shown below to demonstrate the motor effect. He uses a powerful permanent magnet.

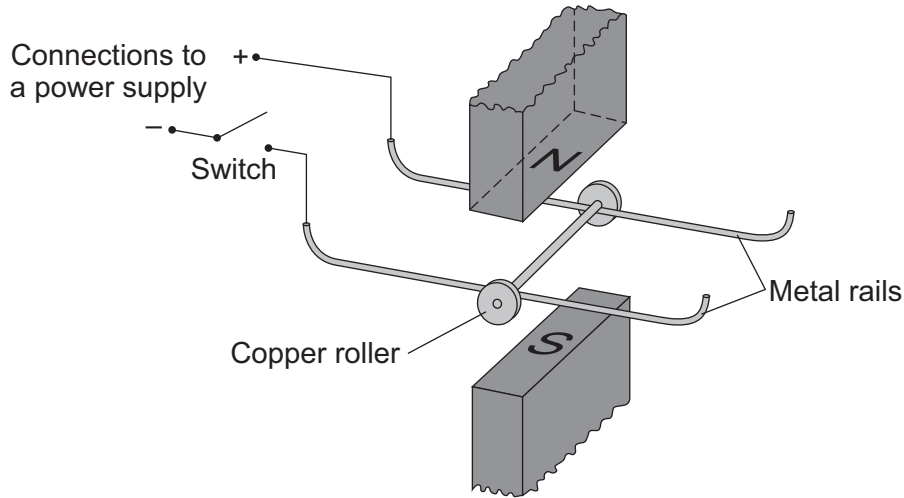

The copper roller is placed across the metal rails. When the switch is closed, the copper roller moves to the right.

- 5 (a) (i) Complete the sentence by drawing a ring around the correct line in the box.

This happens because copper is

- |                          |
|--------------------------|
| an electrical conductor. |
| an electrical insulator. |
| a magnetic material.     |

(1 mark)

- 5 (a) (ii) Suggest **one** change that the technician can make which will cause the copper roller to move faster.

.....

.....

(1 mark)



5 (a) (iii) Suggest **two** changes which the technician can make, each of which will separately cause the copper roller to move to the left.

1 .....

.....

2 .....

.....

(2 marks)

5 (b) Many electrical appliances, such as vacuum cleaners, drills and CD players, contain electric motors. As more electrical appliances are developed, more electricity needs to be generated. Generating electricity often produces pollutant gases.

5 (b) (i) Complete the sentence by drawing a ring around the correct line in the box.

Generating more electricity to power the increasing number of electrical appliances used

|        |   |        |
|--------|---|--------|
|        | an ethical<br>an environmental<br>a political |        |
| raises |   | issue. |

(1 mark)

5 (b) (ii) The number of electrical appliances used in the world's richest countries is increasing yet many people in the world's poorest countries have no access to electricity.

What type of issue does this inequality between people in different countries raise?

.....

(1 mark)

|          |
|----------|
|          |
| <b>6</b> |

**Turn over for the next question**

**Turn over ►**



- 6** At night, it is important that the lights of a car can be seen by other drivers but it is dangerous if these lights dazzle them.

The diagram shows a rear light of a car.

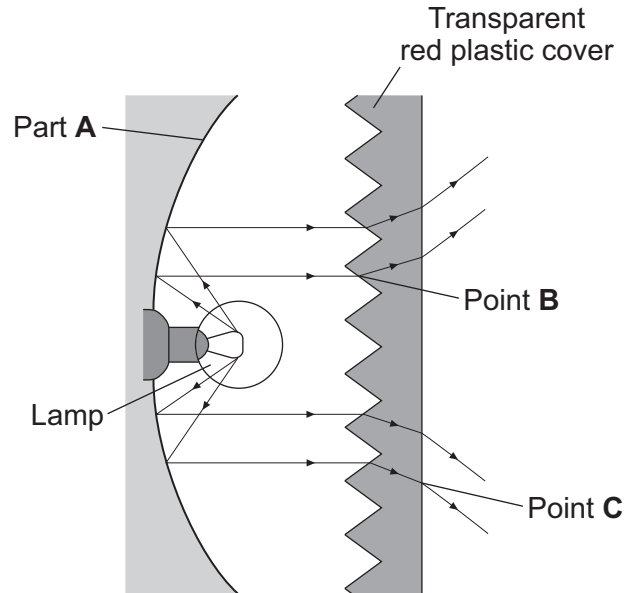

- 6 (a) (i)** Name part **A**.

.....  
(1 mark)

- 6 (a) (ii)** Name the process which occurs at point **B** and at point **C**.

.....  
(1 mark)



6 (b) A headlamp of a car contains a lens.

The ray diagram shows the position and size of the image, I, of an object, O, formed by a lens similar to the one inside a car headlamp.

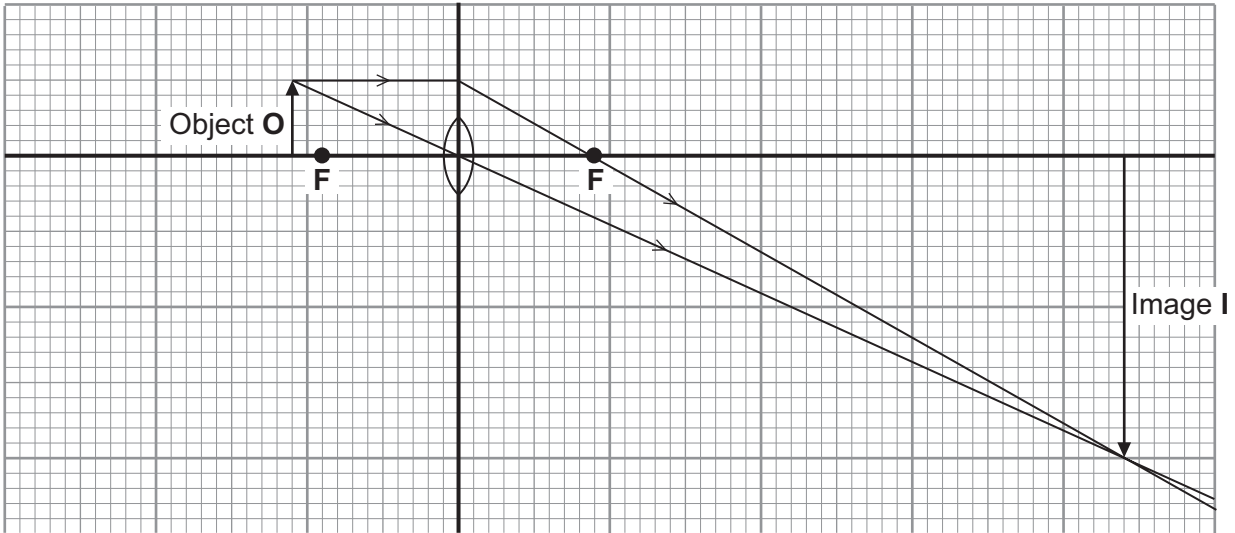

6 (b) (i) What type of lens is shown in the ray diagram?

Draw a ring around your answer.

**converging**

**diverging**

**plane**

(1 mark)

6 (b) (ii) The ray diagram is drawn to scale.

Use the equation in the box to calculate the magnification produced by the lens.

$$\text{magnification} = \frac{\text{image height}}{\text{object height}}$$

Show clearly how you work out your answer.

.....

.....

Magnification = .....  
(2 marks)

|   |
|---|
| 5 |
|---|

Turn over ►



7 A group of students investigates sound waves.  
The diagram shows part of their investigation.

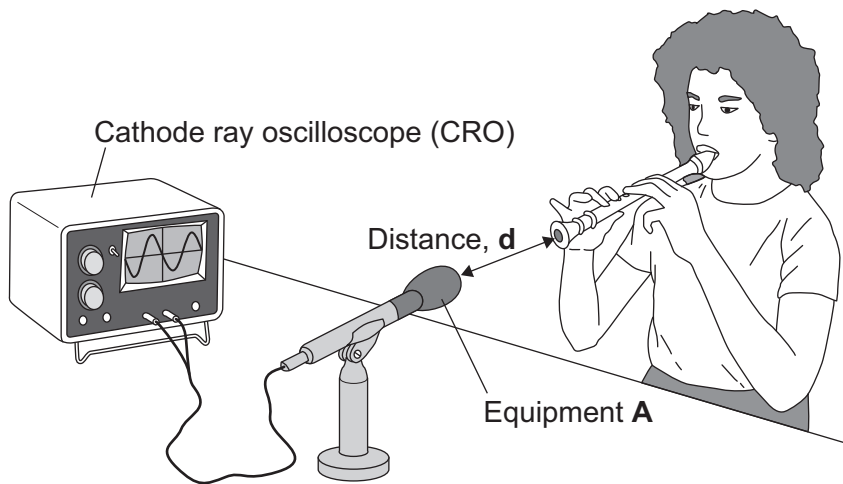

7 (a) Identify the equipment labelled **A**.

.....  
(1 mark)

7 (b) The student plays the same note in the same way at different distances from equipment **A**.

Another student records the amplitude of the wave shown on the cathode ray oscilloscope (CRO).

7 (b) (i) Label this wave to show its amplitude.

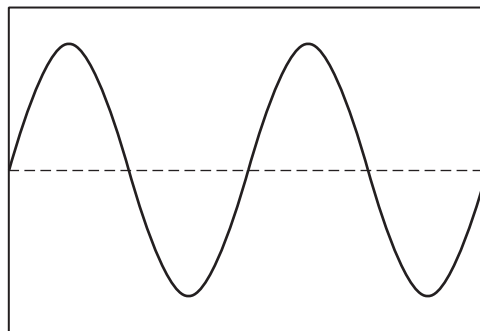

(1 mark)

7 (b) (ii) Complete the sentence.

Increasing the amplitude of a sound wave will increase the .....  
of the sound.

(1 mark)



7 (c) The graph shows the students' average results from several sets of measurements.

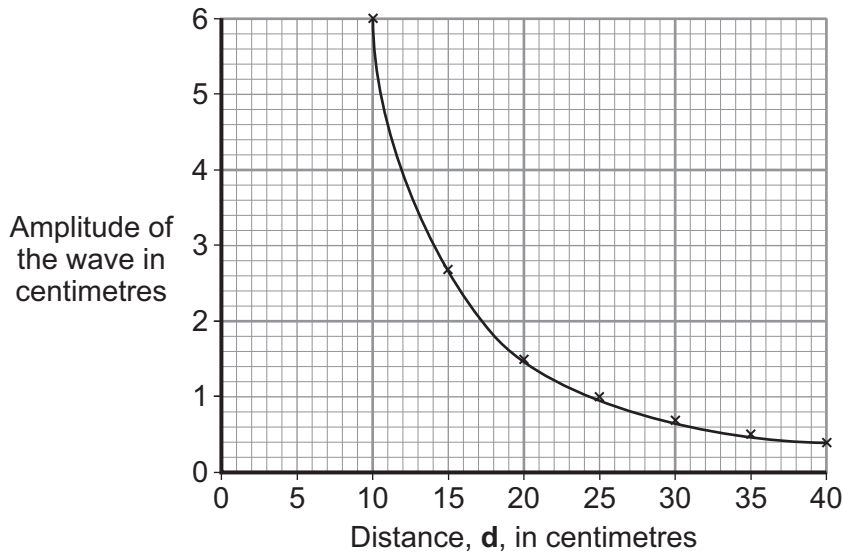

Use the graph to find the distance, *d*, in centimetres, at which the average amplitude is likely to be 2 centimetres.

Distance = ..... cm.  
(1 mark)

7 (d) Write a conclusion for this investigation.

.....  
.....  
(1 mark)

7 (e) A physics teacher uses a signal generator and a loudspeaker to demonstrate the range of hearing of a group of students.

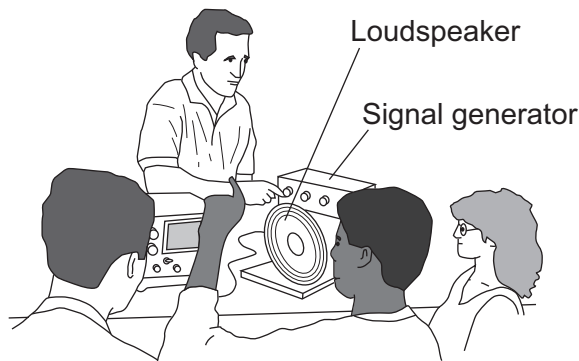

What is the range of frequencies most humans can hear?

Most humans can hear from ..... Hz to ..... Hz.  
(2 marks)

|   |
|---|
| 7 |
|---|

Turn over ►



8 (a) A student investigates the moment of a force.

8 (a) (i) What does the word *moment* mean in this sentence?

.....

.....

(1 mark)

8 (a) (ii) The diagram shows how she sets up her apparatus.

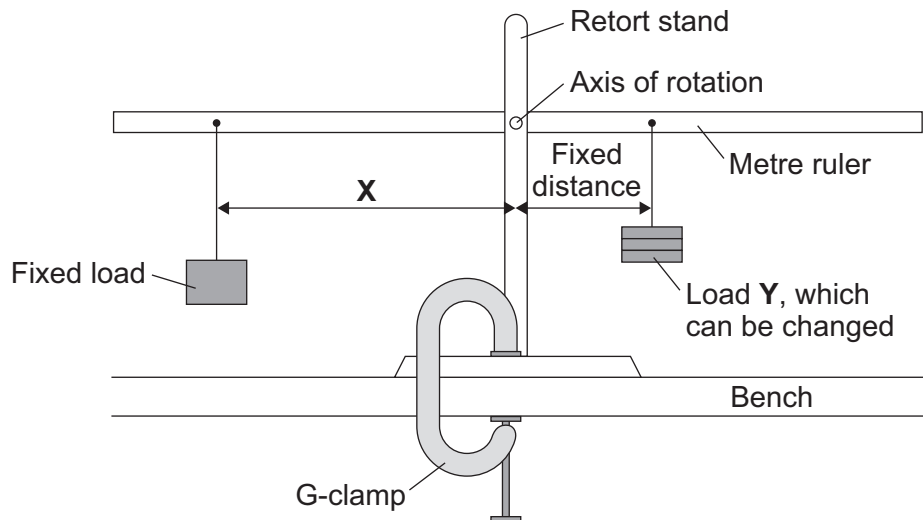

Suggest the purpose of the G-clamp.

.....

.....

(1 mark)





- 8 (a) (iii)** A horizontal rod fits into a hole at the centre of the metre ruler. This is the axis of rotation. The student changes the load **Y** and adjusts the distance **X** until the metre ruler is horizontal. She takes six pairs of measurements which are shown in the table.

| Load <b>Y</b><br>in newtons | Distance <b>X</b><br>in centimetres |
|-----------------------------|-------------------------------------|
| 1                           | 7                                   |
| 2                           | 14                                  |
| 3                           | 21                                  |
| 4                           | 28                                  |
| 5                           | 35                                  |
| 6                           | 42                                  |

Explain fully how distance **X** varies with load **Y**.

.....

.....

.....

.....

.....

(2 marks)

- 8 (a) (iv)** The weight of the ruler can be ignored in this experiment.

Which statement gives the reason why?

Put a tick (✓) in the box next to your answer.

The weight of the ruler is so small it is negligible.

The centre of mass of the ruler is at the axis of rotation.

The ruler is a symmetrical object.

(1 mark)

**Question 8 continues on the next page**

**Turn over ►**



8 (b) In the summer, a town council fits hanging baskets to some of its lamp posts.

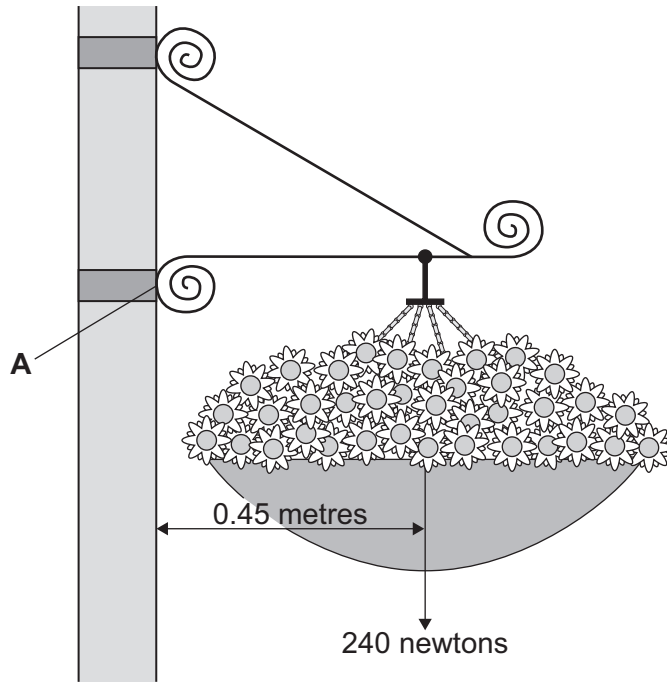

Use the information in the diagram and the equation in the box to calculate the moment produced by the weight of the hanging basket about an axis through point **A**.

|  |
|--|
| $\text{moment} = \text{force} \times \text{perpendicular distance from the line of action of the force to the axis of rotation}$ |
|--|

Show clearly how you work out your answer **and** give the unit.

.....

.....

.....

.....

Moment = .....

(3 marks)

|   |
|---|
| 8 |
|---|

END OF QUESTIONS



**There are no questions printed on this page**

**DO NOT WRITE ON THIS PAGE  
ANSWER IN THE SPACES PROVIDED**



**There are no questions printed on this page**

**DO NOT WRITE ON THIS PAGE  
ANSWER IN THE SPACES PROVIDED**

